

# PARTS CATALOGUE

**VK10Y** (8GS5) CANADA

**VK10Y** (8GS6) EUROPE,RUS,JAPAN

1H8GS-100E1

( )



2016/03/23

NEWS No.	DATE	COMMENT
PE0-SM-080005	Nov.,26,2008	COR:FIG.6 RADIATOR&HOSE LIST/ ILLUSTRATION CORRECTION
PE0-SM-110011	Sep.,13,2011	COR: PRIMARY SHEAVE, ALTERNATE REBUILD KIT ILLUSTRATION CORRECTION
PE0-SM-120001	Jan.,25,2012	COR:FIG.10 CARBURETOR ILLUSTRATION CORRECTION
PE0-SM-130007	Jul.,31,2013	MOD:FIG.31 TRACI DRIVE 2 LIST ILLUSTRATION CORRECTION
PE0-SM-130008	Sep.,10,2013	COR:FIG.28 TRACK SUSPENSION 2 ILLUSTRATION CORRECTION
PE0-SM-160011	Mar.,11,2016	COR:FIG.16 SECONDARY SHEAVE/31 TRACK DRIVE 2 LIST&ILLUST CORRECTION

VK10Y  
PARTS CATALOGUE  
©2008 by Yamaha Motor Co., Ltd.  
1st edition, September 2008  
All rights reserved.  
Any reprinting or unauthorized use  
without the written permission of  
Yamaha Motor Co., Ltd.  
is expressly prohibited.  
Printed in Japan.

# FOREWORD

This Parts Catalogue is related to the parts for the model(s) on the cover page. When you are ordering replacement parts, please refer to this Parts Catalogue and quote both part numbers and part names correctly.

1. Modifications or additions which have been made after the issue of the Parts Catalogue will be announced in the Parts News.

It is advisable that you make the necessary corrections to the Parts Catalogue according to the Parts News.

2. Abbreviations

The following abbreviations are used in this Parts Catalogue.

“UR” Use specified parts number.

“UN” Use as many as needed.

“AP” Alternate Parts

“LM” Locally Made (Parts need to be ordered locally)

“F#” Frame No. (Applicable machine No.)

“O/S” Over Size

3. The number of components for assembly

- Parts, which are to be supplied in an assembly, are listed with a dot (.) in front of the part name as shown below.
- The numeral appearing to the right of each component part indicates the quantity of parts for each assembly unit.

PART NO.	DESCRIPTION	Q'TY	REMARKS
2F5-83310-60	FRONT FLASHER LIGHT ASSY	2	
115-83311-60	.BULB (6V-18W)	1	

4. Applicable colours of graphics are represented in the “REMARKS” as shown below.

PART NO.	DESCRIPTION	Q'TY	REMARKS
2N4-24110-00-X5	FUEL TANK COMP.	2	MXR
3J1-24240-10	.GRAPHIC, FUEL TANK	1	FOR MXR

5. Note that the illustrations for reference in finding parts numbers are not to be used for assembling. When assembling, please use the applicable service manual.

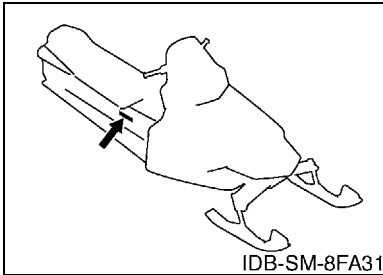
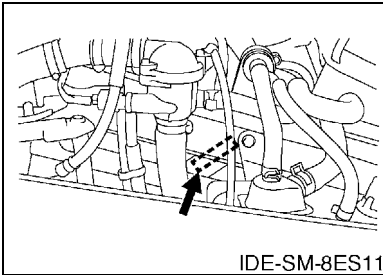
6. The asterisk (\*) before a reference number indicates modified items after the first edition.

# FOREWORD

7. Applicable Serial No.

Engine Serial No.

Frame Serial No.



10. Applicable Starting Serial No.

Frame Serial No.

Serial No.	Name Of Q'ty Column	Model Code
JYE8GS0059A009269	8GS5	8GS5
JYE8GS0059A009269	8GS6	8GS6

8. Applicable Colour Code (The (\*) mark shows Model colour.)

Abbreviation	Colour Name	Colour Code
DBNM8(*)	DARK BLuish GRAY METALLIC 8	0919
DRMK(*)	DEEP RED METALLIC K	0918

9. Quantity Column Information

Column No.	Name Of Q'ty Column	Destination
1	8GS5	CANADA
2	8GS6	EUROPE,RUS,JAPAN

# CONTENTS

## ENGINE

CYLINDER HEAD .....	1
CRANKSHAFT & PISTON .....	2
VALVE .....	4
CAMSHAFT & CHAIN .....	6
WATER PUMP .....	7
RADIATOR & HOSE .....	8
OIL PUMP .....	12
OIL CLEANER .....	13
INTAKE .....	14
CARBURETOR .....	16
EXHAUST .....	19
CRANKCASE .....	21
CRANKCASE COVER 1 .....	22
STARTER .....	23

## DRIVE

PRIMARY SHEAVE .....	24
SECONDARY SHEAVE .....	26

## BODY

ENGINE BRACKET .....	27
OIL TANK .....	28
FRAME .....	29
SKI .....	33
STEERING .....	36
STEERING GATE .....	39
FUEL TANK .....	40
SEAT .....	42
BRAKE .....	43
CONTROL CABLE .....	45
TRACK SUSPENSION 1 .....	46
TRACK SUSPENSION 2 .....	48
TRACK SUSPENSION 3 .....	52
TRACK DRIVE 1 .....	53
TRACK DRIVE 2 .....	54
TRACK DRIVE 3 .....	58
SHROUD .....	59
EMBLEM .....	61
WINDSHIELD .....	62
GUARD & LUGGAGE BOX .....	63
BUMPER .....	65

INSTRUMENT PANEL .....	67
------------------------	----

## ELECTRICAL

GENERATOR .....	68
STARTING MOTOR .....	69
METER .....	70
HEADLIGHT .....	71
TAILLIGHT .....	72
HANDLE SWITCH & LEVER .....	73
ELECTRICAL 1 .....	74
ELECTRICAL 2 .....	75
ELECTRICAL 3 .....	76
ELECTRICAL 4 .....	77
ALTERNATE DRIVE SETTING 1 .....	78
ALTERNATE DRIVE SETTING 2 .....	81
ALTERNATE REBUILD KIT .....	82
ALTERNATE CLUTCH TUNE UP KIT .....	83

## INDEX

NUMERICAL INDEX .....	84
-----------------------	----

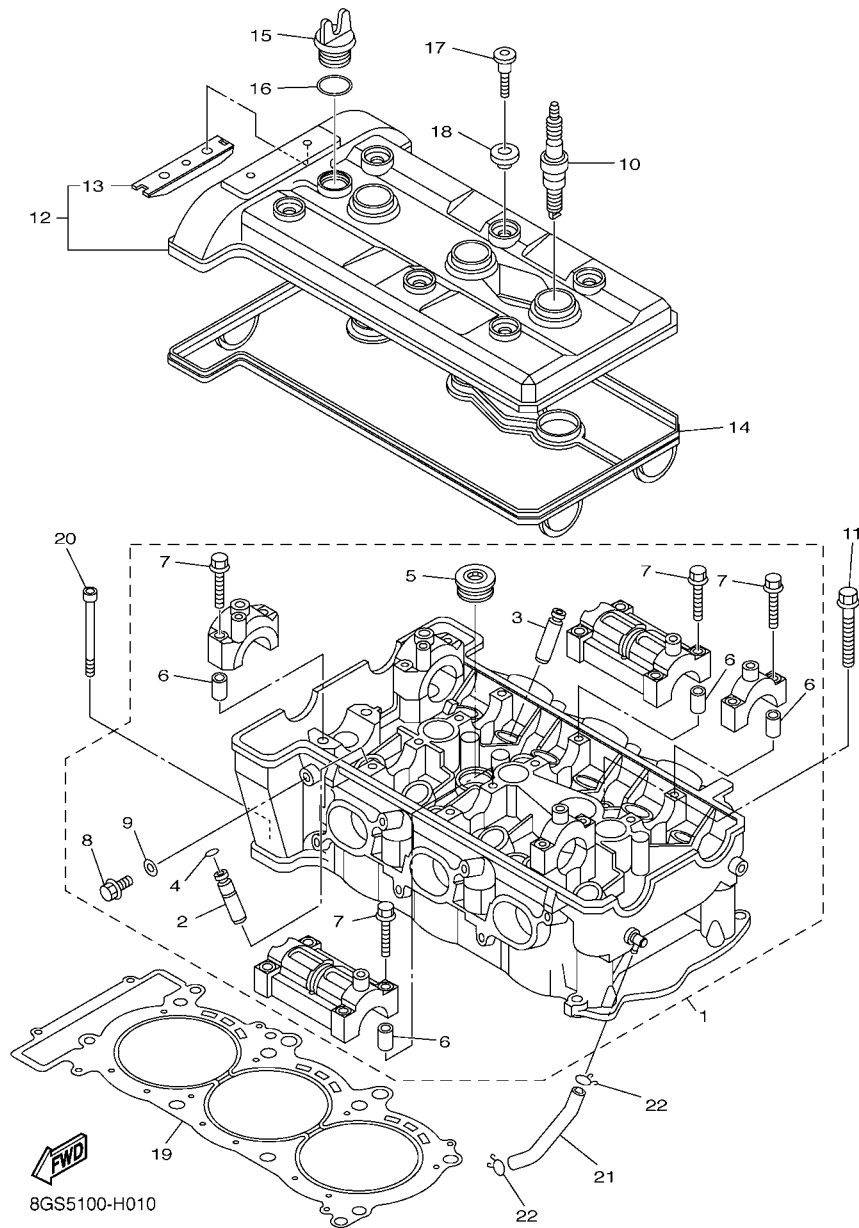
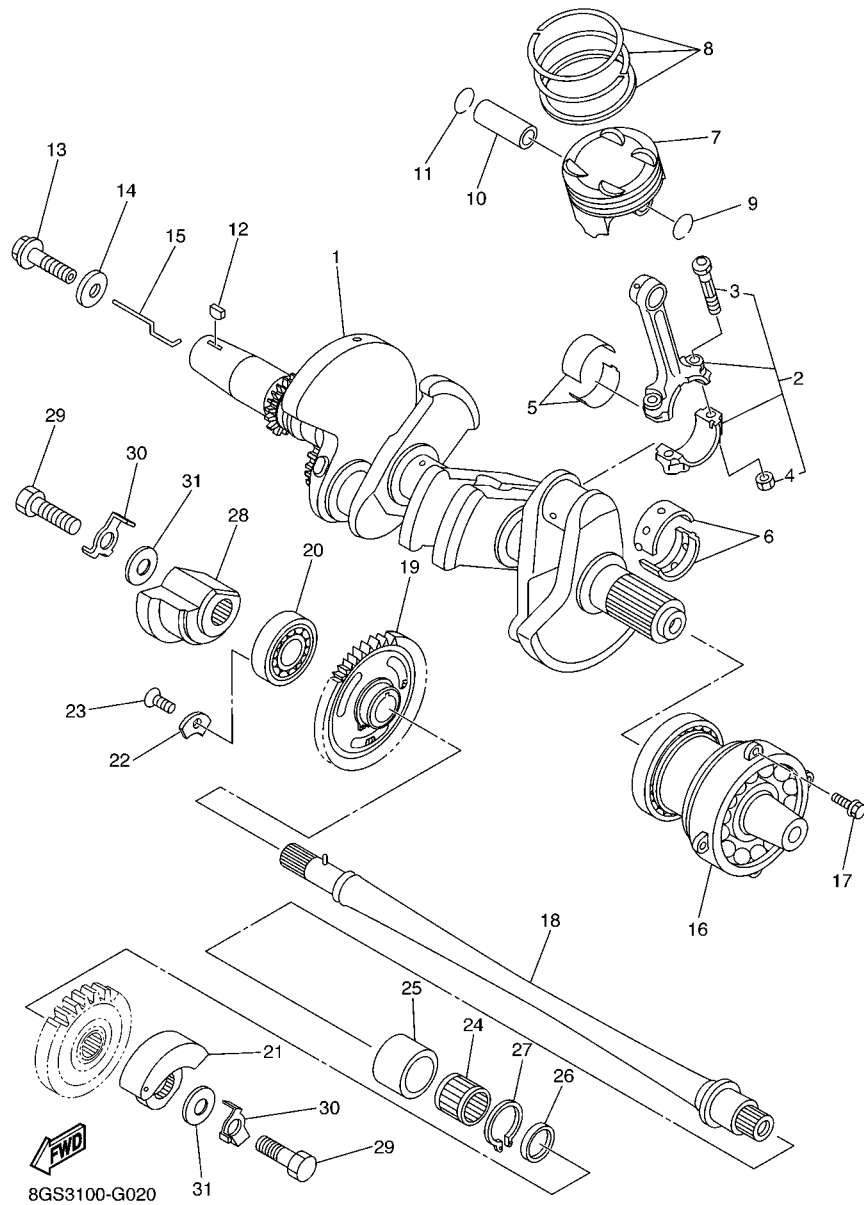


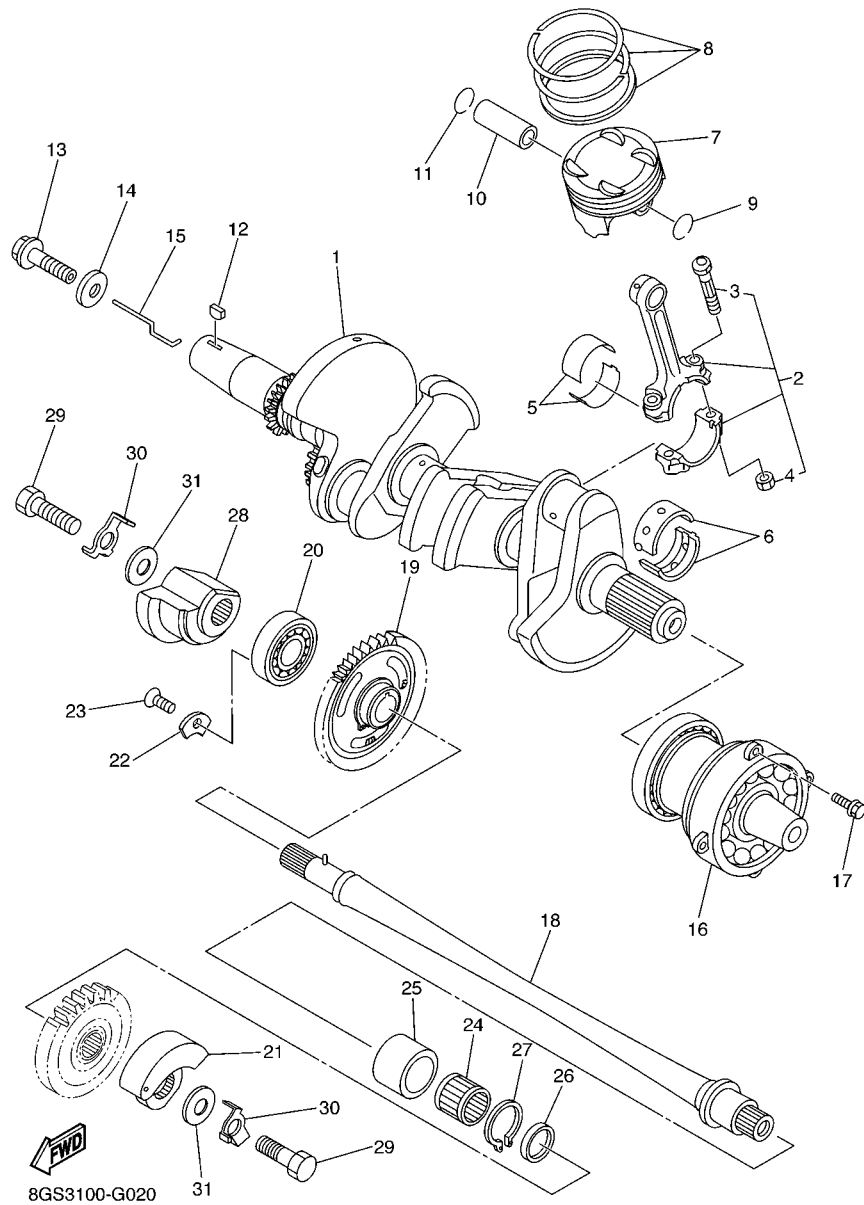
FIG. 1 CYLINDER HEAD

REF. NO.	PART NO.	DESCRIPTION	8GS5	8GS6	REMARKS
1	8ES-11101-02	CYLINDER HEAD ASSY	1	1	
2	5JW-11133-10	.GUIDE, VALVE 1	6	6	
3	3P6-11134-10	.GUIDE, VALVE 2	6	6	
4	93440-09141	.CIRCLIP	6	6	
5	90340-27001	.PLUG, STRAIGHT SCREW	1	1	
6	91808-16023	.PIN, DOWEL	12	12	
7	90105-06026	.BOLT, FLANGE	16	16	
8	95022-08012	.BOLT, FLANGE	1	1	
9	90430-08119	.GASKET	1	1	
10	94701-00411	PLUG, SPARK (NGK R CR8E)	3	3	
	94703-00411	PLUG, SPARK (NGK R CR8E)	3		FOR JPN
11	90119-10004	BOLT, WITH WASHER	8	8	
12	8ES-11191-01	COVER, CYLINDER HEAD 1	1	1	
13	5BE-12241-00	.GUIDE, STOPPER 2	1	1	
14	8ES-11193-00	GASKET, HEAD COVER 1	1	1	
15	3Y1-15363-00	PLUG, OIL	1	1	
16	93210-19123	O-RING	1	1	
17	90109-066F0	BOLT	6	6	
18	4KG-1111G-00	RUBBER, MOUNT 1	6	6	
19	8ES-11181-00	GASKET, CYLINDER HEAD 1	1	1	
20	91312-06065	BOLT	2	2	
21	8ES-13416-00	PIPE, OIL 1	1	1	
22	90467-100A1	CLIP	2	2	



**FIG. 2 CRANKSHAFT & PISTON**

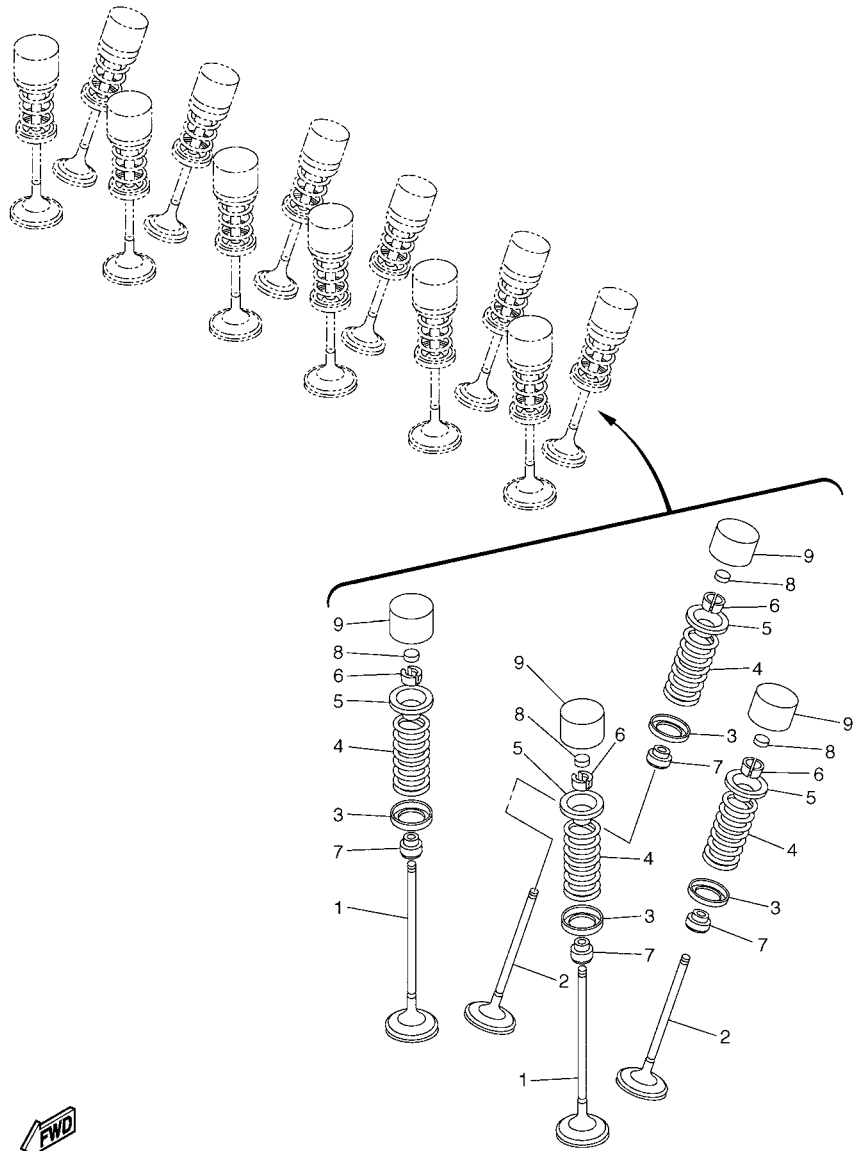
REF. NO.	PART NO.	DESCRIPTION	8GS5	8GS6	REMARKS
1	8ES-11400-02	CRANKSHAFT ASSY	1	1	
2	5JW-11650-01	CONNECTING ROD ASSY	3	3	
3	5JW-11654-00	.BOLT, CONNECTING ROD	2	2	
4	90179-08327	.NUT	2	2	
5	5JW-11656-A0	PLANE BEARING, CONNECTING ROD	6	6	UR WHITE
5JW-11656-00	PLANE BEARING, CONNECTING ROD	6	6	UR BLUE	
5JW-11656-10	PLANE BEARING, CONNECTING ROD	6	6	UR BLACK	
5JW-11656-20	PLANE BEARING, CONNECTING ROD	6	6	UR BROWN	
5JW-11656-30	PLANE BEARING, CONNECTING ROD	6	6	UR GREEN	
5JW-11656-40	PLANE BEARING, CONNECTING ROD	6	6	UR YELLOW	
6	3LD-11416-10	PLANE BEARING, CRANKSHAFT 1	8	8	UR BLACK
3LD-11416-20	PLANE BEARING, CRANKSHAFT 1	8	8	UR BROWN	
3LD-11416-30	PLANE BEARING, CRANKSHAFT 1	8	8	UR GREEN	
3LD-11416-40	PLANE BEARING, CRANKSHAFT 1	8	8	UR YELLOW	
3LD-11416-50	PLANE BEARING, CRANKSHAFT 1	8	8	UR PINK	
3LD-11416-60	PLANE BEARING, CRANKSHAFT 1	8	8	UR RED	
3LD-11416-70	PLANE BEARING, CRANKSHAFT 1	8	8	UR WHITE	
7	8ES-11631-00	PISTON (STD)	3	3	
8	5JW-11603-00	PISTON RING SET (STD)	3	3	
9	93450-19095	CIRCLIP	3	3	
10	5JW-11633-00	PIN, PISTON	3	3	
11	93450-19095	CIRCLIP	3	3	
12	90280-03045	KEY, WOODRUFF	1	1	
13	90105-12032	BOLT, FLANGE	1	1	
14	90201-121H0	WASHER, PLATE	1	1	
15	59J-11455-00	SHAFT 1	1	1	
16	8ES-11406-02	SHAFT ASSY	1	1	



**FIG. 2 CRANKSHAFT & PISTON**

REF. NO.	PART NO.	DESCRIPTION	8GS5	8GS6		REMARKS
17	95812-06020	BOLT, FLANGE	4	4		
18	8ES-11407-02	SHAFT ASSY., 2	1	1		
19	8ES-11530-00	BALANCER WEIGHT GEAR COMP.	1	1		
20	93306-30323	BEARING	1	1		
21	8ES-11454-00	WEIGHT 1	1	1		
22	4JT-15381-01	PLATE, BEARING COVER	1	1		
23	90151-06024	SCREW, COUNTERSUNK	1	1		
24	93310-42239	BEARING	1	1		
25	8ES-11428-01	BEARING 1	1	1		
26	8ES-11478-00	COLLAR	1	1		
27	93450-32152	CIRCLIP	1	1		
28	8ES-11464-00	WEIGHT 2	1	1		
29	97012-10025	BOLT	2	2		
30	90215-10003	WASHER, LOCK	2	2		
31	90201-10591	WASHER, PLATE	2	2		





8ES1100-D030

FIG. 3 VALVE

REF. NO.	PART NO.	DESCRIPTION	8GS5	8GS6		REMARKS
1	5JW-12111-00	VALVE, INTAKE	6	6		
2	5JW-12121-01	VALVE, EXHAUST	6	6		
3	5JW-12116-00	SEAT, VALVE SPRING	12	12		
4	5JW-12113-00	SPRING, VALVE INNER	12	12		
5	5JW-12117-00	RETAINER, VALVE SPRING	12	12		
6	1AA-12118-00	COTTER, VALVE	24	24		
7	3P6-12129-00	SEAL, VALVE STEM	12	12		
8	3LD-12168-00	PAD, ADJUSTING (1.20)	12	12		UR
	3LD-12168-20	PAD, ADJUSTING (1.25)	12	12		UR
	3LD-12168-40	PAD, ADJUSTING (1.30)	12	12		UR
	3LD-12168-60	PAD, ADJUSTING (1.35)	12	12		UR
	3LD-12168-80	PAD, ADJUSTING (1.40)	12	12		UR
	3LD-12168-A0	PAD, ADJUSTING (1.45)	12	12		UR
	3LD-12168-F0	PAD, ADJUSTING (1.50)	12	12		UR
	3LD-12168-H1	PAD, ADJUSTING (1.55)	12	12		UR
	3LD-12168-K1	PAD, ADJUSTING (1.60)	12	12		UR
	3LD-12168-M1	PAD, ADJUSTING (1.65)	12	12		UR
	3LD-12168-R1	PAD, ADJUSTING (1.70)	12	12		UR
	3LD-12168-U1	PAD, ADJUSTING (1.75)	12	12		UR
	3LD-12168-W1	PAD, ADJUSTING (1.80)	12	12		UR
	3LD-12168-Y1	PAD, ADJUSTING (1.85)	12	12		UR
	3LD-12169-11	PAD, ADJUSTING (1.90)	12	12		UR
	3LD-12169-31	PAD, ADJUSTING (1.95)	12	12		UR
	3LD-12169-50	PAD, ADJUSTING (2.00)	12	12		UR
	3LD-12169-70	PAD, ADJUSTING (2.05)	12	12		UR
	3LD-12169-90	PAD, ADJUSTING (2.10)	12	12		UR
	3LD-12169-E0	PAD, ADJUSTING (2.15)	12	12		UR

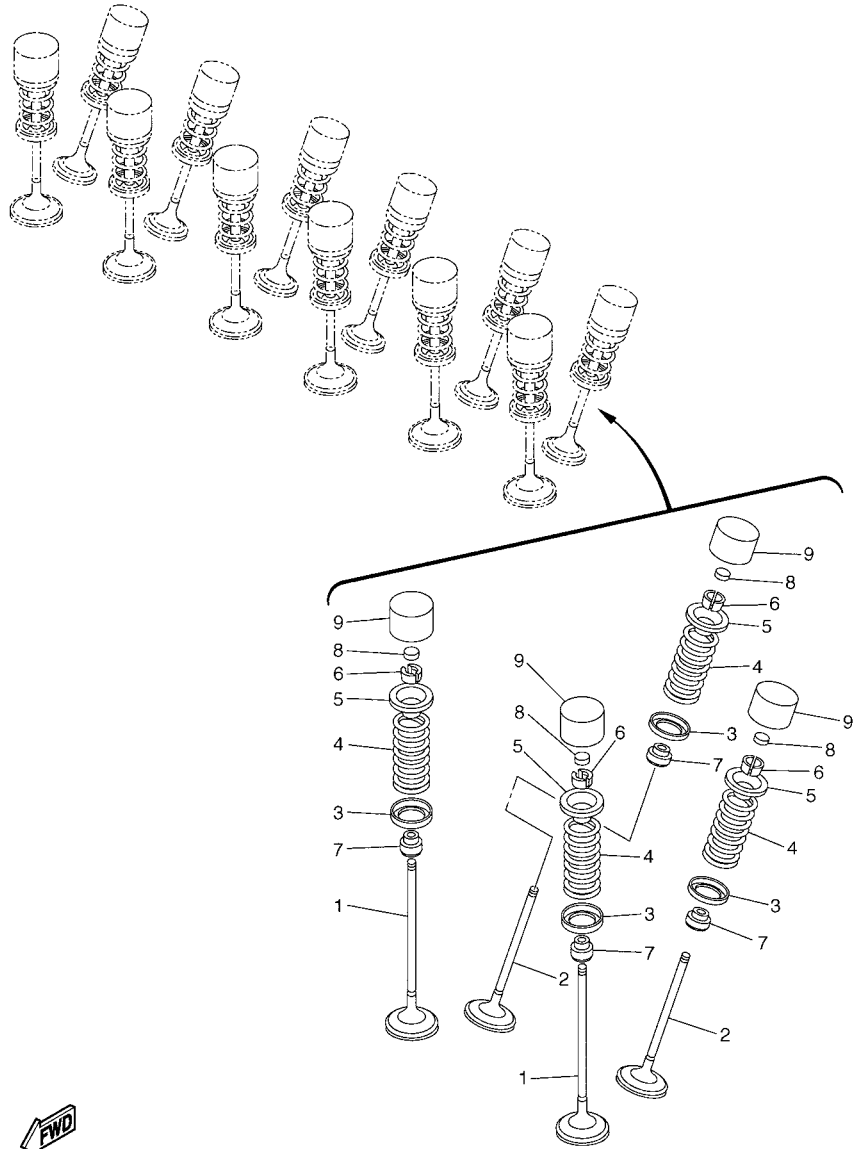
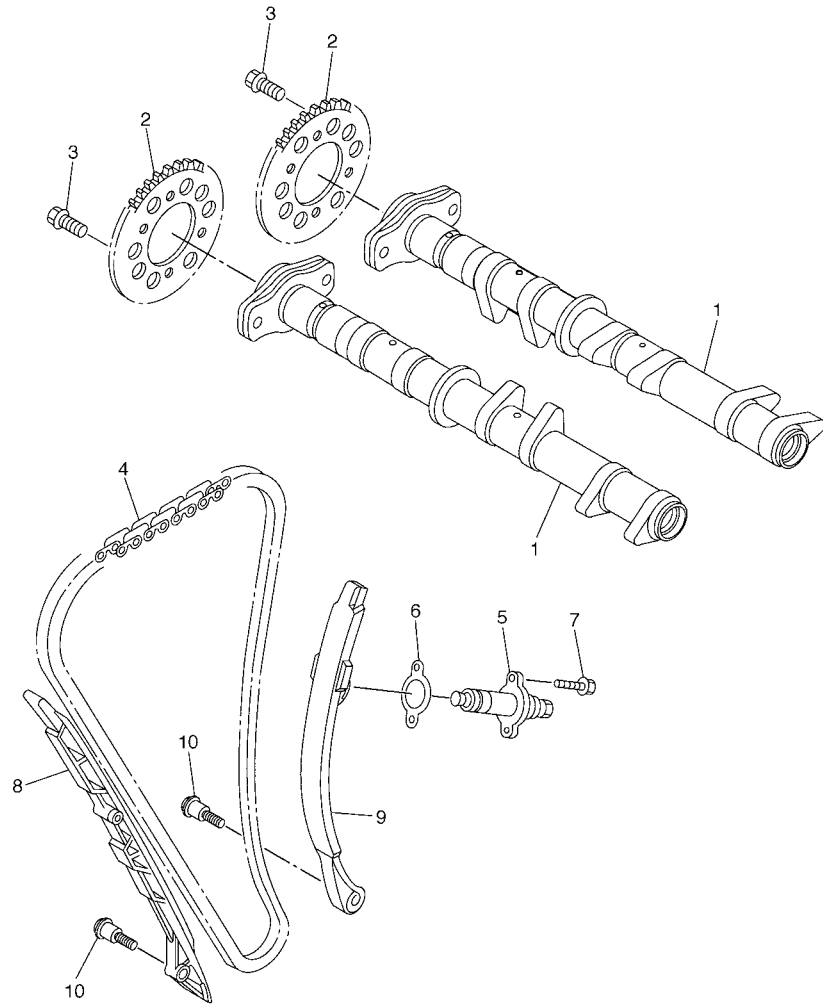


FIG. 3 VALVE

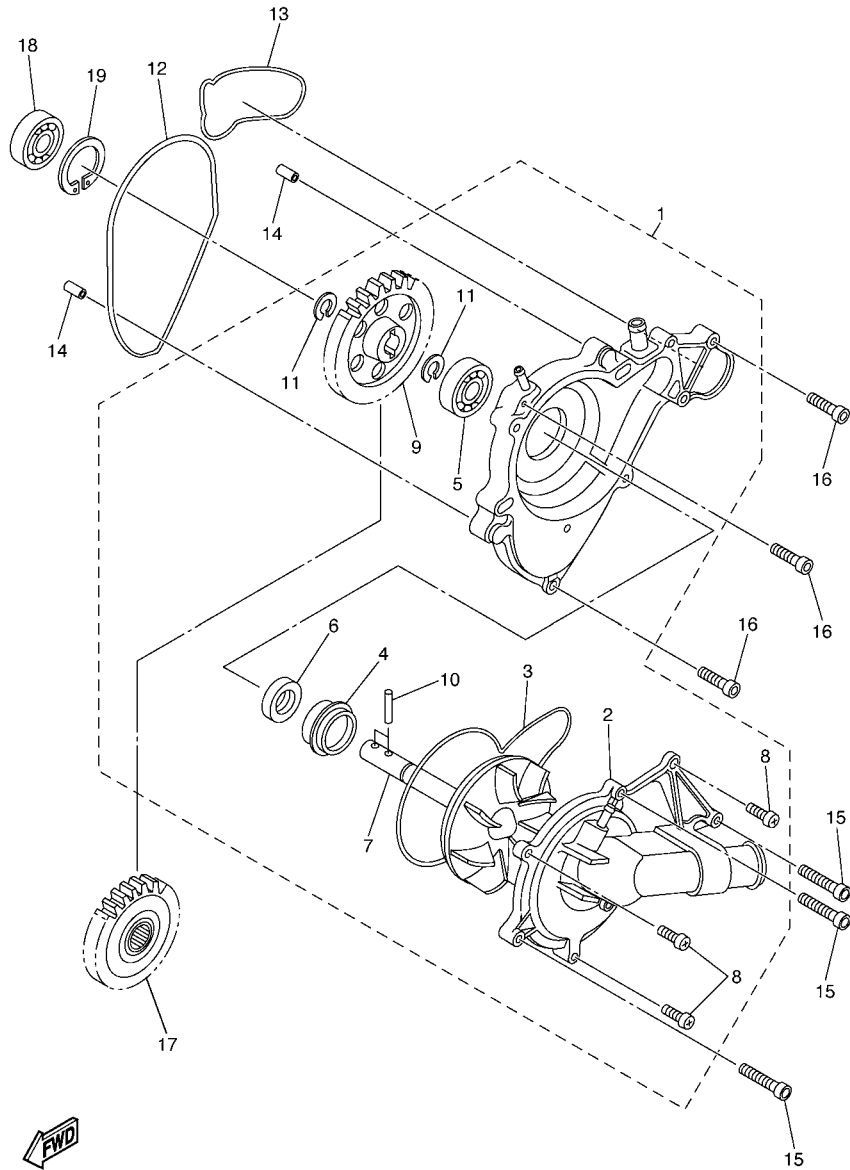
REF. NO.	PART NO.	DESCRIPTION	8CS5	8CS6		REMARKS
8	3LD-12169-G0	PAD, ADJUSTING (2.20)	12	12		UR
	3LD-12169-J0	PAD, ADJUSTING (2.25)	12	12		UR
	3LD-12169-L0	PAD, ADJUSTING (2.30)	12	12		UR
	3LD-12169-N0	PAD, ADJUSTING (2.35)	12	12		UR
	3LD-12169-T0	PAD, ADJUSTING (2.40)	12	12		UR
9	5EB-12153-10	LIFTER, VALVE	12	12		UR YELLOW
	5EB-12153-09	LIFTER, VALVE (O/S)	12	12		UR GREEN



  
 8ES1100-D040

**FIG. 4 CAMSHAFT & CHAIN**

REF. NO.	PART NO.	DESCRIPTION	8GS5	8GS6		REMARKS
1	8ES-12170-01	CAMSHAFT ASSY 1	2	2		
2	8ES-12176-00	SPROCKET, CAM CHAIN	2	2		
3	90105-07004	BOLT, FLANGE	4	4		
4	94591-59140	CHAIN	1	1		
5	8ES-12210-01	TENSIONER ASSY, CAM CHAIN	1	1		
6	4FM-12213-00	GASKET, TENSIONER CASE	1	1		
7	95022-06020	BOLT, FLANGE	2	2		
8	8ES-12251-00	DAMPER, CHAIN 1	1	1		
9	8ES-12252-00	DAMPER, CHAIN 2	1	1		
10	90109-06187	BOLT	2	2		



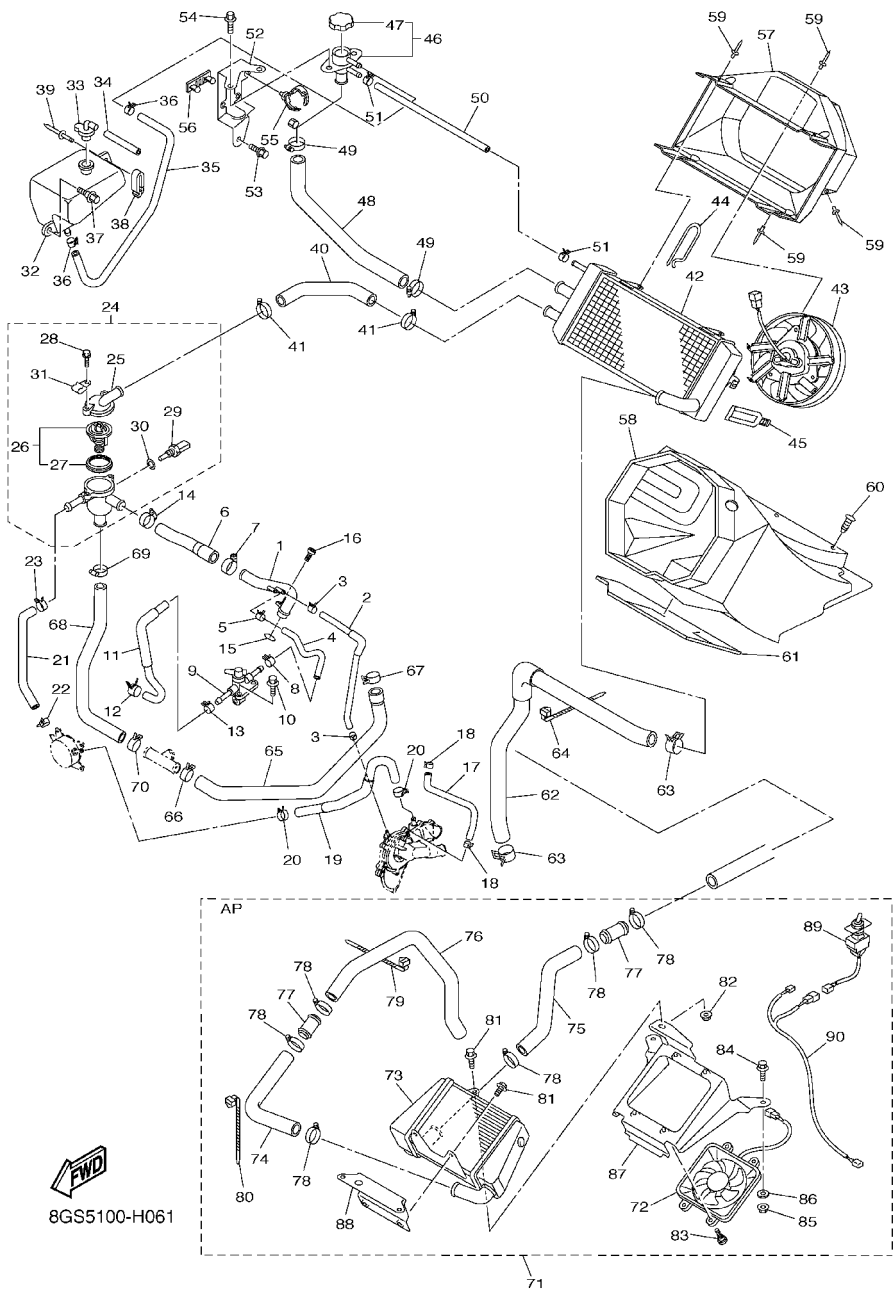
8FJ3100-E050

FIG. 5 WATER PUMP

REF. NO.	PART NO.	DESCRIPTION	8GS5	8GS6	REMARKS
1	8ES-12420-02	WATER PUMP ASSY	1	1	
2	8ES-12422-00	.COVER, HOUSING	1	1	
3	8ES-12427-00	.GASKET, HOUSING COVER 1	1	1	
4	8ES-12438-00	.SEAL, MECHANICAL	1	1	
5	93306-00006	.BEARING	1	1	
6	93102-10207	.OIL SEAL (SD 10-21-5 HS)	1	1	
7	8ES-12450-01	.IMPELLER SHAFT ASSY	1	1	
8	98502-06016	.SCREW, PAN HEAD	3	3	
9	8ES-12459-01	.GEAR, IMPELLER SHAFT	1	1	
10	93604-16092	.PIN, DOWEL	2	2	
11	99002-08600	.CLIP	2	2	
12	8ES-12435-00	GASKET	1	1	
13	8ES-12434-00	GASKET	1	1	
14	99530-08012	PIN, DOWEL	2	2	
15	91312-06040	BOLT	4	4	
16	91312-06025	BOLT	3	3	
17	8ES-12436-00	GEAR, DRIVE	1	1	
18	93306-00006	BEARING	1	1	
19	93420-26077	CIRCLIP	1	1	

FIG. 6 RADIATOR & HOSE

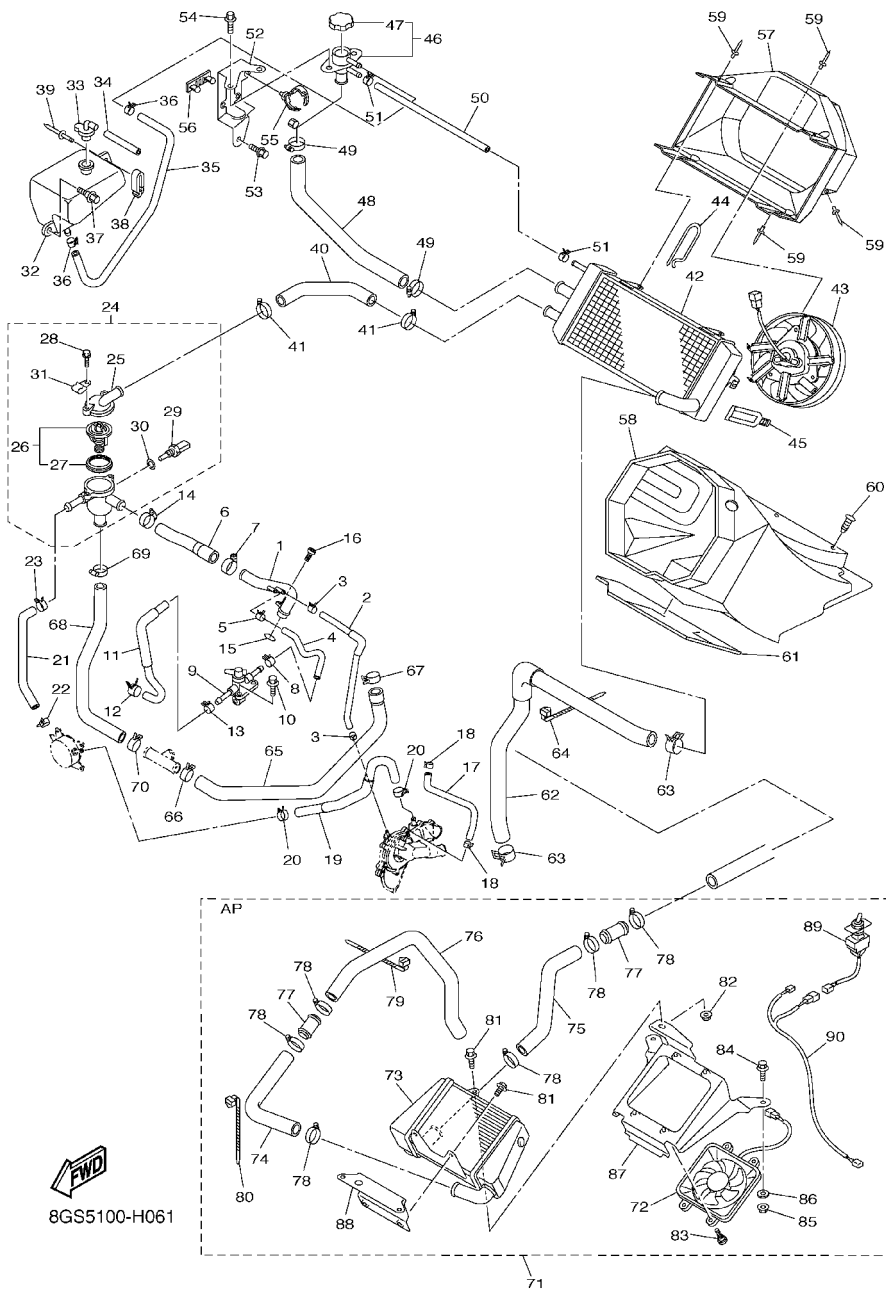
REF. NO.	PART NO.	DESCRIPTION	8GS5	8GS6	REMARKS
1	8ES-12482-00	PIPE 2	1	1	
2	8ES-12485-01	PIPE 5	1	1	
3	90467-110A2	CLIP	2	2	
4	8FN-12577-00	HOSE 2	1	1	
5	90467-110A2	CLIP	1	1	
6	8FN-1243E-00	HOSE 2	1	1	
7	90450-38040	HOSE CLAMP ASSY	1	1	
8	90467-110A2	CLIP	1	1	
9	8FW-1249A-00	COCK ASSY	1	1	
10	95812-06014	BOLT, FLANGE	2	2	
11	8FN-12579-00	HOSE 4	1	1	
12	90467-110A2	CLIP	1	1	
13	90467-110A2	CLIP	1	1	
14	90450-35001	HOSE CLAMP ASSY	1	1	
15	93210-26006	O-RING	1	1	
16	91312-06016	BOLT	1	1	
17	8ES-12578-00	HOSE 3	1	1	
18	90467-110A2	CLIP	2	2	
19	8ES-12588-00	HOSE 5	1	1	
20	90467-17089	CLIP	2	2	
21	8FN-12589-00	HOSE 6	1	1	
22	90467-17089	CLIP	1	1	
23	90467-17089	CLIP	1	1	
24	8FN-12580-00	JOINT ASSY	1	1	
25	5EB-12413-00	.COVER, THERMOSTAT	1	1	
26	8FN-12410-00	.THERMOSTAT ASSY	1	1	
27	8EK-12412-00	..SEAL, THERMOSTAT	1	1	



8GS5100-H061

FIG. 6 RADIATOR & HOSE

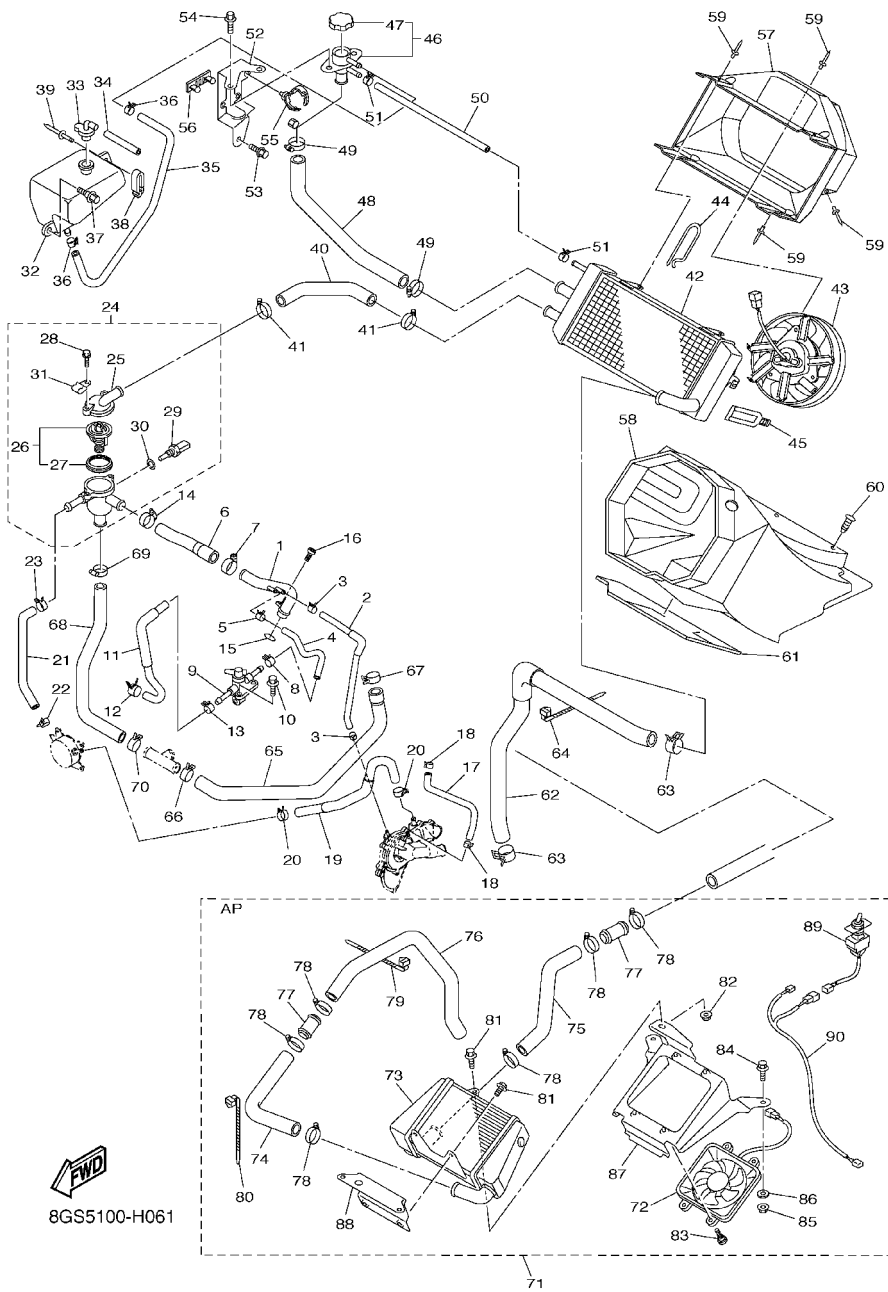
REF. NO.	PART NO.	DESCRIPTION	8GS5	8GS6	REMARKS
28	95022-06020	.BOLT, FLANGE	2	2	
29	8CC-85790-01	.THERMOSENSOR ASSY	1	1	
30	90201-12790	.WASHER, PLATE	1	1	
31	90465-06M28	.CLAMP	1	1	
32	8FN-21871-00	TANK, RECOVERY	1	1	
33	89A-21815-00	CAP	1	1	
34	90445-112E0	HOSE (L70)	1	1	
35	90445-120J8	HOSE (L450)	1	1	
36	90467-11032	CLIP	2	2	
37	90149-06148	SCREW	2	2	
38	90465-10048	CLAMP	1	1	
39	90267-48182	RIVET, BLIND (4.8X23)	1	1	
40	8FN-1244G-00	HOSE, 4	1	1	
41	90450-35001	HOSE CLAMP ASSY	2	2	
42	8FN-12460-00	RADIATOR ASSY	1	1	
43	8FN-12405-01	BLOWER ASSY	1	1	
44	8CR-77384-01	PIN	1	1	
45	8FA-2389E-00	LATCH	1	1	
46	8FN-12590-00	CONDUCTION ASSY	1	1	
47	3XP-12462-00	.CAP, RADIATOR	1	1	
48	8FN-1244H-00	HOSE 5	1	1	
49	90450-28014	HOSE CLAMP ASSY	2	2	
50	90445-120J6	HOSE (L250)	1	1	
51	90467-11032	CLIP	2	2	
52	8FN-1244E-00	BRACKET 1	1	1	
53	95822-06012	BOLT, FLANGE	2	2	
54	95812-06016	BOLT, FLANGE	2	2	



8GS5100-H061

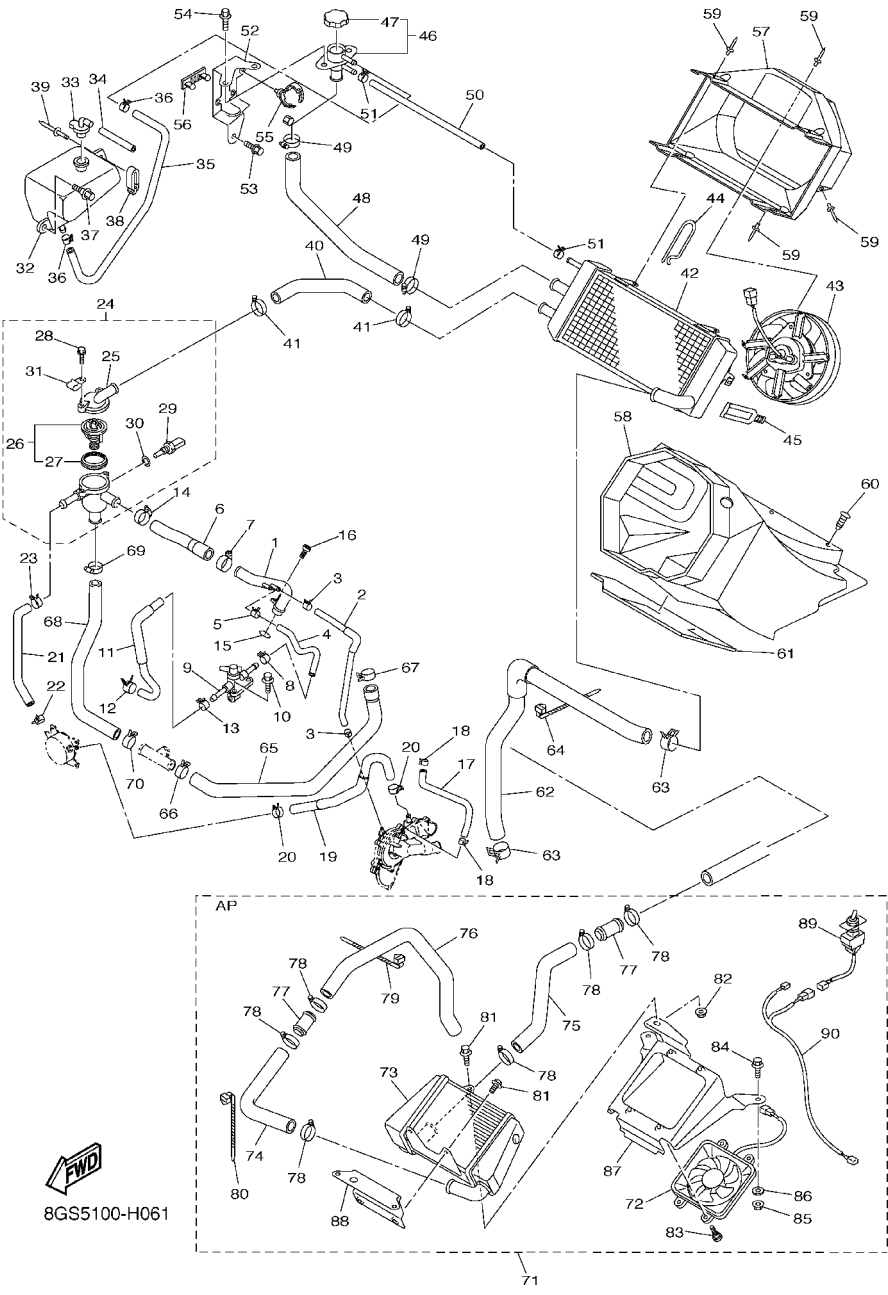
FIG. 6 RADIATOR & HOSE

REF. NO.	PART NO.	DESCRIPTION	8GS5	8GS6	REMARKS
55	90464-20181	CLAMP	1	1	
56	8FA-83614-00	BRACKET	1	1	
57	8FN-12467-00	COVER, RADIATOR	1	1	
58	8FN-21851-00	DUCT, COOLER	1	1	
59	90267-48018	RIVET, BLIND (4.8X18.6 BLACK)	7	7	
60	90269-05055	RIVET	6	6	
61	8FN-77261-00	LINING, SHROUD 1	1	1	
62	8FN-12477-02	PIPE 7	1	1	
63	90467-28144	CLIP	2	2	
64	90460-15126	CLAMP, HOSE	1	1	
65	8FN-1248A-00	PIPE 8	1	1	
66	90467-28046	CLIP	1	1	
67	90467-310A0	CLIP	1	1	
68	8FN-1248E-00	PIPE 9	1	1	
69	90450-35001	HOSE CLAMP ASSY	1	1	
70	90467-28144	CLIP	1	1	
71	8GS-W1246-00	VK10 SUB RADIATOR KIT	1	1	AP
72	8FP-12405-00	.BLOWER ASSY	1	1	AP
73	8GS-12461-00	.RADIATOR ASSY	1	1	AP
74	8FN-1244J-00	.HOSE 6	1	1	AP
75	8FN-1243A-00	.HOSE 1	1	1	AP
76	8FN-1243F-00	.HOSE,3	1	1	AP
77	8FN-12469-00	.JOINT 1	2	2	AP
78	90450-35001	.HOSE CLAMP ASSY	6	6	AP
79	90464-15195	.CLAMP	1	1	AP
80	90460-15126	.CLAMP, HOSE	1	1	AP
81	95822-06012	.BOLT, FLANGE	3	3	AP
82	95702-06500	.NUT, FLANGE	1	1	AP

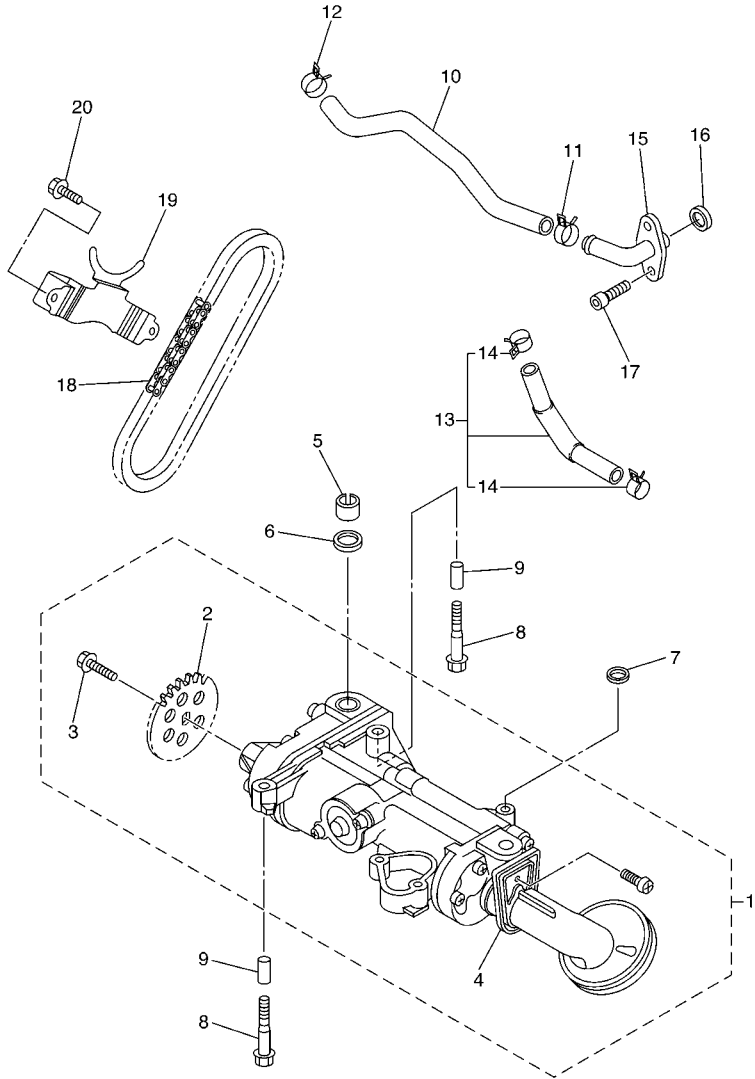


**FIG. 6 RADIATOR & HOSE**

REF. NO.	PART NO.	DESCRIPTION	8GS5	8GS6		REMARKS
83	90149-05129	.SCREW	4	4		AP
84	95822-08016	.BOLT, FLANGE	2	2		AP
85	95702-08500	.NUT, WITH WASHER	2	2		AP
86	90201-08784	.WASHER, PLATE	2	2		AP
87	8FN-1244F-00	.BRACKET 2	1	1		AP
88	8FN-12464-00	.STAY, RADIATOR	1	1		AP
89	8CN-82917-01	.SWITCH	1	1		AP
90	8FN-82509-00	.WIRE, SUB LEAD	1	1		AP







8GS3100-G070

FIG. 7 OIL PUMP

REF. NO.	PART NO.	DESCRIPTION	8GS5	8GS6		REMARKS
1	8ES-13300-00	OIL PUMP ASSY	1	1		
2	4XV-13355-00	.SPROCKET, DRIVEN	1	1		
3	90105-06066	.BOLT, FLANGE	1	1		
4	8ES-13427-00	.SPACER, STRAINER	1	1		
5	8ES-13284-00	PIPE	1	1		
6	93210-18322	O-RING	1	1		
7	93210-14579	O-RING	1	1		
8	95812-06040	BOLT, FLANGE	5	5		
9	91808-22019	PIN, DOWEL	2	2		
10	8FN-13464-00	HOSE, OIL 1	1	1		
11	90467-22097	CLIP	1	1		
12	90467-22097	CLIP	1	1		
13	8FN-1319B-02	HOSE SUB-ASSY., 2	1	1		
14	90467-22097	.CLIP	2	2		
15	8ES-13115-00	CONNECTOR, SUCTION PIPE	1	1		
16	93210-16629	O-RING	1	1		
17	91312-06016	BOLT	2	2		
18	94580-25064	CHAIN	1	1		
19	8ES-13898-00	HOLDER	1	1		
20	95812-06012	BOLT, FLANGE	2	2		

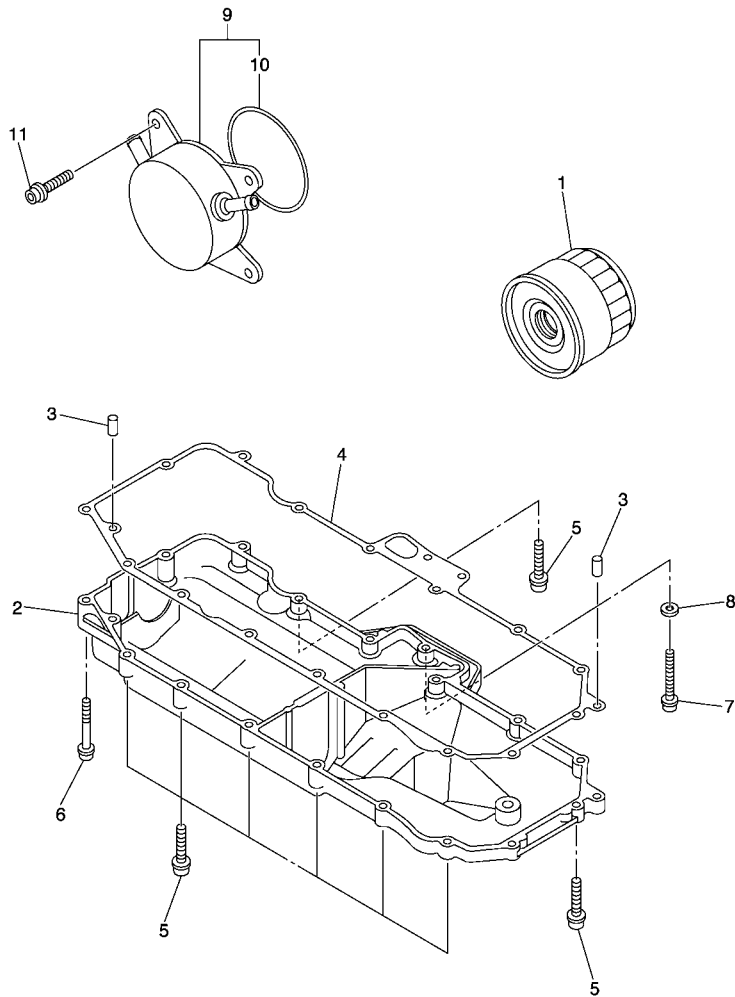
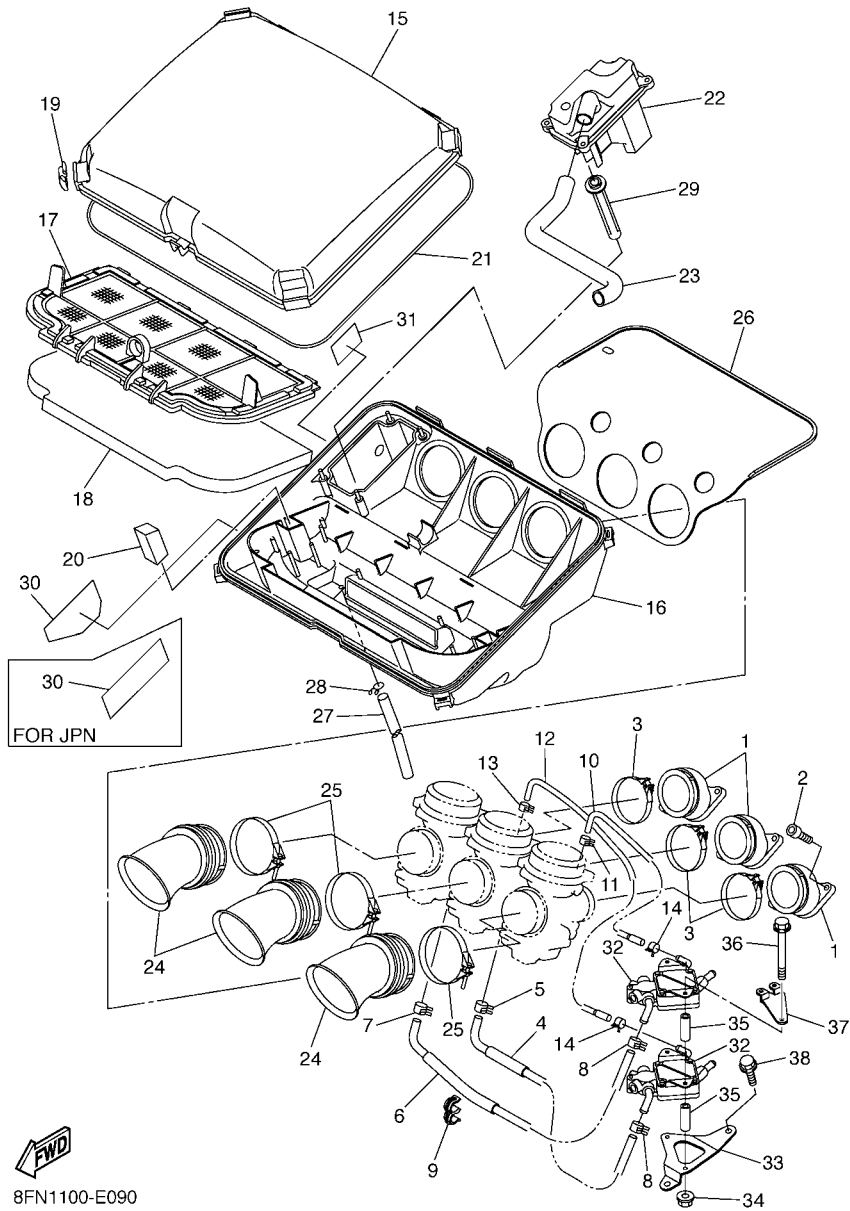


FIG. 8 OIL CLEANER

REF. NO.	PART NO.	DESCRIPTION	8GS5	8GS6			REMARKS
1	5DM-13440-00	ELEMENT ASSY, OIL CLEANER	1	1			
2	8ES-13417-00	COVER, STRAINER	1	1			
3	99530-08012	PIN, DOWEL	2	2			
4	8ES-13414-01	GASKET, STRAINER COVER	1	1			
5	90109-06015	BOLT	15	15			
6	90109-06081	BOLT	2	2			
7	90109-06031	BOLT	1	1			
8	90430-06192	GASKET	1	1			
9	8ES-13470-01	OIL COOLER ASSY	1	1			
10	5JW-13473-00	.O-RING	1	1			
11	90110-06164	BOLT, HEXAGON SOCKET HEAD	4	4			

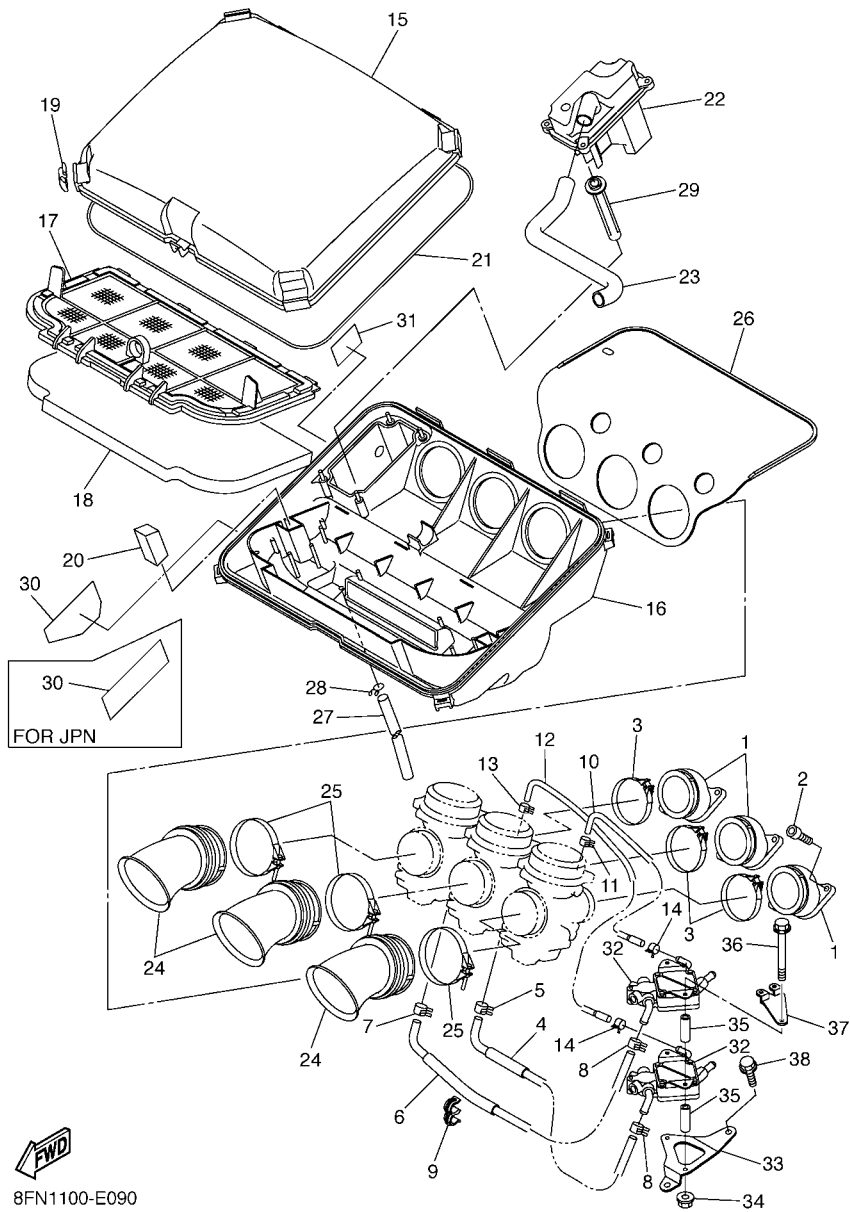
  
8GF3100-F080



8FN1100-E090

FIG. 9 INTAKE

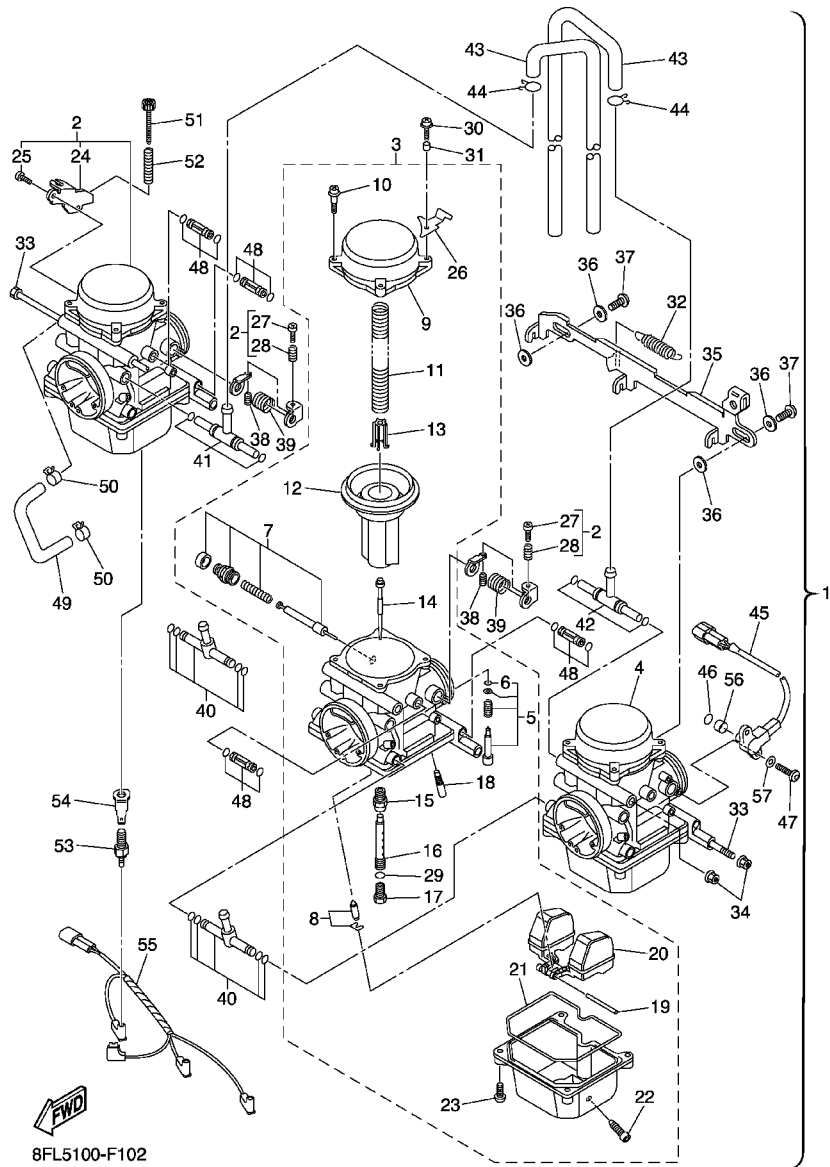
REF. NO.	PART NO.	DESCRIPTION	8GS5	8GS6	REMARKS
1	8ES-13586-10	JOINT, CARBURETOR 1	3	3	
2	91312-06020	BOLT	6	6	
3	90450-57016	HOSE CLAMP ASSY	3	3	
4	8ES-14294-10	HOSE	1		
	8ES-14294-00	HOSE		1	
5	90467-11028	CLIP	1	1	
6	8ES-14298-10	PIPE	1		
	8ES-14298-00	PIPE		1	
7	90467-11028	CLIP	1	1	
8	90467-11028	CLIP	2	2	
9	90464-13194	CLAMP	1	1	
10	8ES-13895-00	HOSE, AIR	1	1	
11	90467-08092	CLIP	1	1	
12	8ES-13892-00	HOSE, AIR 2	1	1	
13	90467-08092	CLIP	1	1	
14	90467-09026	CLIP	2	2	
15	8ES-14431-00	SILENCER, INTAKE 1	1	1	
16	8ES-14441-00	SILENCER, INTAKE 2	1	1	
17	8FN-14472-00	PLATE, ELEMENT	1	1	
18	8ES-14451-00	ELEMENT, AIR CLEANER	1	1	
19	8FA-14436-00	HOOK	4	4	
20	8ES-14425-00	DAMPER 1	2	2	
21	8ES-14452-00	SEAL	1	1	
22	8ES-1441A-00	COVER, CLEANER CASE 1	1	1	
23	8ES-14419-00	PIPE	1	1	
24	8ES-14453-00	JOINT, AIR CLEANER 1	3	3	
25	90450-67001	HOSE CLAMP ASSY	3	3	



8FN1100-E090

FIG. 9 INTAKE

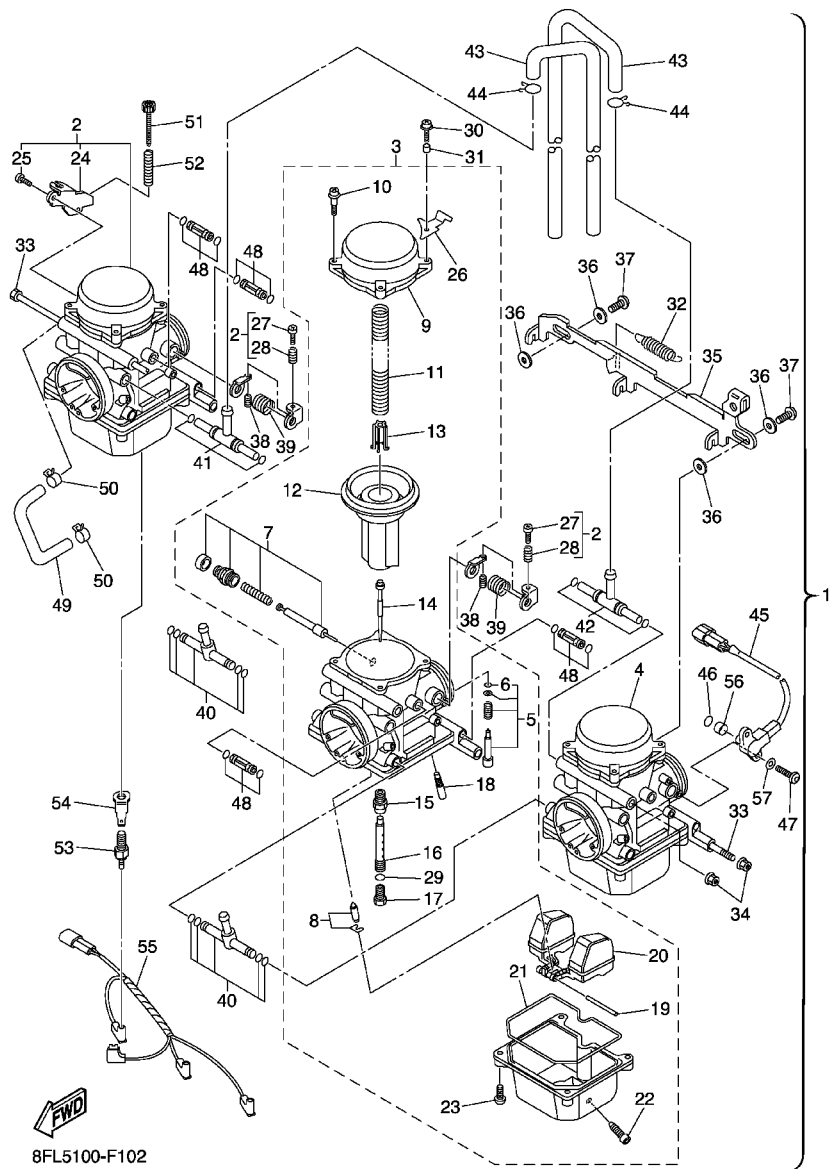
REF. NO.	PART NO.	DESCRIPTION	8GS5	8GS6			REMARKS
26	8ES-14283-00	COVER, CARBURETOR 1	1	1			
27	90445-11M52	HOSE (L150)	1	1			
28	90467-10041	CLIP	1	1			
29	8ES-14148-00	PIPE	1	1			
30	8GS-2815J-E0	LABEL, NOTICE BREATHER PIPE	1				
	8GS-2815J-S0	LABEL, NOTICE BREATHER PIPE		1			FOR EUR, RUS
	8GS-2815J-J0	LABEL, NOTICE BREATHER PIPE		1			FOR JPN
31	8ES-14427-00	LABEL, INSTRUCTION	1	1			
32	8FA-13910-00	FUEL PUMP ASSY	2	2			
33	8FA-24491-00	BRACKET, FUEL PUMP	1	1			
34	95702-06500	NUT, FLANGE	2	2			
35	90387-065V0	COLLAR	4	4			
36	95022-06085	BOLT, FLANGE	2	2			
37	8FN-12443-00	STAY	1	1			
38	95822-06016	BOLT, FLANGE	2	2			



8FL5100-F102

FIG. 10 CARBURETOR

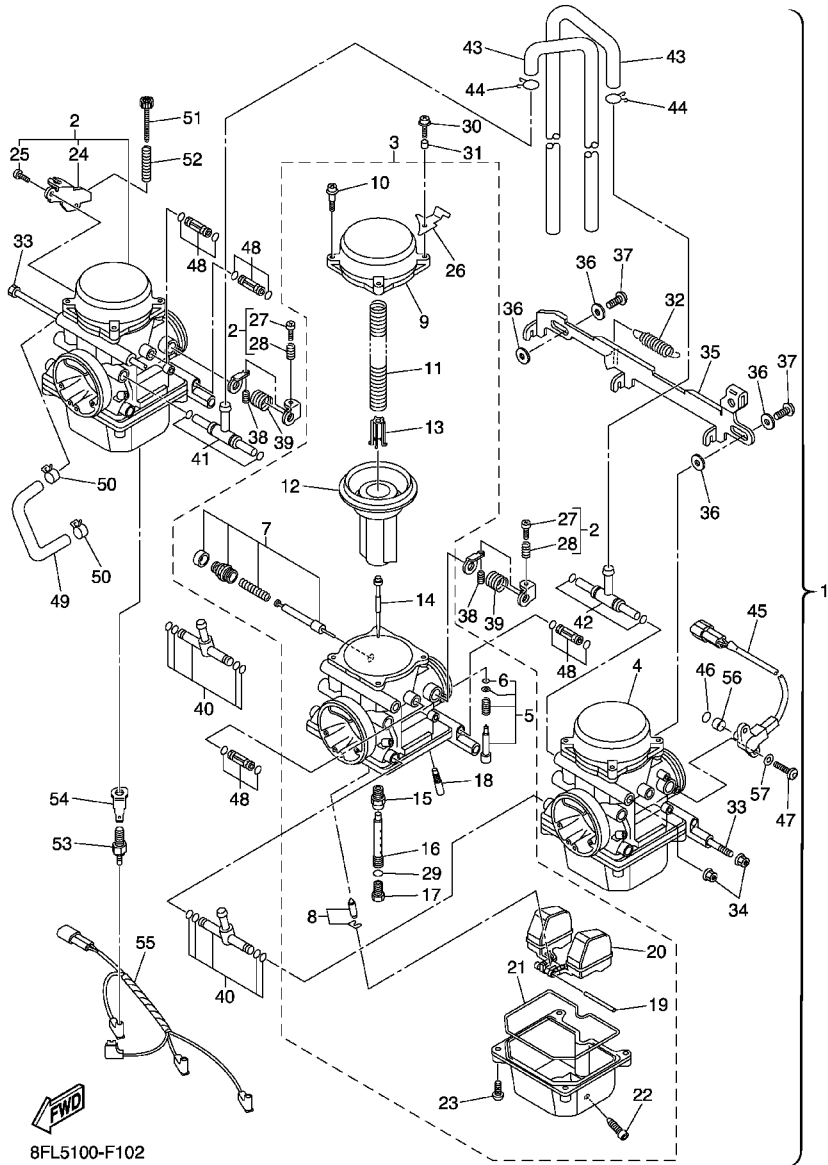
REF. NO.	PART NO.	DESCRIPTION	8GS5	8GS6	REMARKS
1	8ES-14900-02	CARBURETOR ASSY	1	1	
2	8ES-14901-01	.CARBURETOR ASSY 1	1	1	
3	8ES-14902-01	.CARBURETOR ASSY 2	1	1	
4	8ES-14903-01	.CARBURETOR ASSY 3	1	1	
5	8ES-14105-00	..PILOT SCREW SET	1	1	
6	8ES-14147-00	..O-RING	1	1	
7	8ES-1410A-00	..STARTER SET	1	1	
8	8ES-14107-00	..NEEDLE VALVE SET	1	1	
9	8ES-14958-00	..COVER, DIAPHRAGM	1	1	
10	4JH-14216-00	..SCREW	4	4	#1,3
	4JH-14216-00	..SCREW	3	3	#2
11	8ES-14933-00	..SPRING, DIAPHRAGM	1	1	
12	8ES-14940-00	..DIAPHRAGM ASSY	1	1	
13	4JH-14936-00	..SEAT, SPRING	1	1	
14	8ES-14916-00	..NEEDLE	1	1	
15	8ES-14947-00	..JET, NEEDLE	1	1	
16	8ES-1414G-00	..PIPE, MAIN BLEED	1	1	
17	3TJ-14943-87	..JET, MAIN (#148)	1	1	STD
	3TJ-14943-36	..JET, MAIN (#145)	1	1	AP
	3TJ-14943-37	..JET, MAIN (#150)	1	1	AP
18	8ES-14948-05	..JET (#45)	1	1	STD
	8ES-14948-03	..JET (#40)	1	1	AP
	8ES-14948-06	..JET (#48)	1	1	AP
	8ES-14948-07	..JET (#50)	1	1	AP
19	676-14548-00	..PIN, FLOAT ARM	1	1	
20	8ES-14985-00	..FLOAT	1	1	
21	8ES-14984-00	..GASKET, FLOAT CHAMBER	1	1	



8FL5100-F102

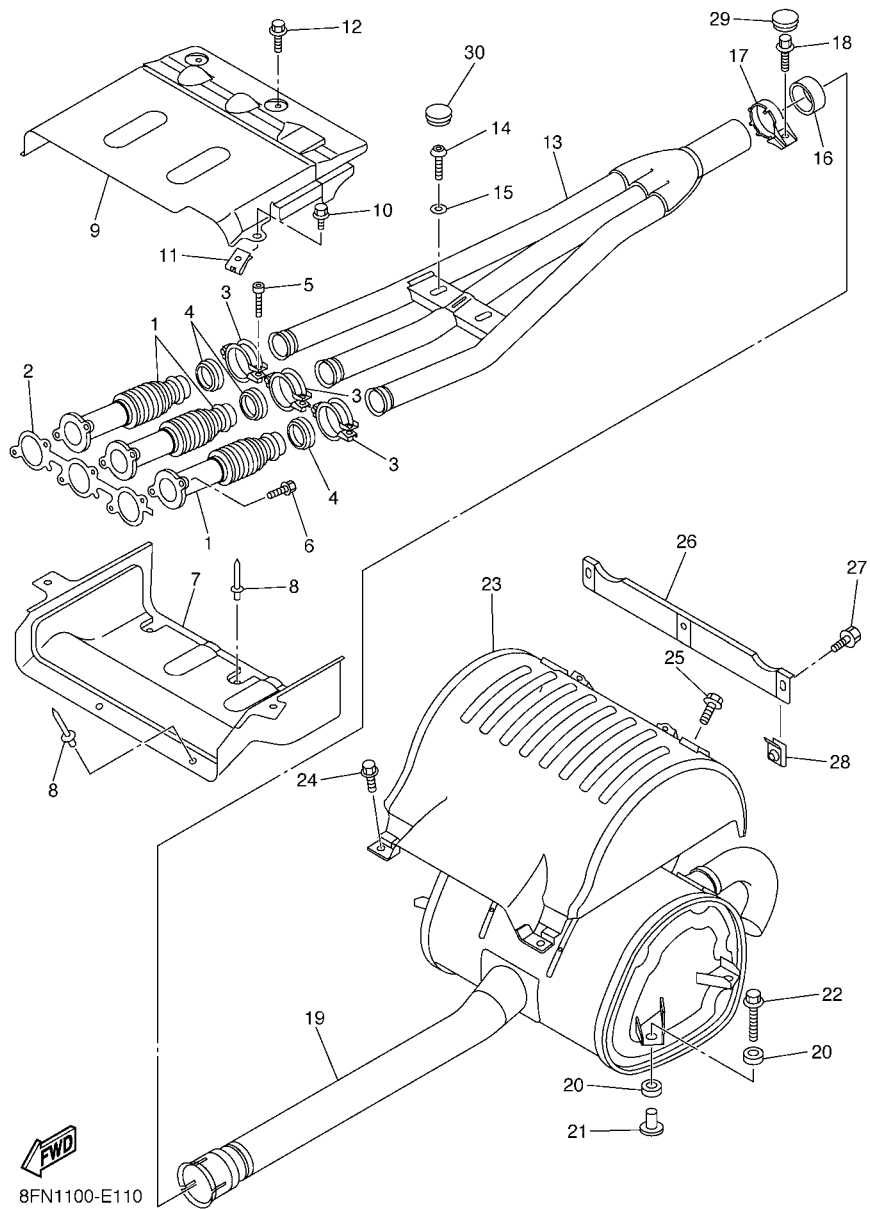
FIG. 10 CARBURETOR

REF. NO.	PART NO.	DESCRIPTION	8CS5	8CS6	REMARKS
22	3TJ-14191-40	..PLUG, DRAIN	1	1	
23	98502-04014	..SCREW, PAN HEAD	4	4	
24	8ES-14926-01	..BRACKET, THROTTLE 1	1	1	#1
25	8ES-14592-00	..SCREW	1	1	#1
26	4TV-14926-00	..BRACKET, THROTTLE 1	1	1	#2
27	4JH-14121-00	..SCREW, THROTTLE STOP	1	1	#1,2
28	7A9-14555-00	..SPRING	1	1	#1,2
29	8ES-14561-00	..O-RING	1	1	
30	8ES-14565-00	.SCREW	1	1	
31	4JH-14264-00	.COLLAR	1	1	
32	8ES-14935-00	.SPRING	1	1	
33	8ES-14162-00	.BOLT, HOLDING	2	2	
34	4JH-14358-00	.NUT	2	2	
35	8ES-14965-00	.LEVER, STARTER	1	1	
36	8ES-14578-00	.COLLAR	4	4	
37	8ES-14567-00	.SCREW	2	2	
38	4YR-14133-00	.SPRING, THROTTLE STOP	2	2	
39	4JH-14487-00	.SPRING	2	2	
40	8ES-14295-00	.PIPE, FUEL	2	2	
41	8ES-13815-00	.JOINT 1	1	1	
42	8ES-13816-00	.JOINT 2	1	1	
43	8ES-14197-01	.PIPE	2	2	
44	3TJ-14937-40	.CLIP	2	2	
45	8ES-85885-01	.THROTTLE SENSOR ASSY	1	1	
46	4TV-14562-00	.O-RING	1	1	
47	4YR-14216-00	.SCREW	2	2	
48	8ES-14454-00	.JOINT	4	4	



**FIG. 10 CARBURETOR**

REF. NO.	PART NO.	DESCRIPTION	8GS5	8GS6	REMARKS
49	8ES-14987-00	.HOSE	1	1	
50	4TV-12486-00	.CLIP	2	2	
51	8ES-14121-00	.SCREW, THROTTLE STOP	1	1	
52	4YR-14934-00	.SPRING, THROTTLE STOP	1	1	
53	5FU-83790-20	.HEATER ASSY (30W)	3	3	
54	8FA-82103-00	.TERMINAL 1	1	1	
55	8ES-81517-01	.WIRE, SUB LEAD	1	1	
56	4TV-14534-00	.COLLAR	1	1	
57	4YR-14557-00	.WASHER	2	2	



**FIG. 11 EXHAUST**

REF. NO.	PART NO.	DESCRIPTION	8CS5	8CS6	REMARKS
1	8ES-14615-01	JOINT, EXHAUST 1	3	3	
2	8ES-14613-00	GASKET, EXHAUST PIPE	1	1	
3	8FA-14715-00	BAND, MUFFLER	3	3	
4	8FA-14623-00	GASKET, EXHAUST PIPE	3	3	
5	91312-06030	BOLT	3	3	
6	95022-08020	BOLT, FLANGE	6	6	
7	8ES-14627-00	COVER, EXHAUST	1	1	
8	90267-47195	RIVET, BLIND (4.7X16.4 YELLOW)	3	3	
9	8FN-14637-00	EXHAUST COVER ASS'Y	1	1	
10	95812-06008	BOLT, FLANGE	2	2	
11	90183-060A0	NUT, SPRING	2	2	
12	95812-06016	BOLT, FLANGE	2	2	
13	8ES-14610-00	EXHAUST PIPE ASSY 1	1	1	
14	92012-08025	BOLT, BUTTON HEAD	2	2	
15	92990-08200	WASHER, PLAIN	2	2	
16	8FA-14714-10	GASKET, MUFFLER	1	1	
17	8FA-14788-00	BAND, SILENCER	1	1	
18	95812-08020	BOLT, FLANGE	1	1	
19	8FN-14750-00	SILENCER ASSY	1	1	
20	8FA-14737-00	DAMPER, MUFFLER	8	8	
21	90387-08071	COLLAR	4	4	
22	90119-08112	BOLT, WITH WASHER	4	4	
23	8ES-14708-02	PROTECTOR ASSY	1	1	
24	90119-06179	BOLT, WITH WASHER	2	2	
25	95812-06008	BOLT, FLANGE	2	2	
26	8ES-1478N-00	PLATE, 8	1	1	
27	95812-06008	BOLT, FLANGE	3	3	



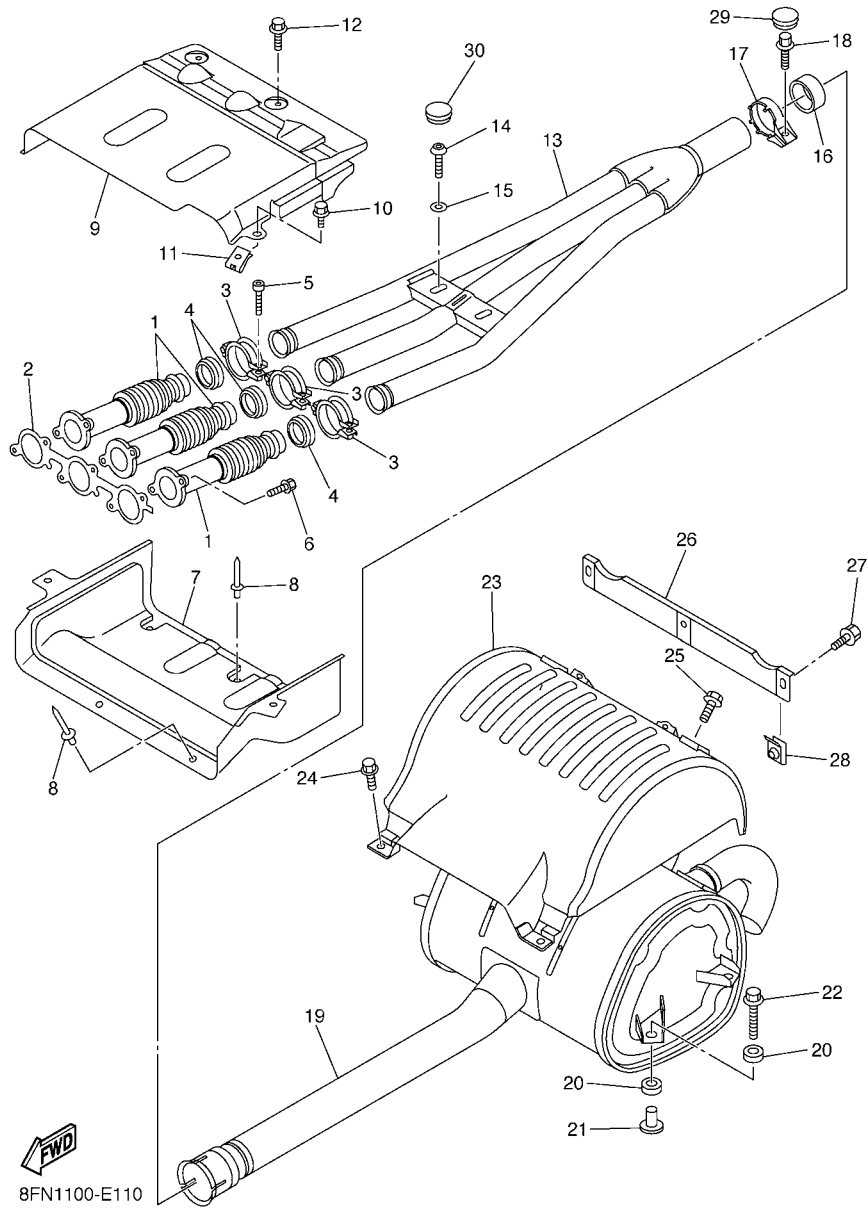
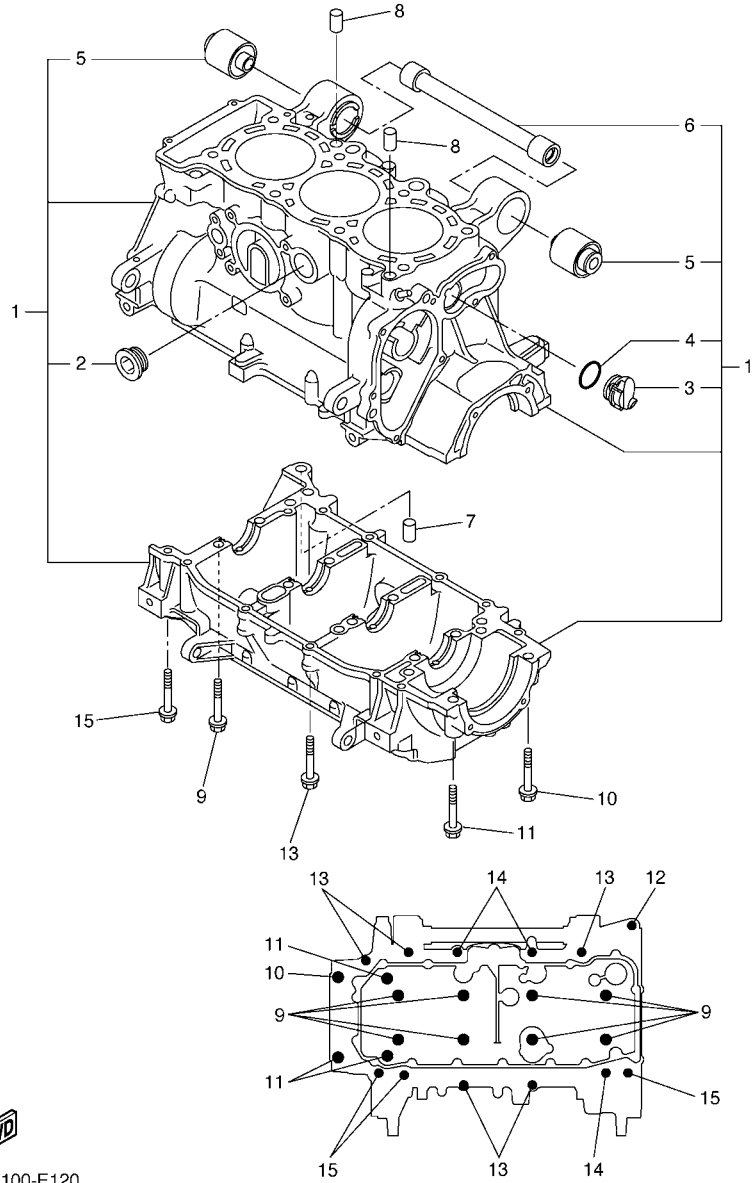


FIG. 11 EXHAUST

REF. NO.	PART NO.	DESCRIPTION	8CS5	8CS6		REMARKS
28	90183-060A0	NUT, SPRING	3	3		
29	90338-20004	PLUG	1	1		
30	90338-20007	PLUG	2	2		



8FJ3100-E120

FIG. 12 CRANKCASE

REF. NO.	PART NO.	DESCRIPTION	8GS5	8GS6		REMARKS
1	8ES-W1510-04	CRANKCASE ASSY	1	1		
2	90340-27001	.PLUG, STRAIGHT SCREW	1	1		
3	8ES-15167-00	.PLUG, BLIND 1	1	1		
4	93210-24709	.O-RING	1	1		
5	8FA-2139X-00	.DAMPER	2	2		
6	8ES-21459-00	.SPACER	1	1		
7	99530-10014	PIN, DOWEL	1	1		
8	99530-10114	PIN, DOWEL	2	2		
9	90119-09004	BOLT, WITH WASHER	8	8		
10	95812-08055	BOLT, FLANGE	1	1		
11	95812-08070	BOLT, FLANGE	3	3		
12	90109-06185	BOLT	1	1		
13	95812-06055	BOLT, FLANGE	5	5		
14	95812-06080	BOLT, FLANGE	3	3		
15	90105-06123	BOLT, FLANGE	3	3		



8ES1100-D130

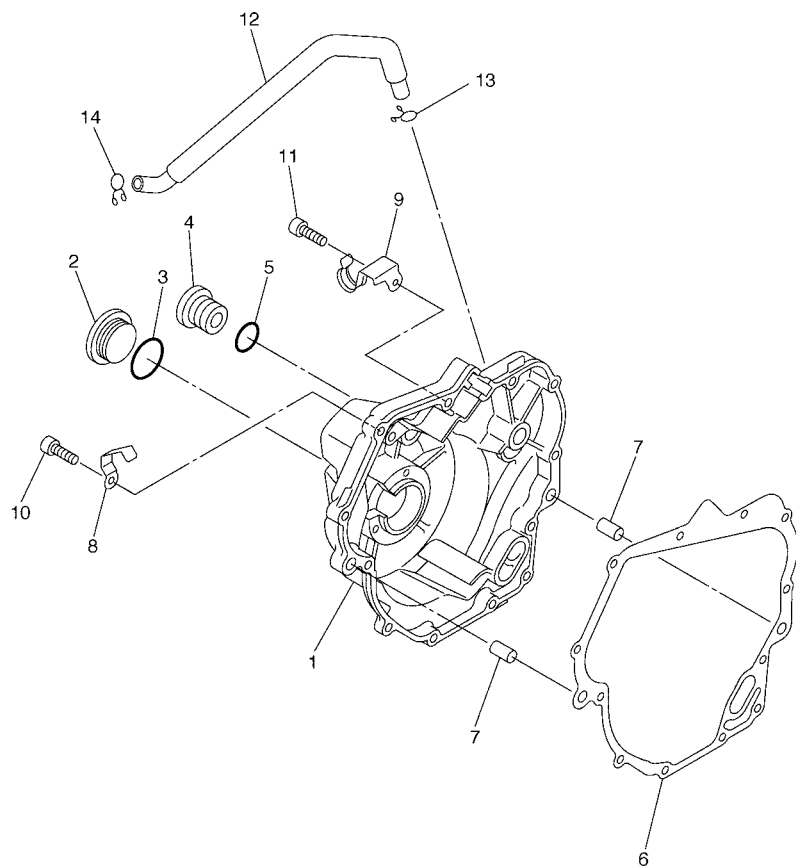
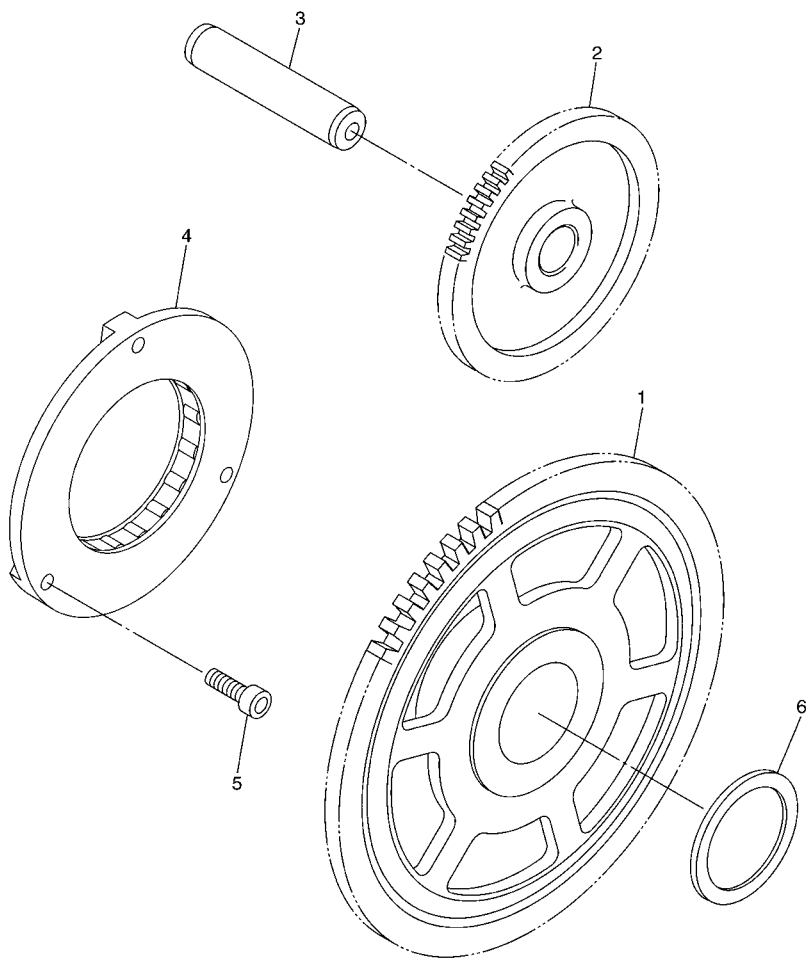


FIG. 13 CRANKCASE COVER 1

REF. NO.	PART NO.	DESCRIPTION	8GS5	8GS6		REMARKS
1	8ES-15421-01	COVER, CRANKCASE 2	1	1		
2	90340-32080	PLUG, STRAIGHT SCREW	1	1		
3	93210-32172	O-RING	1	1		
4	90340-14117	PLUG, STRAIGHT SCREW	1	1		
5	93210-14369	O-RING	1	1		
6	8ES-15461-01	GASKET, CRANKCASE COVER 2	1	1		
7	99530-08012	PIN, DOWEL	2	2		
8	90462-08225	CLAMP	1	1		
9	90465-10038	CLAMP	1	1		
10	90109-06015	BOLT	11	11		
11	90110-06234	BOLT, HEXAGON SOCKET HEAD	1	1		
12	8ES-1531A-00	HOSE, BREATHER 1	1	1		
13	90467-100A1	CLIP	1	1		
14	90467-11019	CLIP	1	1		

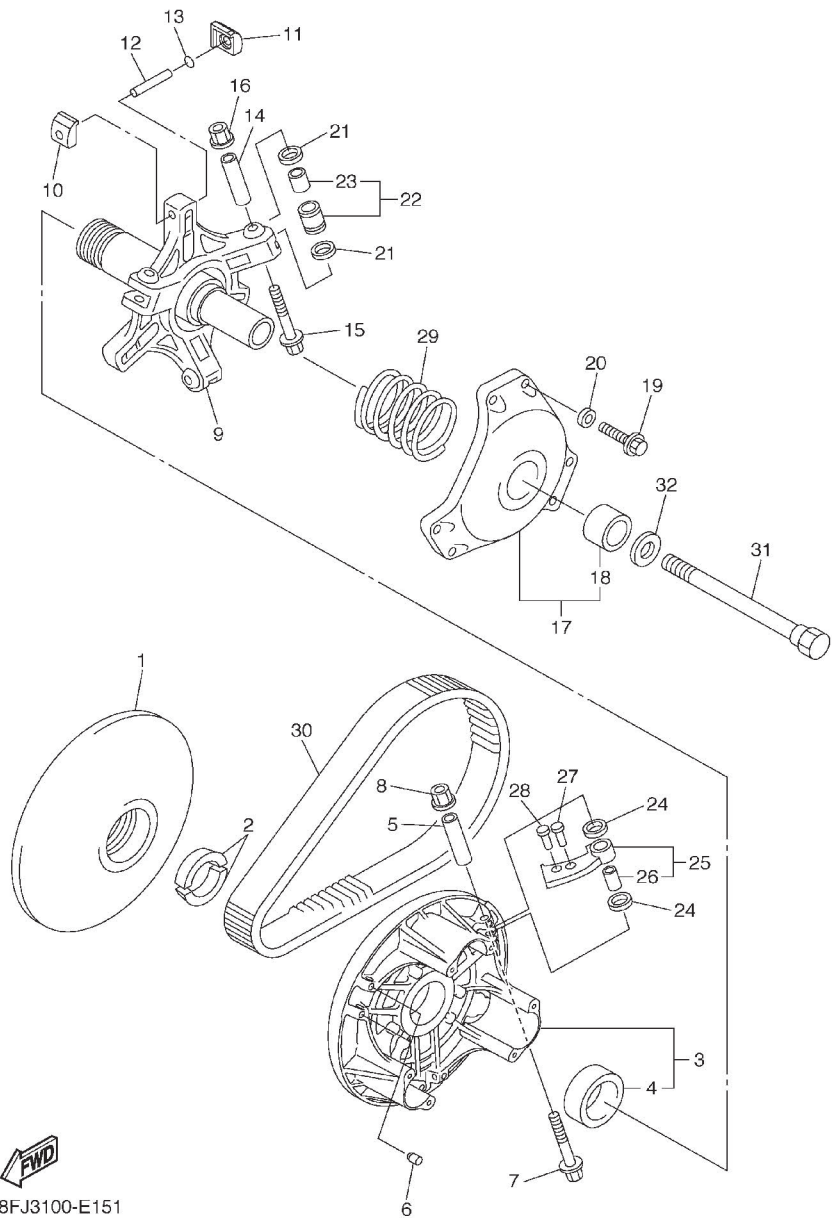
FIG. 14 STARTER



REF. NO.	PART NO.	DESCRIPTION	8GS5	8GS6				REMARKS
1	8FA-15515-00	GEAR 3	1	1				
2	8ES-15512-01	GEAR, IDLER 1	1	1				
3	8ES-15521-00	SHAFT 1	1	1				
4	8GL-15590-00	STARTER ONE-WAY ASSY	1	1				
5	90110-06168	BOLT, HEXAGON SOCKET HEAD	3	3				
6	90201-30013	WASHER, PLATE	1	1				



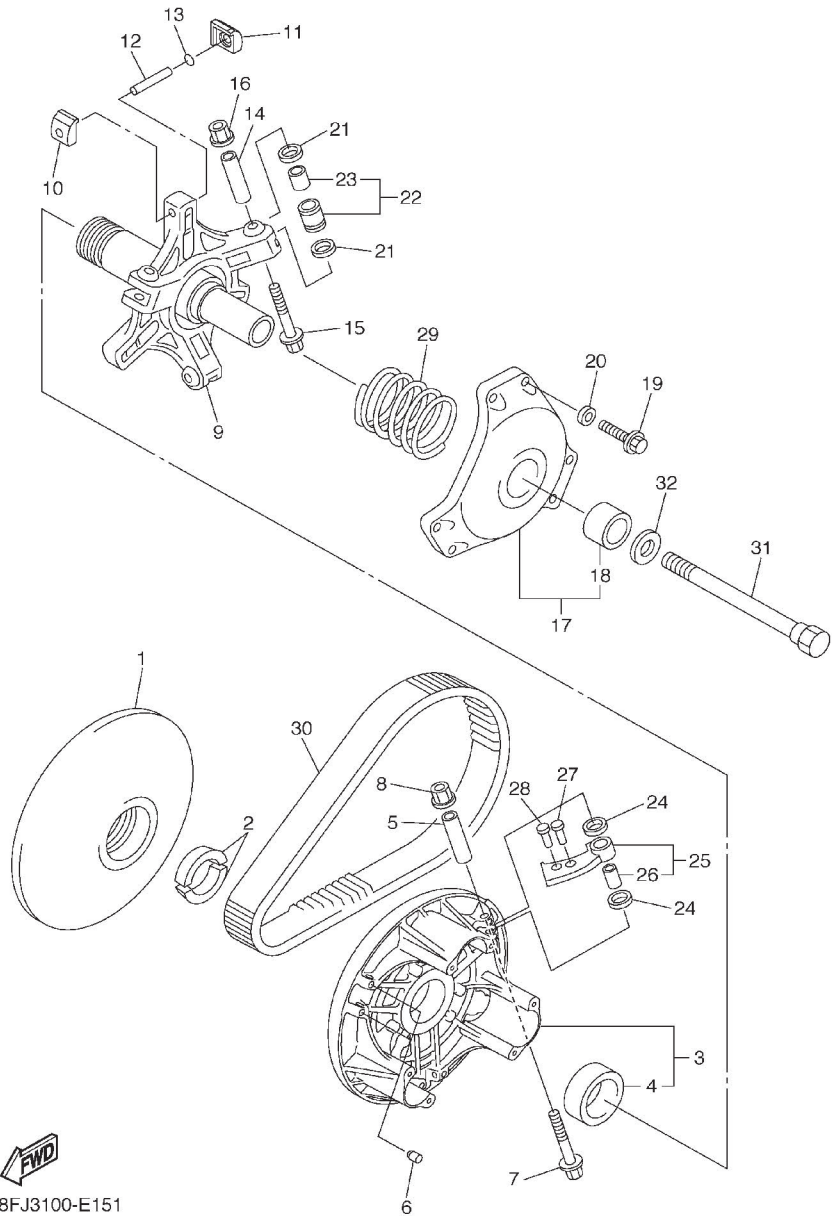
8GM1100-G140



8FJ3100-E151

FIG. 15 PRIMARY SHEAVE

REF. NO.	PART NO.	DESCRIPTION	8GS5	8GS6		REMARKS
1	8FA-17611-01	SHEAVE, PRIMARY FIXED	1	1		
2	8V0-17639-00	STOPPER	2	2		
3	8FP-17620-00	PRIMARY SLIDING SHEAVE COMP.	1	1		
4	90384-41242	.BUSH, BIMETAL FORMED	1	1		
5	90387-0514T	COLLAR	3	3		
6	90113-05053	BOLT, SET	6	6		
7	90105-05644	BOLT, FLANGE	3	3		
8	95607-05200	NUT, U FLANGE	3	3		
9	8GS-17640-01	SPIDER COMPLETE	1	1		
10	8BW-17653-00	SLIDER	3	3		
11	8ES-17653-00	SLIDER	3	3		
12	91609-50032	PIN, SPRING	3	3		
13	8ES-17655-00	DAMPER, SLIDER	3	3		
14	90387-0514U	COLLAR	3	3		
15	90105-05644	BOLT, FLANGE	3	3		
16	95607-05200	NUT, U FLANGE	3	3		
17	8DF-17630-00	PRIMARY SHEAVE CAP COMP.	1	1		
18	90380-28237	.BUSH, SOLID	1	1		
19	97017-06030	BOLT	6	6		
20	92907-06600	WASHER, PLATE	6	6		
21	90202-09227	WASHER, PLATE	6	6		
22	8FG-17624-20	ROLLER, COMP	3	3		
23	90386-09001	.BUSH	1	1		
24	90202-08204	WASHER, PLATE	6	6		
25	8FN-17605-00	WEIGHT COMP	3	3		
26	90386-08002	.BUSH	1	1		
27	90269-06006	RIVET (ST17.2)	3	3		IN



8FJ3100-E151

FIG. 15 PRIMARY SHEAVE

REF. NO.	PART NO.	DESCRIPTION	8GS5	8GS6		REMARKS
28	90261-06033	RIVET, COUNTERSUNK (ST17.2MM)	3	3		OUT
29	90501-550A3	SPRING, COMPRESSION	1	1		
30	8GS-17641-00	V-BELT	1	1		
31	8V0-17647-00	BOLT (L=156.5MM)	1	1		
32	92907-16100	WASHER	1	1		

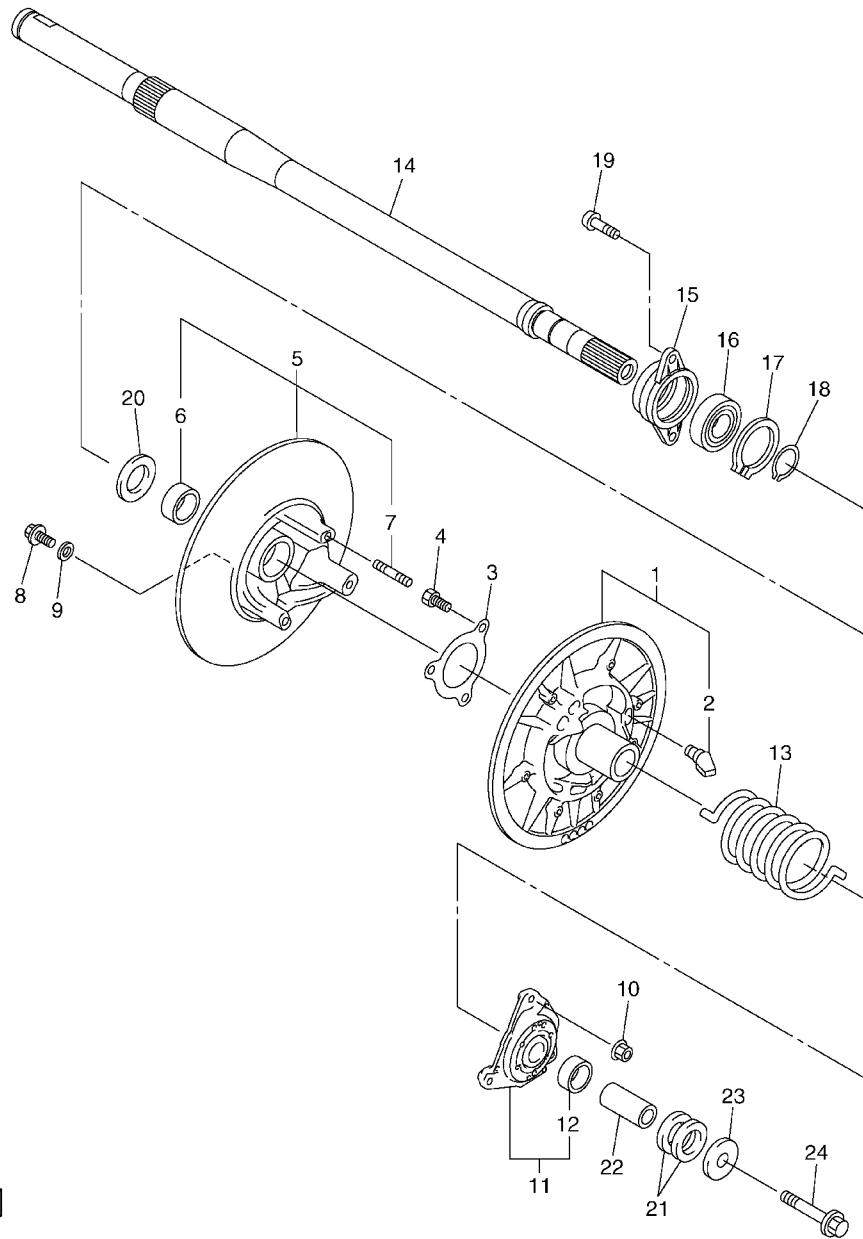
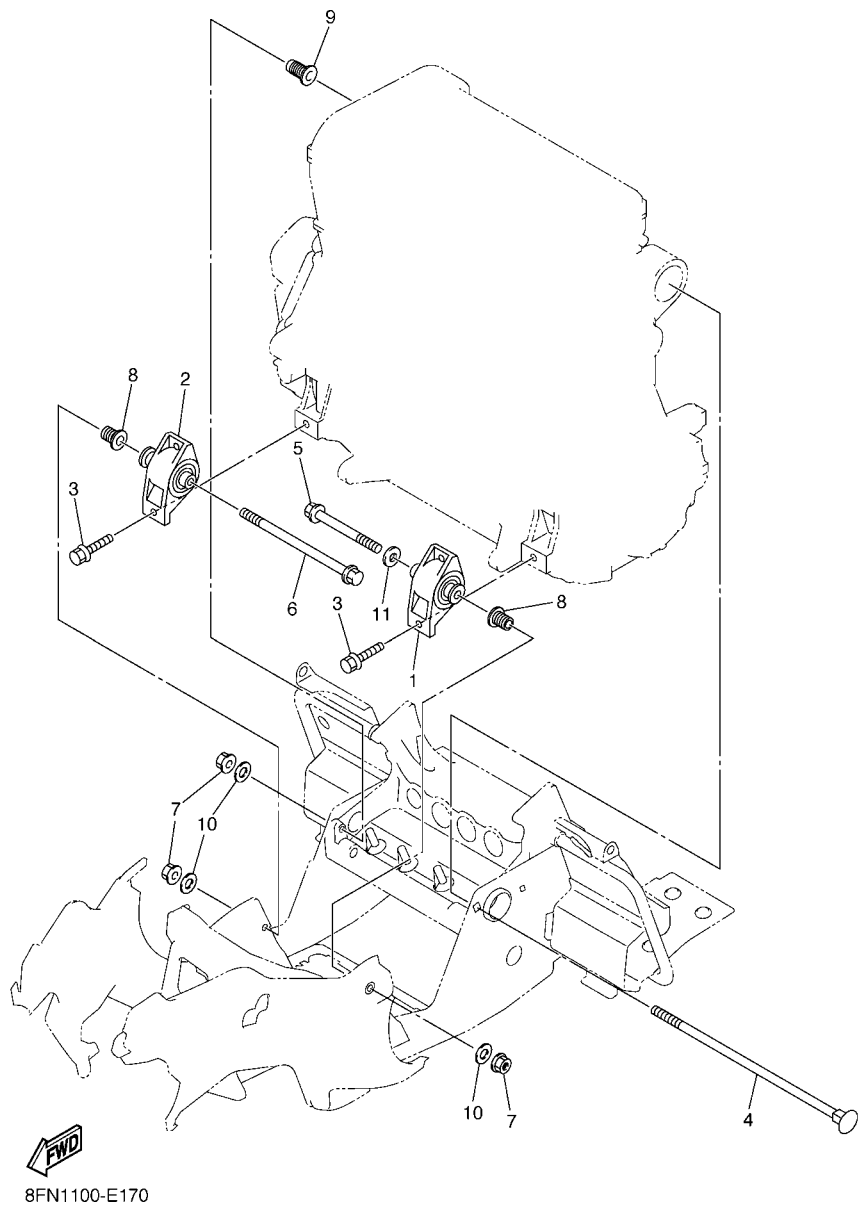


FIG. 16 SECONDARY SHEAVE

REF. NO.	PART NO.	DESCRIPTION	8GS	8GS		REMARKS
1	8CR-17660-20	SECONDARY FIXED SHEAVE COMP.	1	1		
2	8AV-17688-10	.SHOE, RAMP	3	3		
3	8BV-17656-00	STOPPER, HOLDER	1	1		
4	90154-06062	SCREW, BINDING	3	3		
5	8BU-17670-20	SECONDARY SLIDING SHEAVE	1	1		
6	90384-38243	.BUSH, BIMETAL FORMED	1	1		
7	95617-08630	.BOLT, STUD	3	3		
8	90105-06734	BOLT, FLANGE	3	3		
9	90201-06037	WASHER, PLATE (T=1.0)	3	3		UR UN
	90201-061H1	WASHER, PLATE (T=0.5)	3	3		UR UN
10	90179-08655	NUT	3	3		
11	8FN-17604-90	SEAT SPRING SET	1	1		
12	90384-38243	.BUSH, BIMETAL FORMED	1	1		
13	90508-60012	SPRING, TORSION	1	1		(PINK)
14	8GS-17681-00	SHAFT, SECONDARY	1	1		
15	8FN-47631-00	HOUSING, BEARING	1	1		
16	93306-30579	BEARING	1	1		
17	99009-62500	CIRCLIP	1	1		
18	99009-25400	CIRCLIP	1	1		
19	90149-08034	SCREW	2	2		
20	90201-25526	WASHER, PLATE (T2.0)	2	2		UN
21	90201-225A4	WASHER, PLATE (T=1.0)	3	3		UR UN
	90201-222F0	WASHER, PLATE (T=0.5)	1	1		UR UN
22	90387-1407L	COLLAR	1	1		
23	90201-141A3	WASHER, PLATE	1	1		
24	90105-14766	BOLT, FLANGE	1	1		



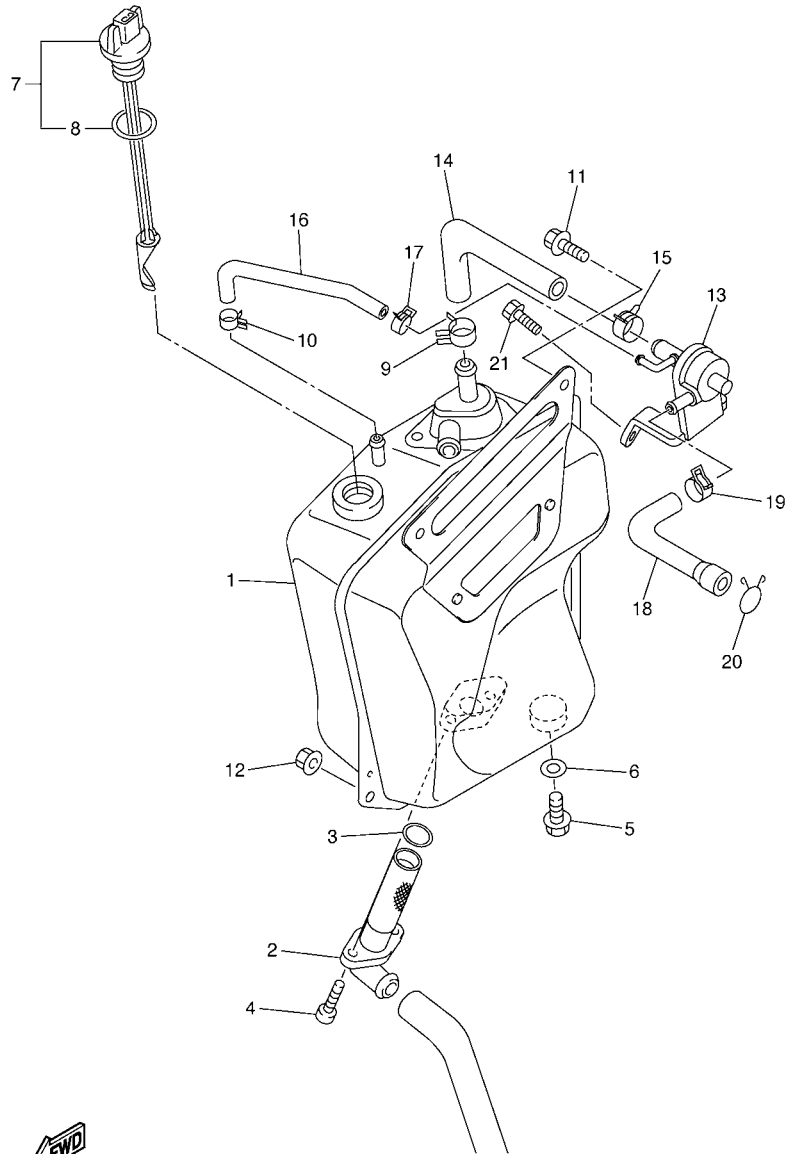
8GS1100-F161



**FIG. 17 ENGINE BRACKET**

REF. NO.	PART NO.	DESCRIPTION	8CS5	8CS6			REMARKS
			1	1			
1	8ES-21410-00	ENGINE BRACKET COMP.	1	1			
2	8ES-21420-00	ENGINE BRACKET COMP. 2	1	1			
3	95812-08030	BOLT, FLANGE	4	4			
4	8FN-21481-00	BOLT, ENGINE MOUNTING 1	1	1			
5	95817-12100	BOLT, FLANGE	1	1			
6	95817-12200	BOLT, FLANGE	1	1			
7	90179-12004	NUT	3	3			
8	8FG-21495-00	BOLT, ENGINE ADJUSTING	2	2			
9	8FG-2149C-00	BOLT	1	1			
10	90201-120T5	WASHER, PLATE	3	3			
11	90201-125A3	WASHER, PLATE	1	1			





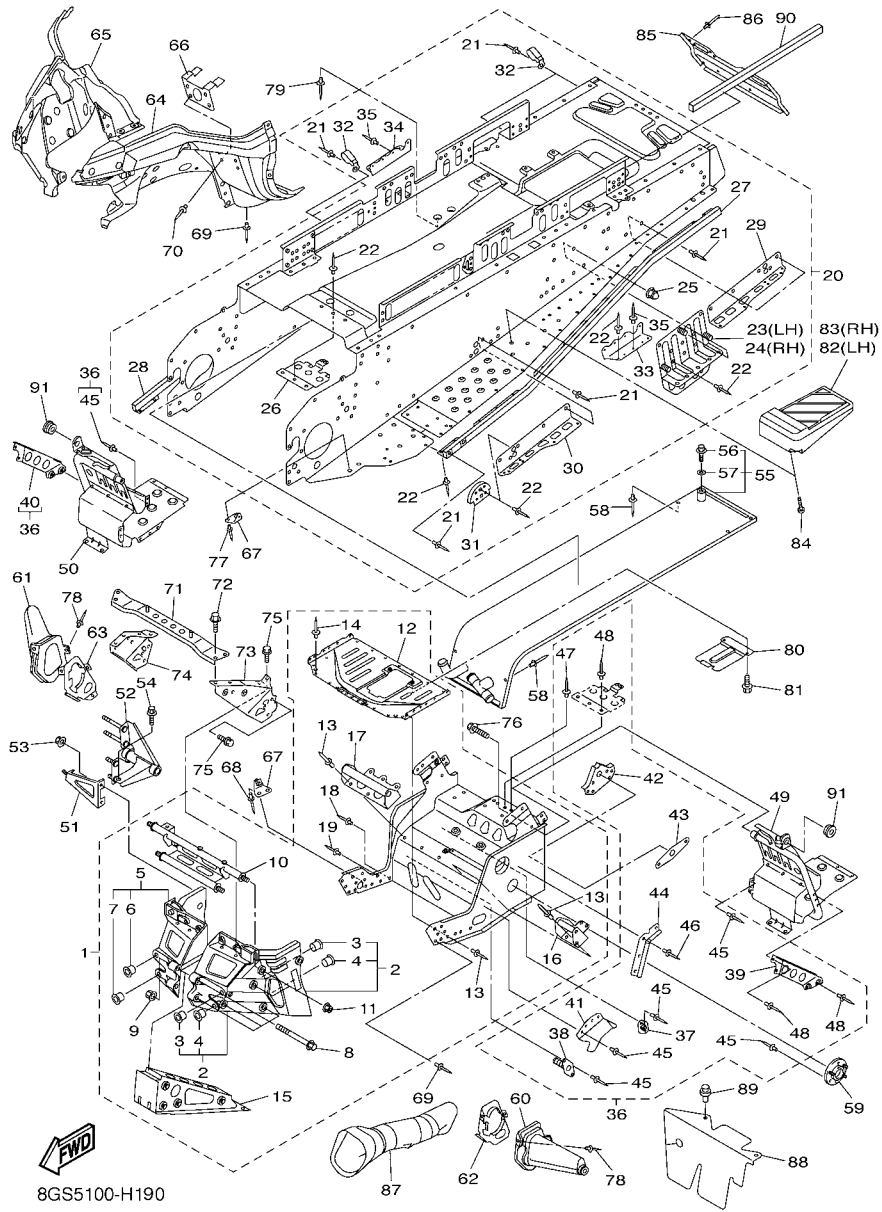
8FN1100-E180

FIG. 18 OIL TANK

REF. NO.	PART NO.	DESCRIPTION	8GS5	8GS6		REMARKS
1	8FG-21751-02	TANK, OIL	1	1		
2	8FG-13406-00	OIL PIPE COMP. 2	1	1		
3	93210-19026	O-RING	1	1		
4	91317-06016	BOLT	2	2		
5	95807-08012	BOLT, FLANGE	1	1		
6	90430-08204	GASKET	1	1		
7	8FA-85720-01	OIL LEVEL GAUGE ASSY	1	1		
8	8FP-85075-00	.O-RING	1	1		
9	90468-08104	CLIP	1	1		
10	90467-12053	CLIP	1	1		
11	95812-06016	BOLT, FLANGE	2	2		
12	95602-08200	NUT, SELF-LOCKING	1	1		
13	8FN-13520-00	VALVE ASSY.	1	1		
14	8ES-21745-00	PIPE, OIL TANK BREATHER	1	1		
15	90468-08104	CLIP	1	1		
16	8ES-2174N-00	PIPE, OIL TANK	1	1		
17	90467-12053	CLIP	1	1		
18	8FN-21816-00	PIPE 1	1	1		
19	90467-20085	CLIP	1	1		
20	90467-22080	CLIP	1	1		
21	95822-06020	BOLT, FLANGE	2	2		

FIG. 19 FRAME

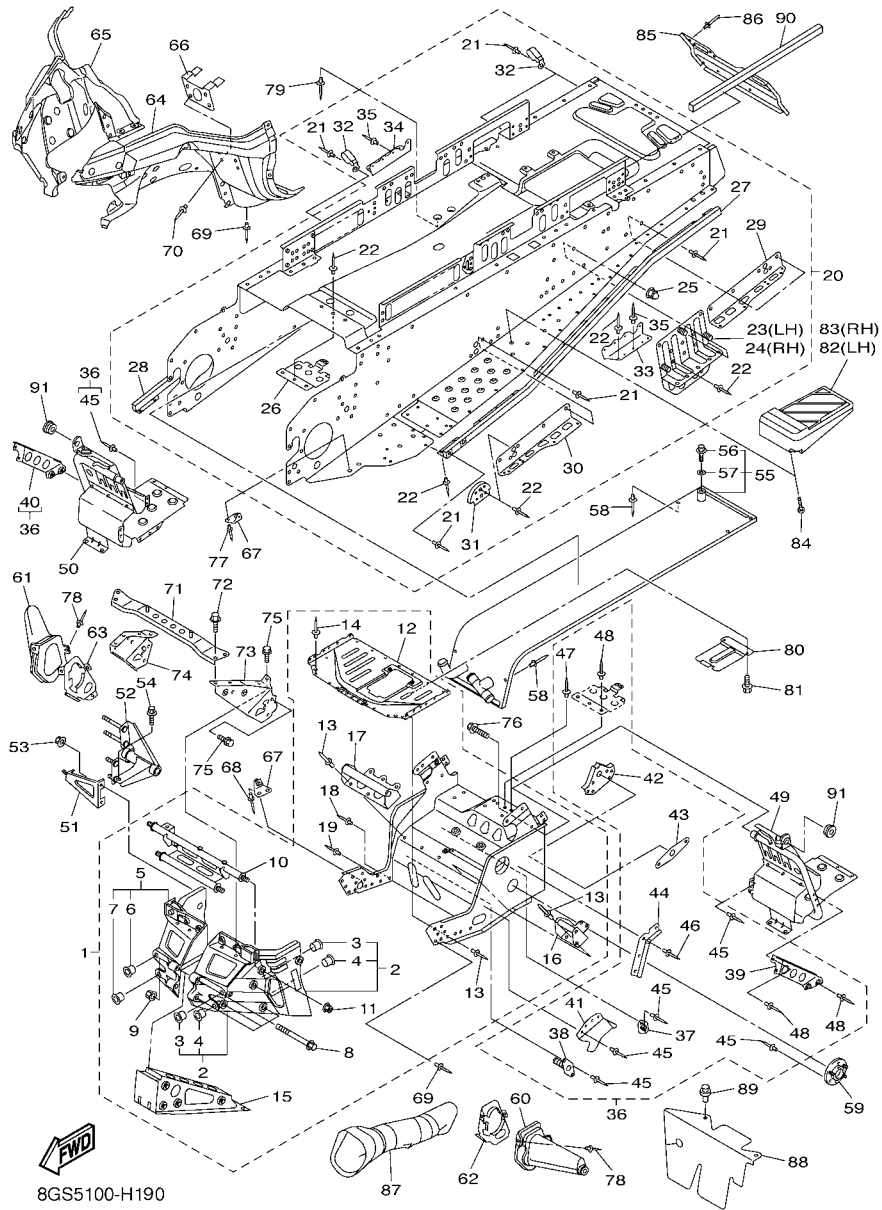
REF. NO.	PART NO.	DESCRIPTION	8GS5	8GS6	REMARKS
1	8GS-21940-10	FRONT FRAME COMP.	1	1	
2	8FN-W2197-00	.BULKHEAD	1	1	
3	90381-15001	..BUSH, SOLID	2	2	
4	90381-16001	..BUSH, SOLID	2	2	
5	8FN-W2198-00	.BULKHEAD 2	1	1	
6	90381-15001	..BUSH, SOLID	2	2	
7	90381-16001	..BUSH, SOLID	2	2	
8	90105-08072	.BOLT, FLANGE	4	4	
9	95607-08200	.NUT, SELF-LOCKING	4	4	
10	8FN-21947-00	.BRACKET, STEERING 1	1	1	
11	95607-10200	.NUT, U FLANGE	4	4	
12	8GS-2193A-00	.PROTECTOR	1	1	
13	90267-47195	.RIVET, BLIND (4.7X16.4 YELLOW)	57	57	
14	90267-48016	.RIVET, BLIND (4.8X16.4 YELLOW)	21	21	
15	8FN-2198E-00	.REINFORCEMENT, FRAME 3	1	1	
16	8FN-2194F-00	.BRACKET, ENGINE 2	1	1	
17	8FN-2194G-00	.BRACKET, ENGINE 3	1	1	
18	90267-48176	.RIVET, BLIND (4.8X17 YELLOW)	2	2	
19	90267-48177	.RIVET, BLIND (4.8X14 YELLOW)	1	1	
20	8GS-21950-01	REAR FRAME COMP.	1	1	
21	90267-48023	.RIVET, BLIND (4.8X12.1 YELLOW)	99	99	
22	90267-48177	.RIVET, BLIND (4.8X14 YELLOW)	89	89	
23	8FN-21944-01	.BRACKET, RR.TRACK SUSPENTION 1	1	1	
24	8FN-21954-01	.BRACKET, RR.TRACK SUSPENTION 2	1	1	
25	90176-10075	.NUT, CROWN	6	6	
26	8FN-2194H-00	.PROTECTOR, MUFFLER	1	1	
27	8FN-21926-00	.REINFORCEMENT, FOOTREST 1	1	1	



8GS5100-H190

FIG. 19 FRAME

REF. NO.	PART NO.	DESCRIPTION	8GS5	8GS6	REMARKS
28	8FN-21936-00	.REINFORCEMENT, FOOTREST 2	1	1	
29	8FN-21962-01	.PATCH 2	2	2	
30	8FN-21963-01	.PATCH 3	2	2	
31	8CW-21943-00	.BRACKET, MAIN TRACK 1	2	2	
32	90465-08368	.CLAMP	7	7	
33	8GS-21965-00	.PATCH 5	1	1	
34	8GS-21966-00	.PATCH 6	1	1	
35	90267-48176	.RIVET, BLIND (4.8X17 YELLOW)	16	16	
36	8GS-W2195-00	FRAME CONNECTION KIT	1	1	
37	8CR-21939-01	.BRACKET, CHAIN HOUSING	1	1	
38	8FN-21939-00	.BRACKET, CHAIN HOUSING	1	1	
39	8FG-2196M-00	.BRACKET, 5	1	1	
40	8FG-2197M-00	.BRACKET, 6	1	1	
41	8FU-2198G-00	.COVER 2	1	1	
42	8GS-21943-00	.BRACKET, MAIN TRACK 1	2	2	
43	8FN-21953-00	.BRACKET, MAIN TRACK 2	2	2	
44	8FA-21999-00	.CLAMP, WIREHARNES	1	1	
45	90267-47195	.RIVET, BLIND (4.7X16.4 YELLOW)	60	60	UN
46	90267-48018	.RIVET, BLIND (4.8X18.6 BLACK)	4	4	
47	90267-48023	.RIVET, BLIND (4.8X12.1 YELLOW)	6	6	
48	90267-48177	.RIVET, BLIND (4.8X14 YELLOW)	10	10	
49	8FN-21960-01	FOOTREST COMP. 1	1	1	
50	8GS-21970-00	FOOTREST COMP. 2	1	1	
51	8FN-2193E-00	BRACKET, OIL TANK 1	1	1	
52	8FN-2194E-00	BRACKET, ENGINE	1	1	
53	95602-08200	NUT, SELF-LOCKING	2	2	
54	95822-10016	BOLT, FLANGE	1	1	



8GS5100-H190

FIG. 19 FRAME

REF. NO.	PART NO.	DESCRIPTION	8GS5	8GS6	REMARKS
55	8FN-12440-00	HEAT EXCHANGER ASSY	1	1	
56	95812-06016	.BOLT, FLANGE	1	1	
57	90210-06006	.WASHER, SEAL	1	1	
58	90267-48016	RIVET, BLIND (4.8X16.4 YELLOW)	8	8	
59	8EK-21920-01	HOUSING, REINF SUB-ASSY(L.H)	1	1	
60	8FU-2198F-00	COVER 1	1	1	
61	8FU-2198J-00	COVER 3	1	1	
62	8FU-2195E-01	PLATE, STRG BRACKET 1	1	1	
63	8FU-2195F-01	PLATE, STRG BRACKET 2	1	1	
64	8ES-2196A-00	FRAME UNDER 1	1	1	
65	8FA-2196E-00	FRAME, UNDER 2	1	1	
66	8FA-21972-01	BRACKET, GUARD FITTING	1	1	
67	8FA-2196F-00	BRACKET 3	6	6	
68	90267-48083	RIVET,BLIND (4.8X15.2 SILVER)	8	8	
69	90267-48018	RIVET, BLIND (4.8X18.6 BLACK)	14	14	
70	90267-47200	RIVET, BLIND (4.7X19.5 BLACK)	4	4	
71	8FN-77512-00	BUMPER, FRONT 2	1	1	
72	95822-06012	BOLT, FLANGE	4	4	
73	8FN-21949-00	BRACKET, FRONT	1	1	
74	8FN-21959-00	BRACKET, FRONT BUMPER	1	1	
75	95822-08016	BOLT, FLANGE	6	6	
76	95822-08020	BOLT, FLANGE	2	2	
77	90267-48095	RIVET,BLIND (4.8X12.6 SILVER)	4	4	
78	90267-47195	RIVET, BLIND (4.7X16.4 YELLOW)	6	6	
79	90267-48016	RIVET, BLIND (4.8X16.4 YELLOW)	6	6	
80	8FR-2197E-00	PROTECTOR, FRAME FR	1	1	
81	92012-06012	BOLT, BUTTON HEAD	2	2	

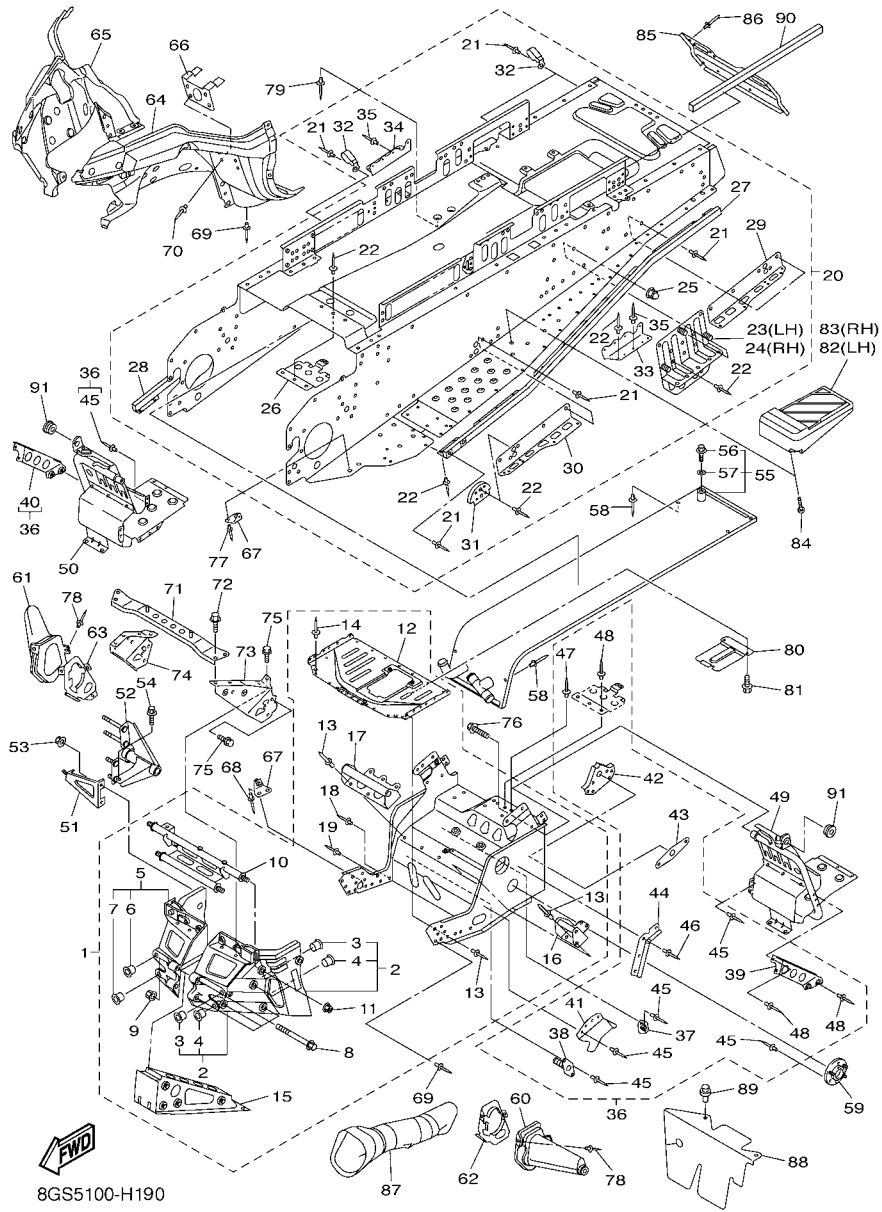
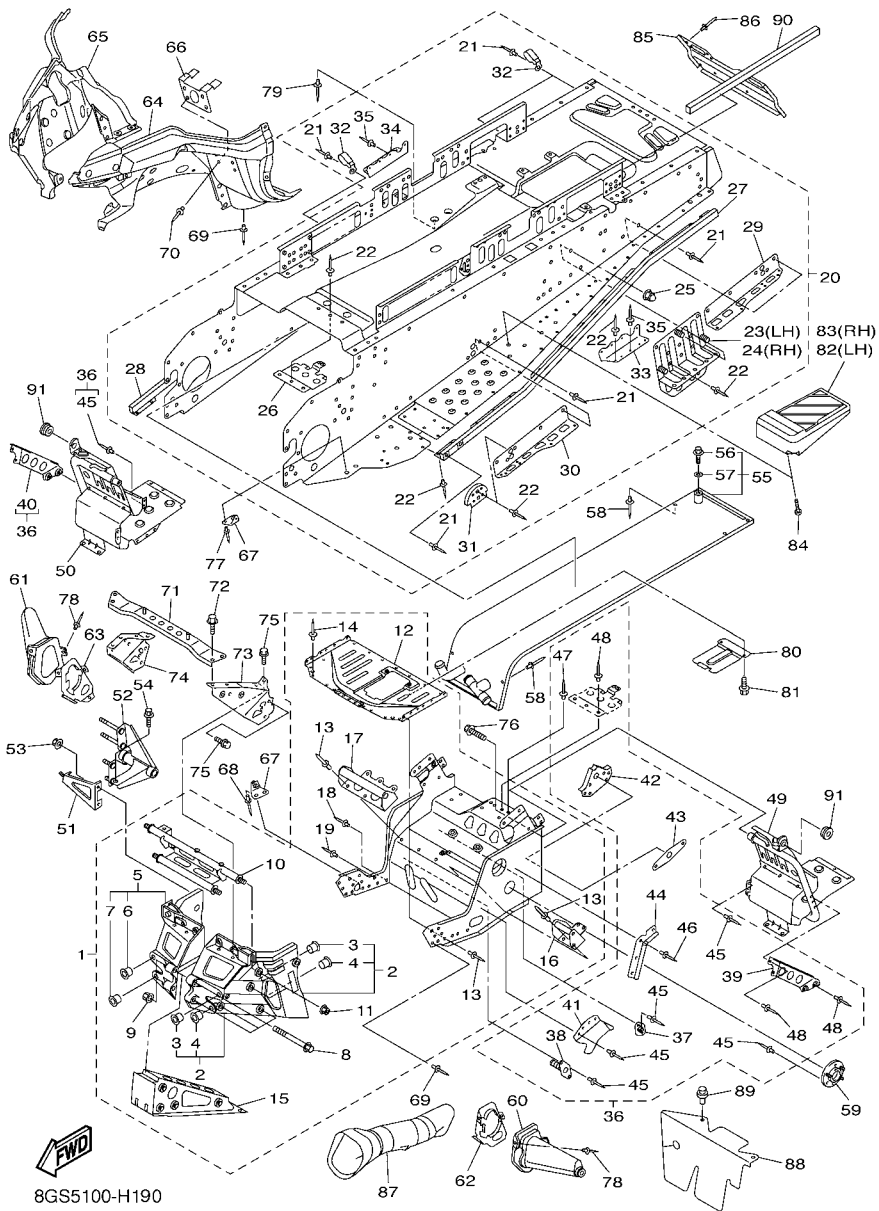
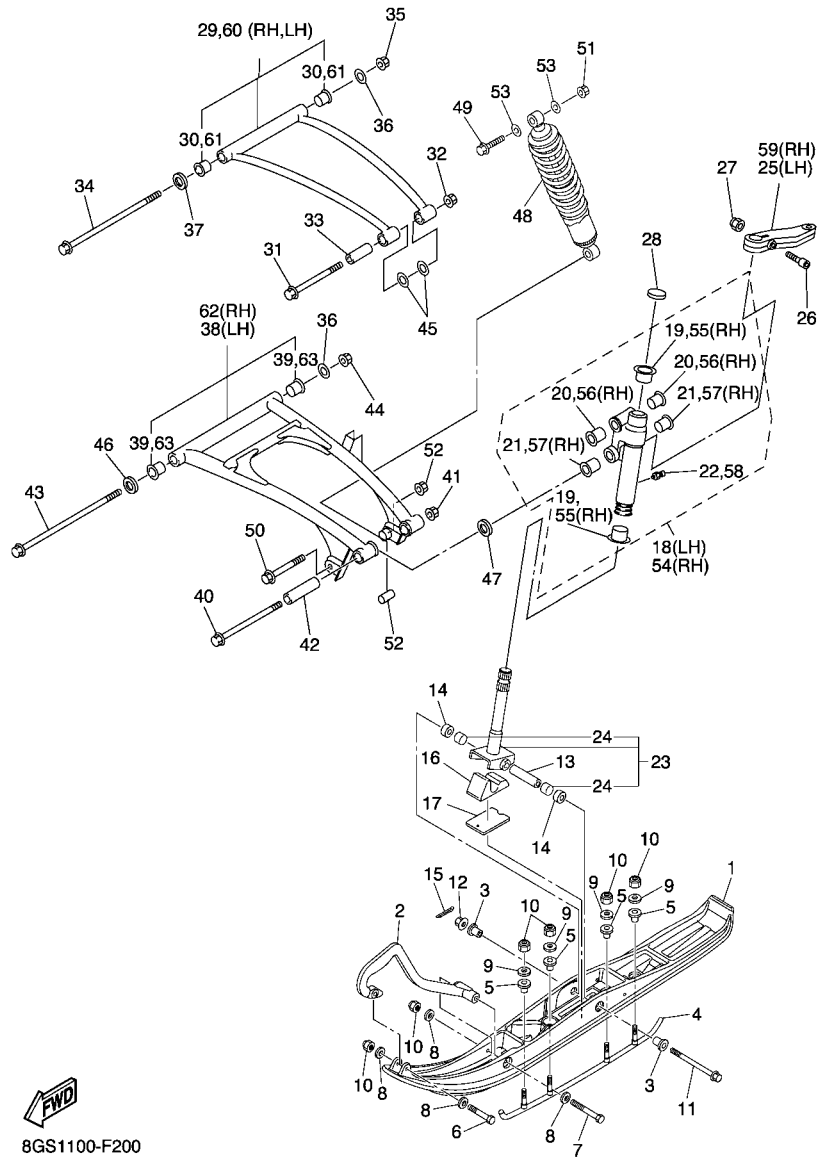


FIG. 19 FRAME

REF. NO.	PART NO.	DESCRIPTION	8GS5	8GS6	REMARKS
82	8DM-27431-02	FOOTREST, REAR 1	1	1	
83	8DM-27441-02	FOOTREST, REAR 2	1	1	
84	97702-50020	SCREW, TAPPING	8	8	
85	8FN-21933-01	REINFORCEMENT, FRAME REAR 2	1	1	
86	90267-47195	RIVET, BLIND (4.7X16.4 YELLOW)	8	8	
87	8FN-21557-00	DUCT, AIR	1	1	
88	8FN-2198F-00	COVER 1	1	1	
89	90269-09002	RIVET	2	2	
90	8FN-241A5-00	SEAL, 5	1	1	
91	90480-16278	GROMMET	2	2	

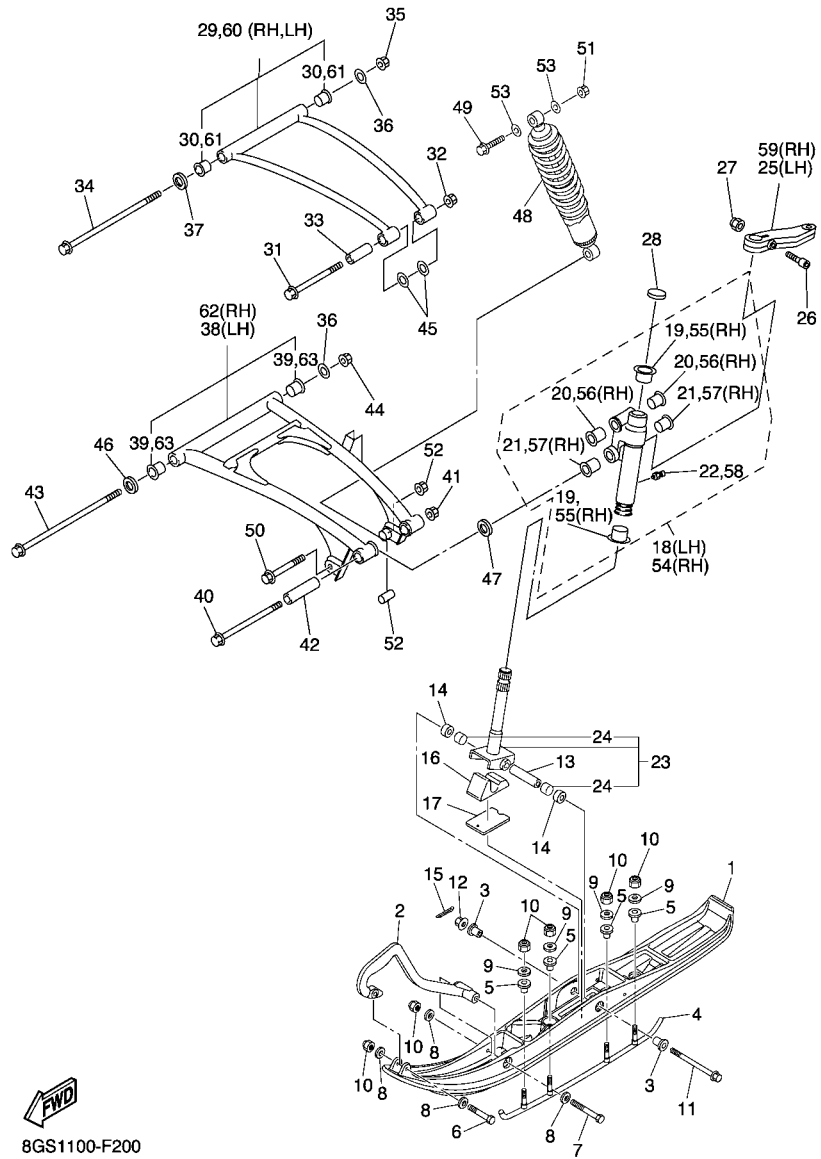




8GS1100-F200

FIG. 20 SKI

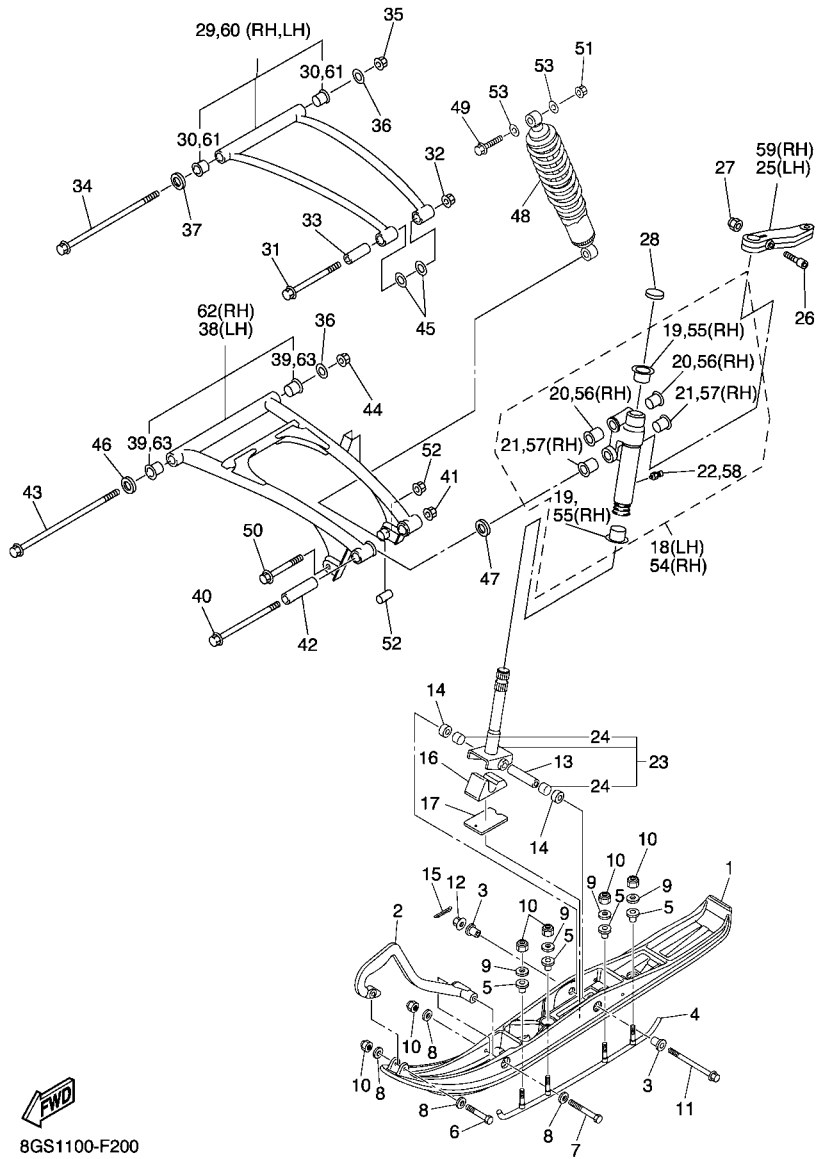
REF. NO.	PART NO.	DESCRIPTION	8GS5	8GS6	REMARKS
1	8FN-F3711-00	SKI 1	2		
	8FN-23711-00	SKI 1		2	
2	8DM-F3712-00	REINFORCEMENT, HEAD	2		
	8DM-23712-00	REINFORCEMENT, HEAD		2	
3	8EX-F3754-00	COLLAR, 1	4		
	8EX-23754-00	COLLAR, 1		4	
4	8EN-F3731-01	RUNNER 1	2		
	8EN-23731-01	RUNNER 1		2	
5	8EK-F3751-00	BUSH, SKI 1	8		
	8EK-23751-00	BUSH, SKI 1		8	
6	9702M-08055	BOLT	2		
	97027-08055	BOLT, HEXAGON		2	
7	9702M-08100	BOLT	2		
	97027-08100	BOLT, HEXAGON		2	
8	90201-08784	WASHER, PLATE	8	8	
9	90201-086P8	WASHER, PLATE	8	8	
10	9570M-08300	NUT, NYLON	12		
	95707-08300	NUT, NYLON		12	
11	90105-10106	BOLT, FLANGE	2	2	
12	95607-10200	NUT, U FLANGE	2	2	
13	90387-1012H	COLLAR	2	2	
14	90387-10029	COLLAR	4	4	
15	91401-20020	PIN, COTTER	2	2	
16	8ES-23743-00	STOPPER 1	2	2	
17	8FM-23744-00	STOPPER 2	2	2	
18	8ES-23501-00	STEERING KNUCKLE ASSY (LEFT)	1	1	
19	90381-25115	.BUSH, SOLID	2	2	



8GS1100-F200

FIG. 20 SKI

REF. NO.	PART NO.	DESCRIPTION	8GS5	8GS6	REMARKS
20	90381-15N50	.BUSH, SOLID	2	2	
21	90381-18N51	.BUSH, SOLID	2	2	
22	93700-06004	.NIPPLE, GREASE	1	1	
23	8ES-23803-00	COLUMN, SKI ASSY	2	2	
24	90384-16N51	.BUSH, BIMETAL FORMED	2	2	
25	8FN-23851-00	ARM, OUTSIDE 1	1	1	
26	90110-08N53	BOLT, HEXAGON SOCKET HEAD	2	2	
27	95607-08200	NUT, SELF-LOCKING	2	2	
28	3YK-22472-40	CAP, CASE	2	2	
29	8FN-23540-00	FRONT UPPER ARM COMP. (LEFT)	1	1	
30	90381-15N50	.BUSH, SOLID	2	2	
31	90105-10N51	BOLT, FLANGE	2	2	
32	95607-10200	NUT, U FLANGE	2	2	
33	90387-10N58	COLLAR	2	2	
34	90105-10N54	BOLT, FLANGE	2	2	
35	95607-10200	NUT, U FLANGE	2	2	
36	90201-106F2	WASHER, PLATE	4	4	
37	90209-15N50	WASHER	4	4	
38	8FN-23570-00	FRONT LOWER ARM COMP. (LEFT)	1	1	
39	90381-16N51	.BUSH, SOLID	2	2	
40	90105-12N54	BOLT, FLANGE	2	2	
41	95607-12200	NUT, SELF-LOCKING	2	2	
42	90387-12N54	COLLAR	2	2	
43	90105-10N55	BOLT, FLANGE	2	2	
44	95607-10200	NUT, U FLANGE	2	2	
45	90201-106F2	WASHER, PLATE	4	4	
46	90209-15N50	WASHER	4	4	



8GS1100-F200

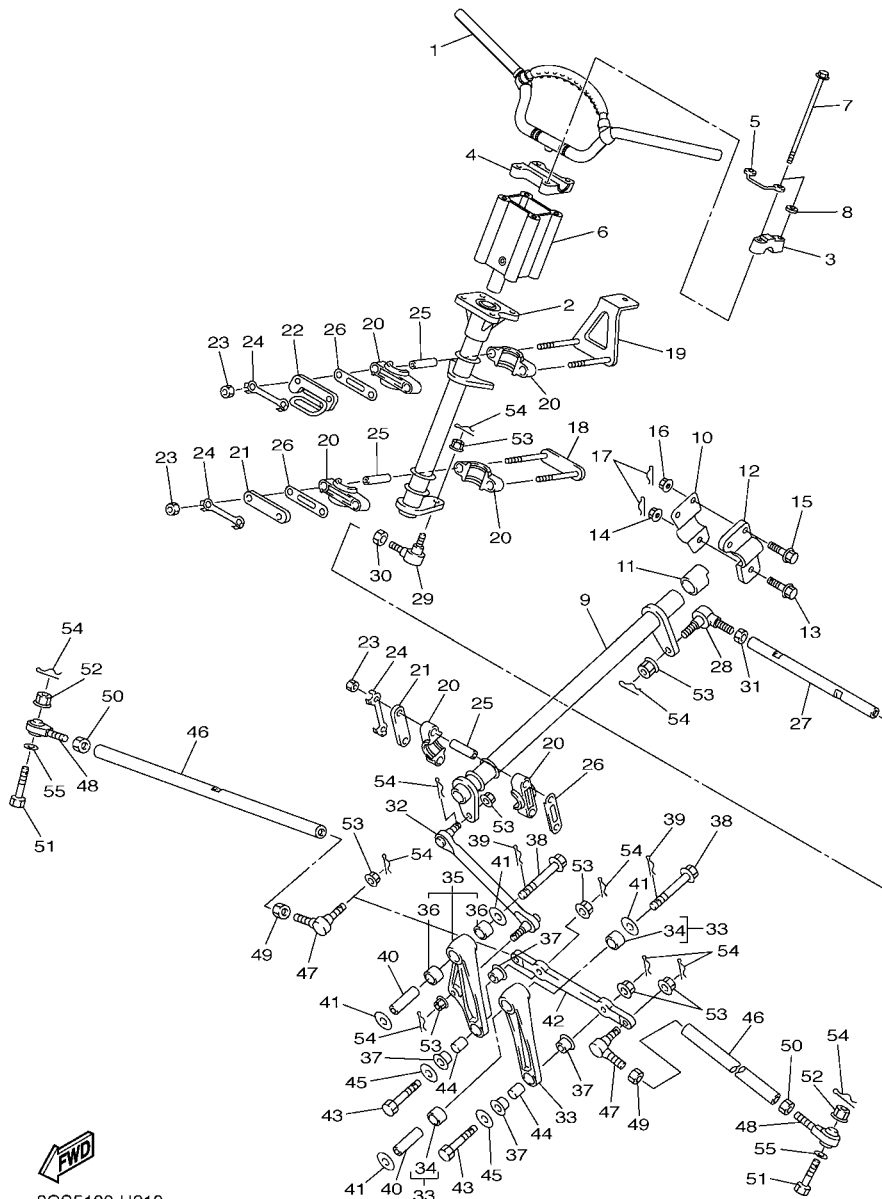
FIG. 20 SKI

REF. NO.	PART NO.	DESCRIPTION	8GS5	8GS6	REMARKS
47	90201-12032	WASHER, PLATE	4	4	
48	8FN-2376A-00	ABSORBER ASSY 1	2	2	
49	90105-10232	BOLT, FLANGE	2	2	
50	90105-10392	BOLT, FLANGE	2	2	
51	95607-10200	NUT, U FLANGE	4	4	
52	90387-10N59	COLLAR	2	2	
53	90201-106F2	WASHER, PLATE	4	4	
54	8ES-23502-00	STEERING KNUCKLE ASSY (RIGHT)	1	1	
55	90381-25115	.BUSH, SOLID	2	2	
56	90381-15N50	.BUSH, SOLID	2	2	
57	90381-18N51	.BUSH, SOLID	2	2	
58	93700-06004	.NIPPLE, GREASE	1	1	
59	8FN-23852-00	ARM, OUTSIDE 2	1	1	
60	8FN-23550-00	FRONT UPPER ARM COMP. (RIGHT)	1	1	
61	90381-15N50	.BUSH, SOLID	2	2	
62	8FN-23580-00	FRONT LOWER ARM COMP. (RIGHT)	1	1	
63	90381-16N51	.BUSH, SOLID	2	2	



FIG. 21 STEERING

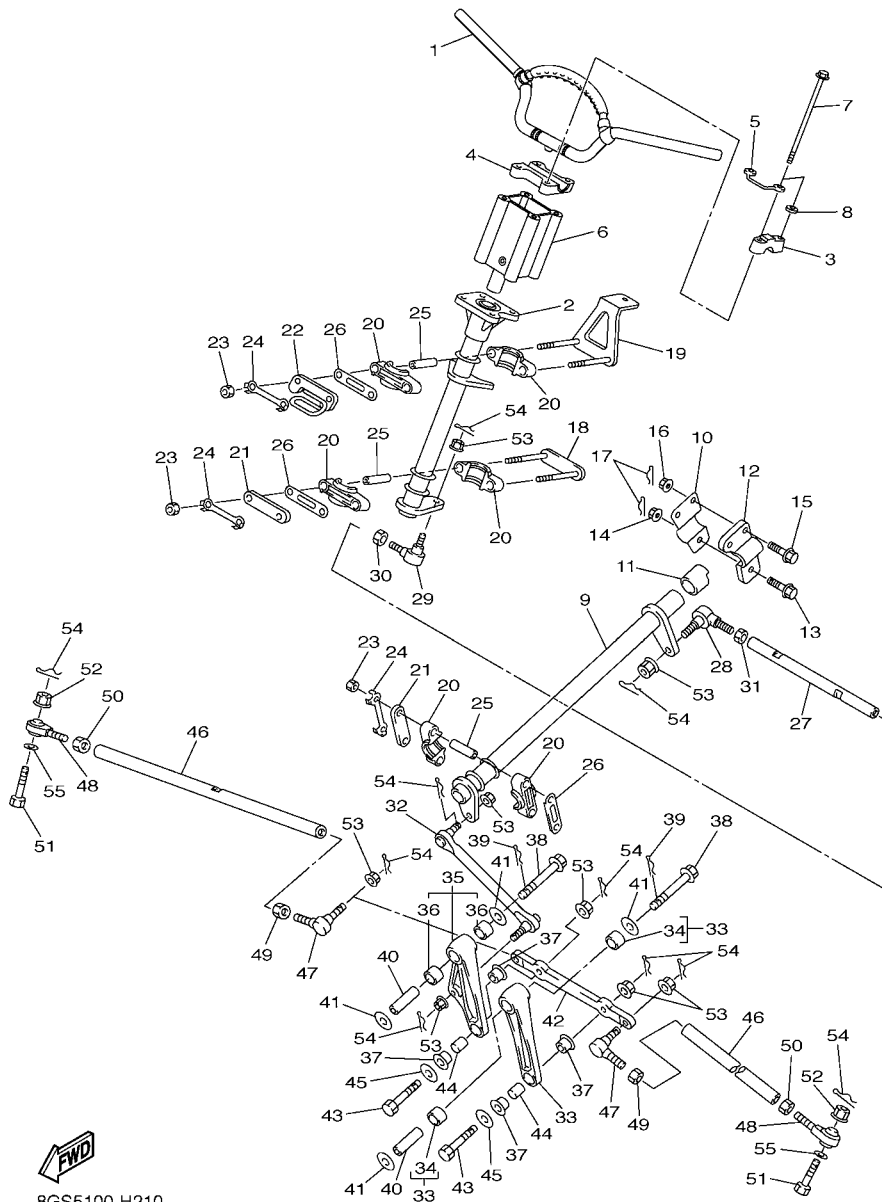
REF. NO.	PART NO.	DESCRIPTION	8GS5	8GS6	REMARKS
1	8FN-26110-00	HANDLE COMP.	1	1	
2	8FA-23813-01	COLUMN, STEERING 2	1	1	
3	8K1-23814-00	HOLDER, HANDLE	2	2	
4	8ED-23442-00	HOLDER, HANDLE LOWER	1	1	
5	8DF-23857-00	HOLDER	1	1	
6	8FK-2381B-00	JOINT	1	1	
7	90105-08072	BOLT, FLANGE	4	4	
8	90201-08020	WASHER, PLATE	2	2	
9	8FA-23811-00	COLUMN, STEERING	1	1	
10	8FA-23818-02	COVER, STEERING	1	1	
11	8FA-23873-00	BEARING, STEERING UPPER	1	1	
12	8FN-23867-00	HOLDER 2	1	1	
13	90105-10549	BOLT, FLANGE	1	1	
14	95602-10200	NUT, U FLANGE	1	1	
15	90105-08552	BOLT, FLANGE	2	2	
16	95602-08200	NUT, SELF-LOCKING	2	2	
17	90468-12006	CLIP	3	3	
18	8FA-23872-00	HOLDER, BEARING	1	1	
19	8FN-2376H-00	HOLDER, BEARING	1	1	
20	8FA-23812-00	BEARING, STEERING	6	6	
21	8FA-23867-00	HOLDER 2	2	2	
22	8FN-23872-00	HOLDER, BEARING	1	1	
23	95312-08600	NUT	6	6	
24	1UY-23894-01	WASHER, LOCK 1	3	3	
25	8HF-2412G-00	COLLAR	6	6	
26	8FA-23843-00	WASHER, PLAIN	3	3	
27	8FN-23828-00	ROD, STEERING	1	1	



8GS5100-H210

FIG. 21 STEERING

REF. NO.	PART NO.	DESCRIPTION	8GS5	8GS6	REMARKS
28	8CR-23847-00	JOINT, UNIVERSAL 3	1	1	
29	8CR-23845-10	JOINT, UNIVERSAL 2	1	1	
30	95307-10700	NUT	1	1	
31	90170-10186	NUT	1	1	(L.H. THREAD)
32	8FA-23821-00	ROD, STEERING RELAY	1	1	
33	8FN-2389K-00	ARM PIVOT ASSY	1	1	
34	90383-17001	.BUSH, FORMED	2	2	
35	8FN-2389M-00	PIVOT ARM ASSY 2	1	1	
36	93317-41785	.BEARING	2	2	
37	90381-14001	BUSH, SOLID	4	4	
38	90105-12017	BOLT, FLANGE	2	2	
39	8FA-2384N-00	CLIP, RING	2	2	
40	8FA-2412G-00	COLLAR	2	2	
41	90201-121U3	WASHER, PLATE	4	4	
42	8FN-23826-00	ARM, IDLER	1	1	
43	90102-10044	BOLT, WITH HOLE	2	2	
44	90387-10008	COLLAR	2	2	
45	90201-10742	WASHER, PLATE	2	2	
46	8FN-23831-00	ROD, TIE	2	2	
47	8CR-23845-10	JOINT, UNIVERSAL 2	2	2	
48	8FA-23847-00	JOINT, UNIVERSAL 3	2	2	
49	95307-10700	NUT	2	2	
50	90170-10186	NUT	2	2	(L.H. THREAD)
51	90102-10044	BOLT, WITH HOLE	2	2	
52	95702-10300	NUT, NYLON	2	2	
53	95702-10500	NUT, WITH WASHER	8	8	
54	91402-20020	PIN, COTTER	10	10	

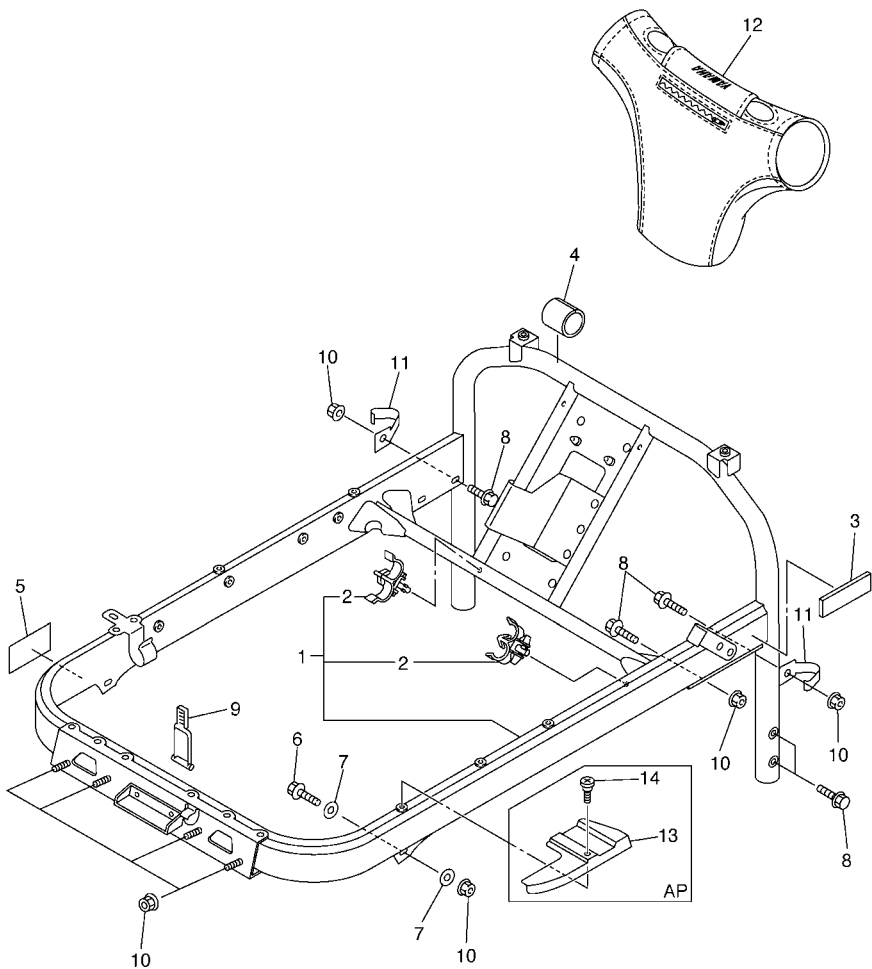


8GS5100-H210

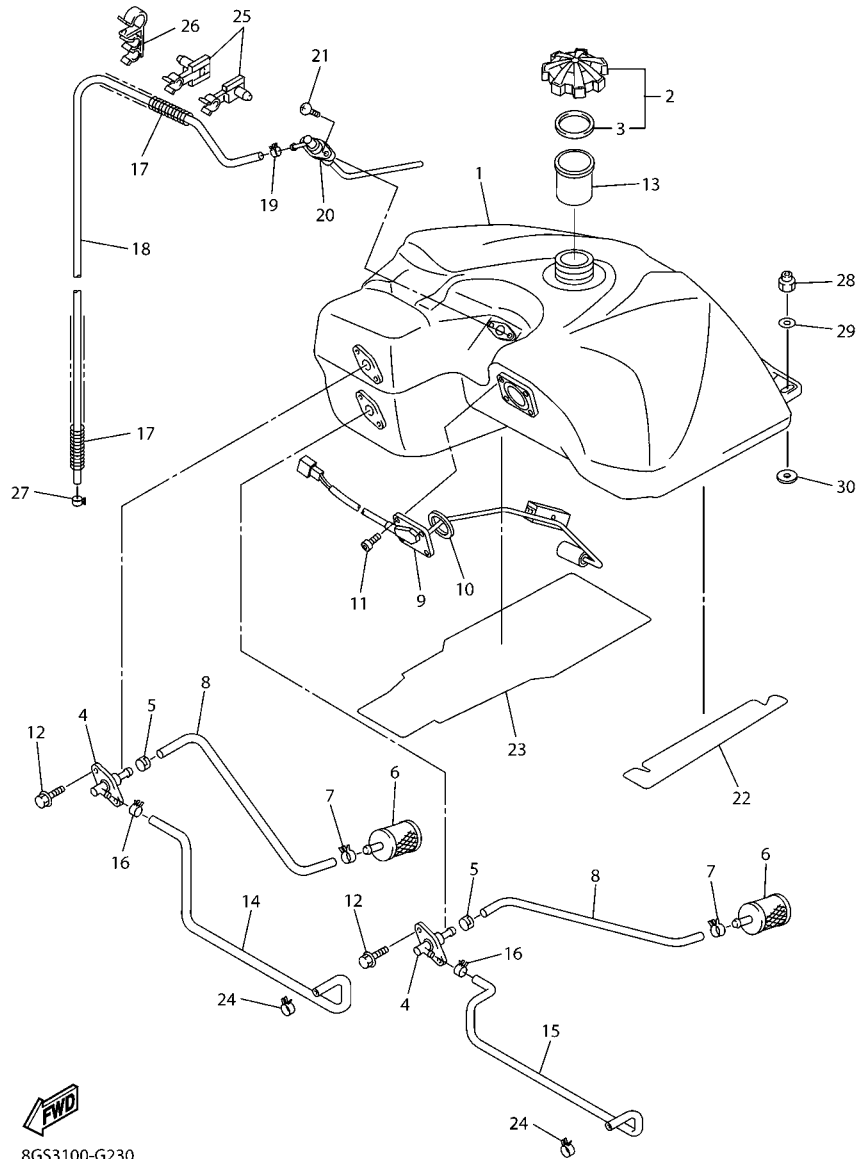


**FIG. 22 STEERING GATE**

REF. NO.	PART NO.	DESCRIPTION	8GS5	8GS6		REMARKS
1	8GS-23870-00	STEERING GATE COMP.	1	1		
2	90464-11007	.CLAMP	2	2		
3	8FN-24181-00	DAMPER, LOCATING 1	2	2		
4	8FN-24182-00	DAMPER, LOCATING 2	1	1		
5	8FA-2389C-E0	LABEL, CAUTION	1			
	8FA-2389C-S0	LABEL, CAUTION		1		UR FOR EUR,RUS
	8FA-2389C-J0	LABEL, CAUTION		1		UR FOR JPN
6	90105-081A7	BOLT, FLANGE	2	2		
7	90201-08326	WASHER, PLATE	4	4		
8	95822-08020	BOLT, FLANGE	7	7		
9	8FA-2389E-00	LATCH	1	1		
10	95602-08200	NUT, SELF-LOCKING	9	9		
11	90462-10022	CLAMP	2	2		
12	8FN-23815-00	PAD, STEERING	1	1		
13	8ES-14146-00	PLATE	1	1		AP
14	90150-06015	SCREW, ROUND HEAD	1	1		AP



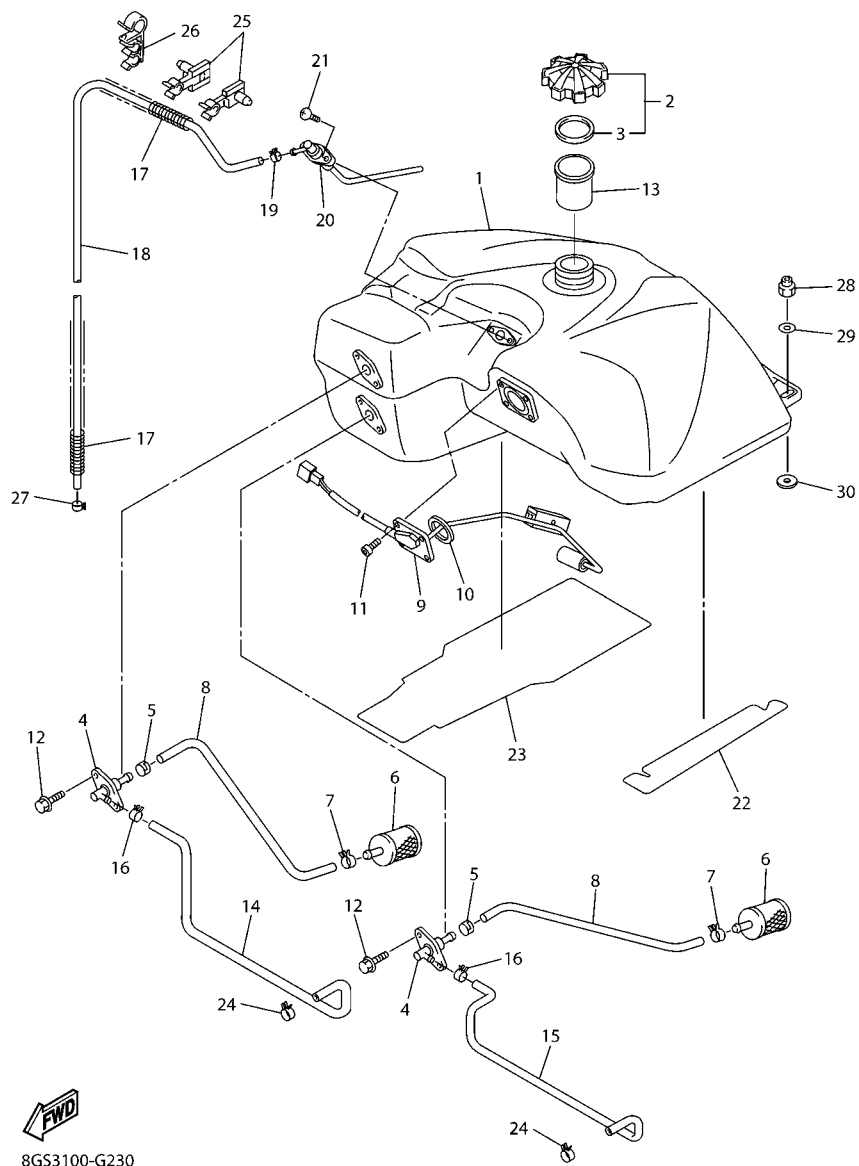
8FN1100-E220



8GS3100-G230

FIG. 23 FUEL TANK

REF. NO.	PART NO.	DESCRIPTION	8GS5	8GS6	REMARKS
1	8FN-24111-10	TANK, FUEL	1		
	8FN-24111-01	TANK, FUEL		1	
2	8FG-24610-00	CAP ASSY	1	1	
3	8FG-24641-00	.GASKET, CAP 1	1	1	
4	8CR-24301-00	SUCTION PIPE COMP. 1	2	2	
5	90468-04092	CLIP	2	2	
6	8H5-24560-00	FILTER ASSY	2	2	
7	90467-11032	CLIP	2	2	
8	8FA-24335-00	PIPE, SUCTION 1	2	2	
9	8GS-85752-00	SENDER UNIT ASSY, FUEL METER	1	1	
10	93210-41041	O-RING	1	1	
11	98902-05008	SCREW, BIND	4	4	
12	90105-060A6	BOLT, FLANGE	4	4	
13	8FN-24114-00	TUBE, FILLER	1	1	
14	8GS-24311-00	PIPE, FUEL 1	1		
	8FN-24311-00	PIPE, FUEL 1		1	
15	8GS-24311-10	PIPE, FUEL 1	1		
	8FN-24311-10	PIPE, FUEL 1		1	
16	90467-11032	CLIP	2	2	
17	90501-08668	SPRING, COMPRESSION	2	2	
18	91A20-05130	TUBE, FLEXIBLE VINYL	1	1	
19	90467-09026	CLIP	1	1	
20	8FN-2418A-00	BREATHER COMP.	1	1	
21	90149-06330	SCREW	2	2	
22	8GS-24181-00	DAMPER, LOCATING 1	1		
23	8GS-24182-00	DAMPER, LOCATING 2	1		
24	90467-11032	CLIP	2	2	



8GS3100-G230

FIG. 23 FUEL TANK

REF. NO.	PART NO.	DESCRIPTION	8GS5	8GS6		REMARKS
25	90464-09015	CLAMP	2	2		
26	90464-16010	CLAMP	1	1		
27	90467-09026	CLIP	1	1		
28	95702-08300	NUT, NYLON	2	2		
29	90201-08053	WASHER, PLATE	2	2		
30	90201-08075	WASHER, PLATE	2			

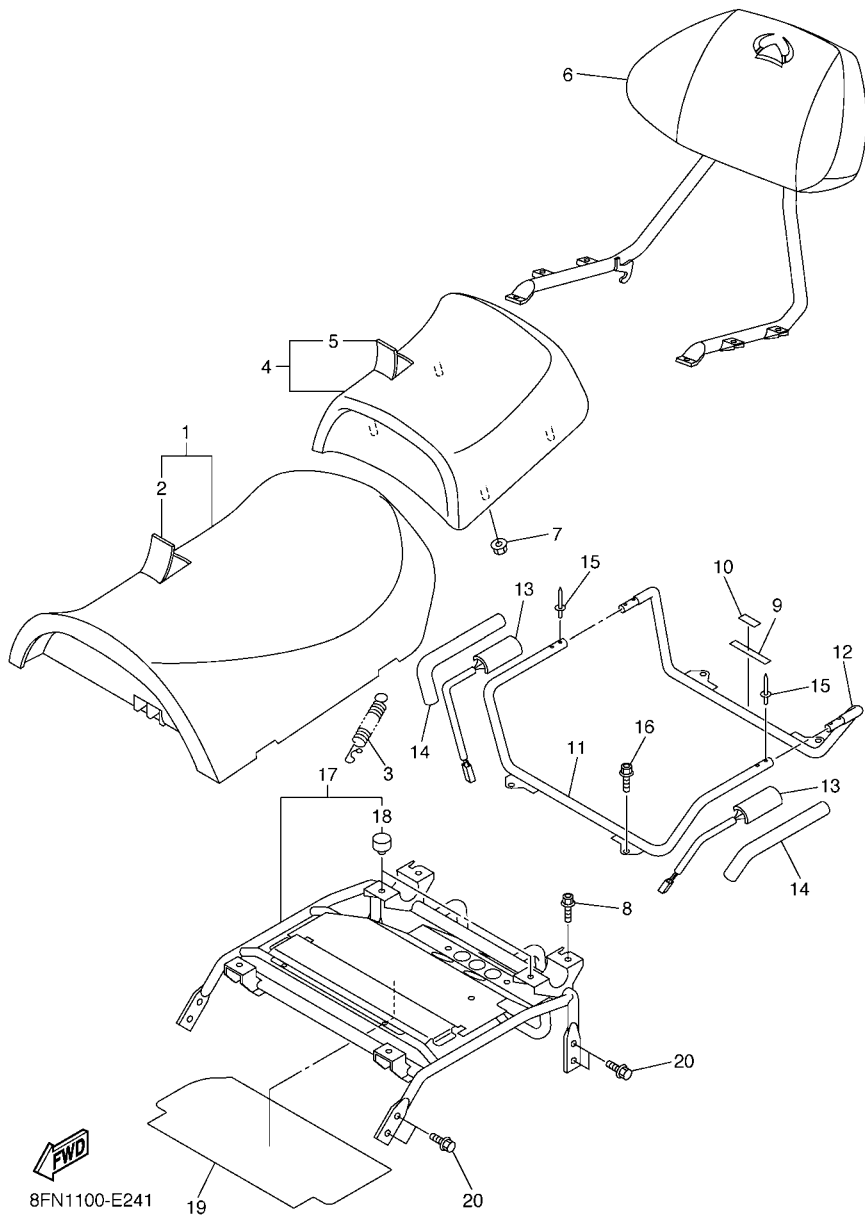
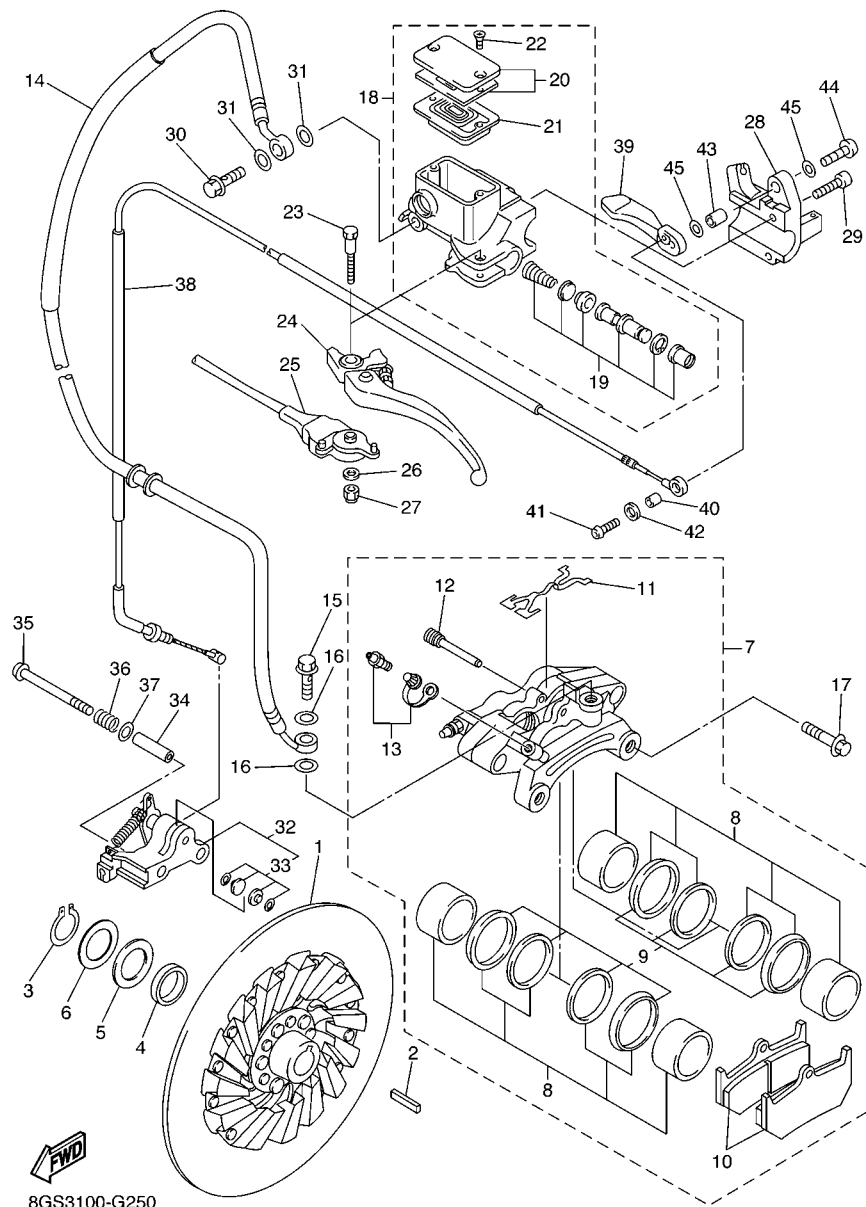


FIG. 24 SEAT

REF. NO.	PART NO.	DESCRIPTION	8GS5	8GS6		REMARKS
1	8FN-24710-02	SINGLE SEAT ASSY	1	1		
2	8FN-2470F-02	.SEAT COVER COMP.	1	1		
3	89A-77159-00	CLAMP, ROD	1	1		
4	8FN-24750-01	TANDEM SEAT ASSY	1	1		
5	8FN-2470H-01	.SEAT COVER COMP. ,2	1	1		
6	8FN-24790-00	SEAT BACK ASSY	1	1		
7	95702-06500	NUT, FLANGE	4	4		
8	90105-10151	BOLT, FLANGE	2	2		
9	8FN-24897-00	EMBLEM	1			
	8FN-24897-10	EMBLEM		1		
10	3AC-24877-C0	LABEL, CAUTION	1			JAPANESE
11	8FN-2474A-00	ASSIST, GRIP	1	1		
12	8FN-2474W-00	ASSIST,GRIP 2	1	1		
13	8GS-2474B-00	ASSIST GRIP WARMER ASSY 1	2	2		
14	8ET-24796-00	COVER	2	2		
15	90267-47186	RIVET, BLIND (4.7X16.4 BLACK)	6	6		
16	90105-10151	BOLT, FLANGE	2	2		
17	8FN-2474H-00	BRACKET, ASSIST GRIP 1	1	1		
18	8FA-27114-00	.STOPPER	2	2		
19	8FN-2476U-00	PROTECTOR,1	1	1		
20	95822-08014	BOLT, FLANGE	8	8		



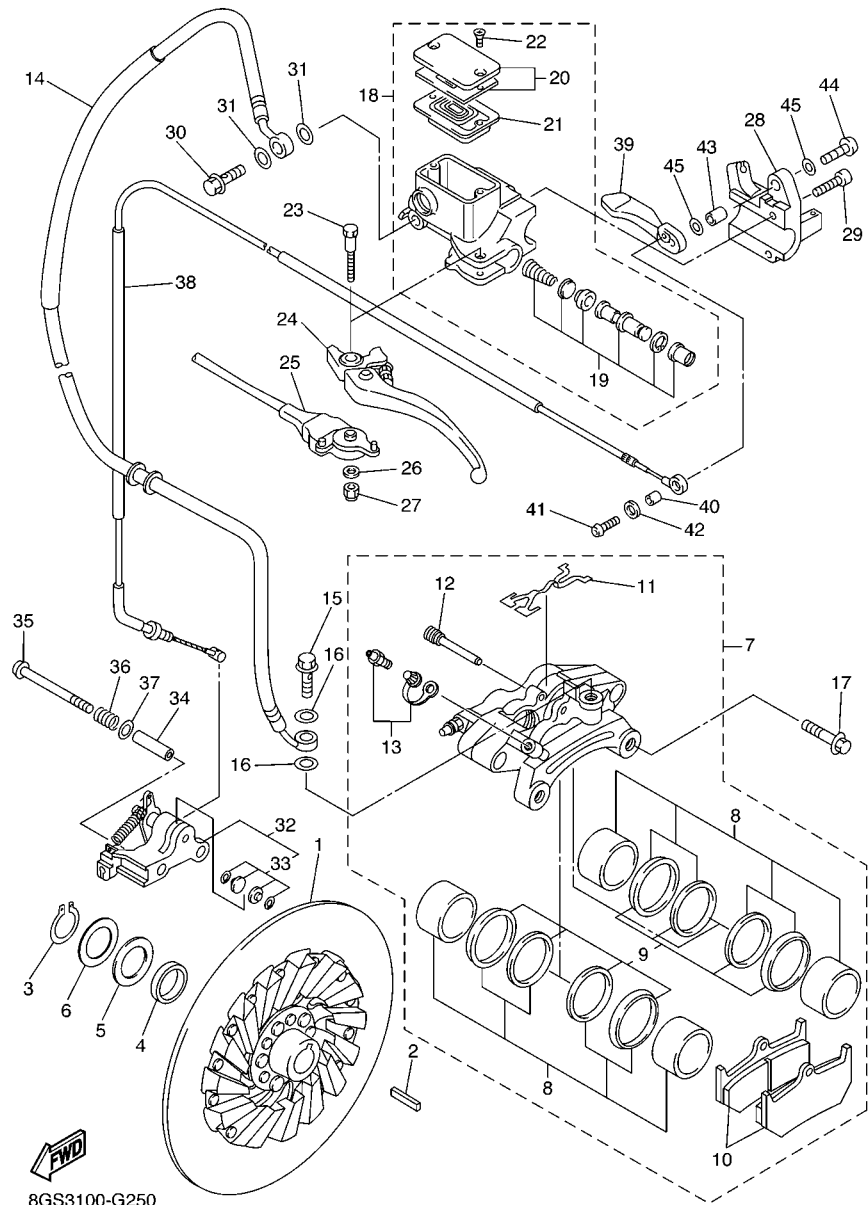
8GS3100-G250



FIG. 25 BRAKE

REF. NO.	PART NO.	DESCRIPTION	8GS5	8GS6	REMARKS
1	8FU-2581T-00	DISK BRAKE ASSY	1	1	
2	90282-07002	KEY, STRAIGHT	1	1	
3	99009-24400	CIRCLIP	1	1	
4	90387-25011	COLLAR	1	1	
5	90201-25527	WASHER, PLATE (T1.0)	2	2	UN
6	90201-252F1	WASHER, PLATE (T0.5)	2	2	UN
7	8FU-2580T-01	CALIPER ASSY (LEFT)	1	1	
8	8FU-W0057-00	.PISTON ASSY, CALIPER	2	2	
9	3JD-W0047-10	..CALIPER SEAL KIT	1	1	
10	8FU-W0046-01	.BRAKE PAD KIT 2	1	1	
11	8FU-25919-00	.SUPPORT, PAD	1	1	
12	8FU-25924-00	.PIN, PAD	1	1	
13	8CR-W0048-00	.BLEED SCREW KIT	2	2	
14	8GS-25872-01	HOSE, BRAKE 1	1	1	
15	90401-10015	BOLT, UNION	1	1	
16	90201-10118	WASHER, PLATE	2	2	
17	90105-10096	BOLT, FLANGE	2	2	
18	8EN-W2587-00	MASTER CYLINDER SUB ASSY	1	1	
	8EN-W2587-10	MASTER CYLINDER SUB ASSY	1		FOR JPN
19	8CR-W0041-00	.CYLINDER KIT, MASTER	1	1	
20	8CR-W2585-00	.RESERVOIR CAP SET	1	1	
	3GM-W2585-21	.RESERVOIR CAP SET	1		FOR JPN
21	55U-25854-00	.GASKET, DIAPHRAGM	1	1	
22	98706-04012	.SCREW, FLAT HEAD	2	2	
23	8CR-2589F-00	BOLT, LEVER	1	1	
24	8CR-83912-00	LEVER 1	1	1	
	8DN-83912-00	LEVER 1	1	1	AP



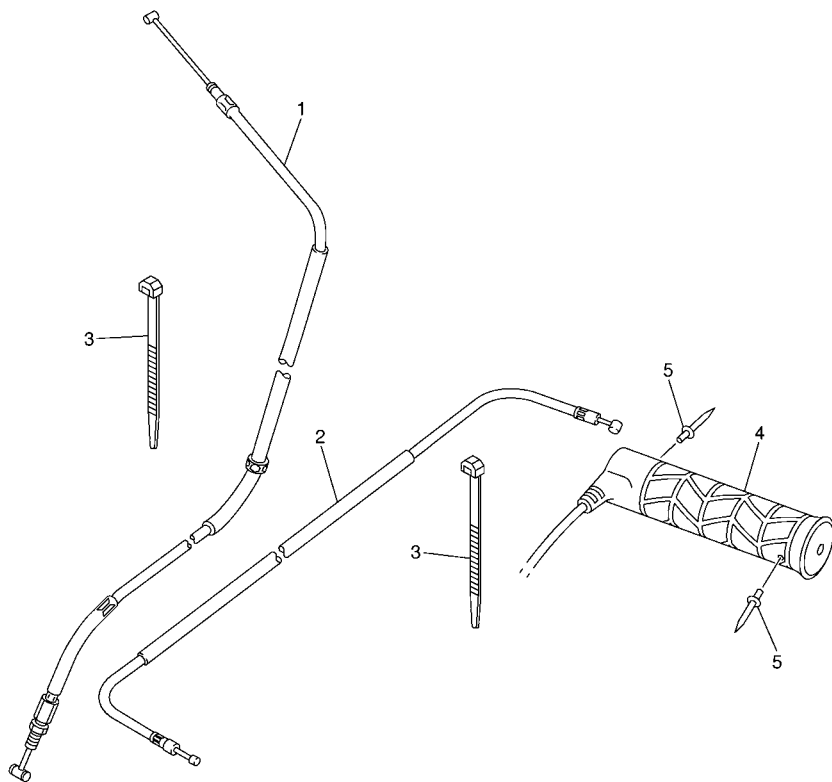


8GS3100-G250

FIG. 25 BRAKE

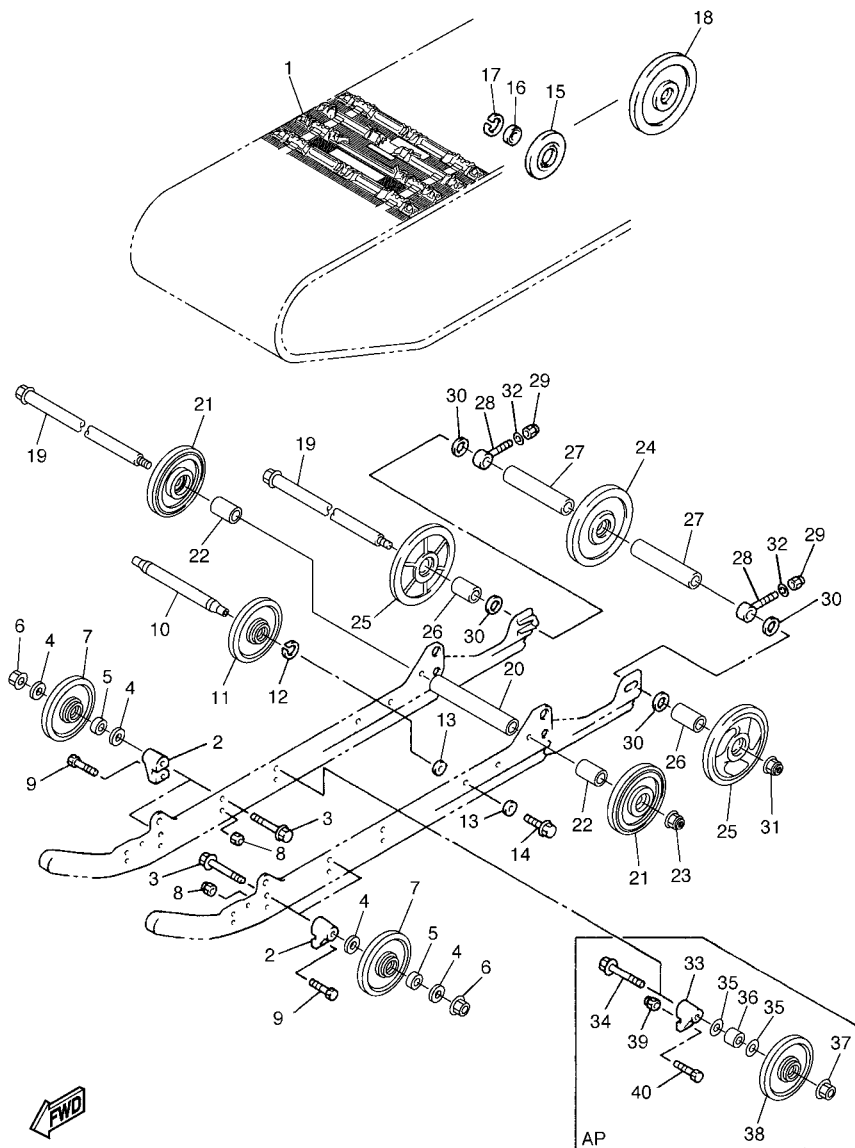
REF. NO.	PART NO.	DESCRIPTION	8GS5	8GS6	REMARKS
25	8CR-82530-01	STOP SWITCH ASSY	1	1	
26	8CR-8398X-00	WASHER, PLATE	1	1	
27	95707-05300	NUT, FLANGE	1	1	
28	8FA-25867-00	BRACKET, MASTER CYLINDER	1	1	
29	91316-06022	BOLT	2	2	
30	90401-10015	BOLT, UNION	1	1	
31	90201-10118	WASHER, PLATE	2	2	
32	8FU-25970-01	PARKING BRAKE COMP.	1	1	
33	8FA-W0045-00	.PARKING BRAKE PAD KIT	1	1	
34	90387-06058	COLLAR	2	2	
35	90111-06042	BOLT,HEX. SOCKET BUTTON	2	2	
36	90501-120A0	SPRING, COMPRESSION	2	2	
37	90201-12161	WASHER, PLATE	2	2	
38	8FN-26351-10	CABLE, BRAKE	1	1	
39	8FA-83922-00	LEVER 2	1	1	
40	90387-06043	COLLAR	1	1	
41	92017-06014	BOLT, BUTTON HEAD	1	1	
42	90201-06050	WASHER, PLATE	1	1	
43	90387-081M9	COLLAR	1	1	
44	90111-08054	BOLT,HEX. SOCKET BUTTON	1	1	
45	90201-08403	WASHER, PLATE	2	2	

**FIG. 26 CONTROL CABLE**



8FN1100-E260

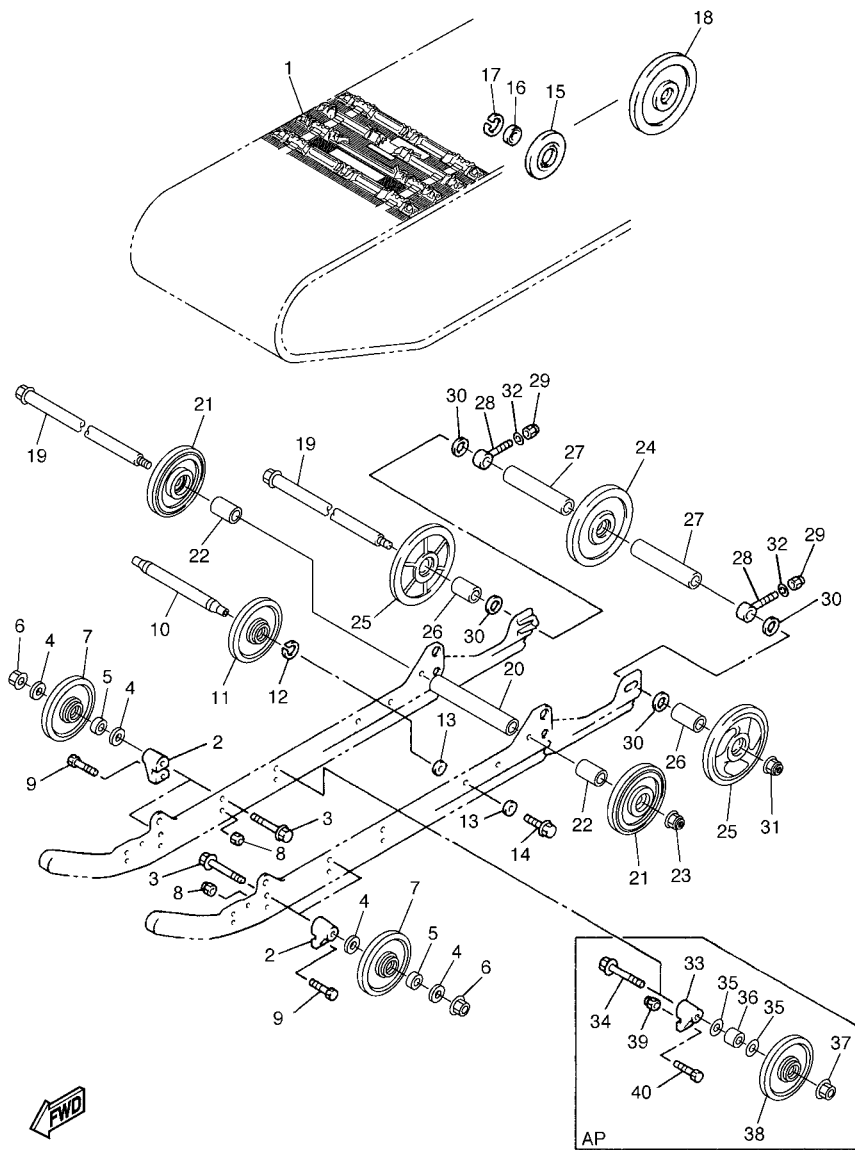
REF. NO.	PART NO.	DESCRIPTION	8CS5	8CS6			REMARKS
1	8FN-26311-00	CABLE, THROTTLE 1	1	1			
2	8FN-26330-00	STARTER CABLE ASSY	1	1			
3	90464-13073	CLAMP	2	2			
4	8DM-26240-01	GRIP ASSY	2	2			
5	90267-48014	RIVET, BLIND (4.8X15.1 BLACK)	4	4			
-----							
-----							
-----							
-----							
-----							
-----							
-----							
-----							
-----							



8FN1100-E270

FIG. 27 TRACK SUSPENSION 1

REF. NO.	PART NO.	DESCRIPTION	8GS5	8GS6	REMARKS
1	8FN-47110-00	TRACK ASSY	1	1	
2	8CM-47419-10	BRACKET 7	4	4	
3	95817-10080	BOLT, FLANGE	4	4	
4	90201-100S0	WASHER, PLATE	8	8	
5	90387-10031	COLLAR	4	4	
6	95604-10200	NUT, SELF-LOCKING	4	4	
7	8ES-47310-00	SUSPENSION WHEEL ASSY	4	4	
8	95607-08200	NUT, SELF-LOCKING	4	4	
9	90101-08774	BOLT	4	4	
10	8FN-47486-00	SHAFT 4	1	1	
11	8ES-47310-00	SUSPENSION WHEEL ASSY	2	2	
12	99009-25400	CIRCLIP	2	2	
13	90201-100L3	WASHER, PLATE	4	4	
14	90105-10433	BOLT, FLANGE	2	2	
15	8AC-47320-00	SUSPENSION WHEEL COMP.	2	2	
16	93306-00444	BEARING	2	2	
17	99009-42500	CIRCLIP	2	2	
18	8AC-47550-00	GUIDE WHEEL ASSY	2	2	
19	83R-47520-10	REAR AXLE COMP.	2	2	
20	83R-47469-00	COLLAR 1	1	1	
21	8FM-47310-00	SUSPENSION WHEEL ASSY	2	2	
22	90387-203H0	COLLAR	2	2	
23	95607-14200	NUT, SELF-LOCKING	1	1	
24	8CR-47550-10	GUIDE WHEEL ASSY	1	1	
25	8EK-47550-10	GUIDE WHEEL ASSY	2	2	
26	90387-20022	COLLAR	2	2	
27	90387-20023	COLLAR	2	2	



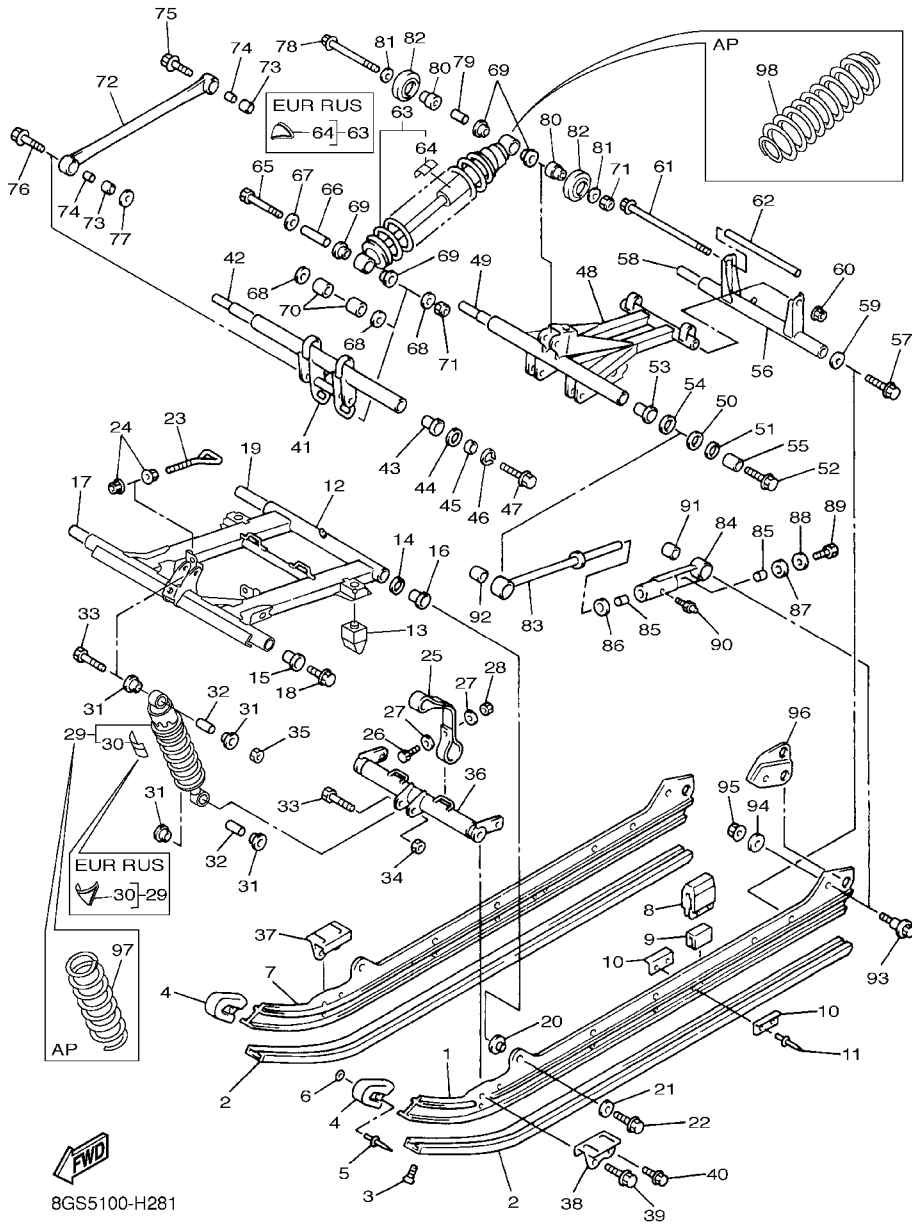
8FN1100-E270

FIG. 27 TRACK SUSPENSION 1

REF. NO.	PART NO.	DESCRIPTION	8CS5	8CS6		REMARKS
28	8DM-47479-00	COLLAR 3	2	2		
29	95707-10300	NUT, FLANGE	2	2		
30	90201-205R6	WASHER, PLATE	4	4		
31	95607-14200	NUT, SELF-LOCKING	1	1		
32	92907-10600	WASHER, PLATE	2	2		
33	8CM-47419-10	BRACKET 7	2	2		AP
34	95817-10080	BOLT, FLANGE	2	2		AP
35	90201-100S0	WASHER, PLATE	4	4		AP
36	90387-10031	COLLAR	2	2		AP
37	95604-10200	NUT, SELF-LOCKING	2	2		AP
38	8ES-47310-00	SUSPENSION WHEEL ASSY	2	2		AP
39	95607-08200	NUT, SELF-LOCKING	2	2		AP
40	90101-08774	BOLT	2	2		AP

FIG. 28 TRACK SUSPENSION 2

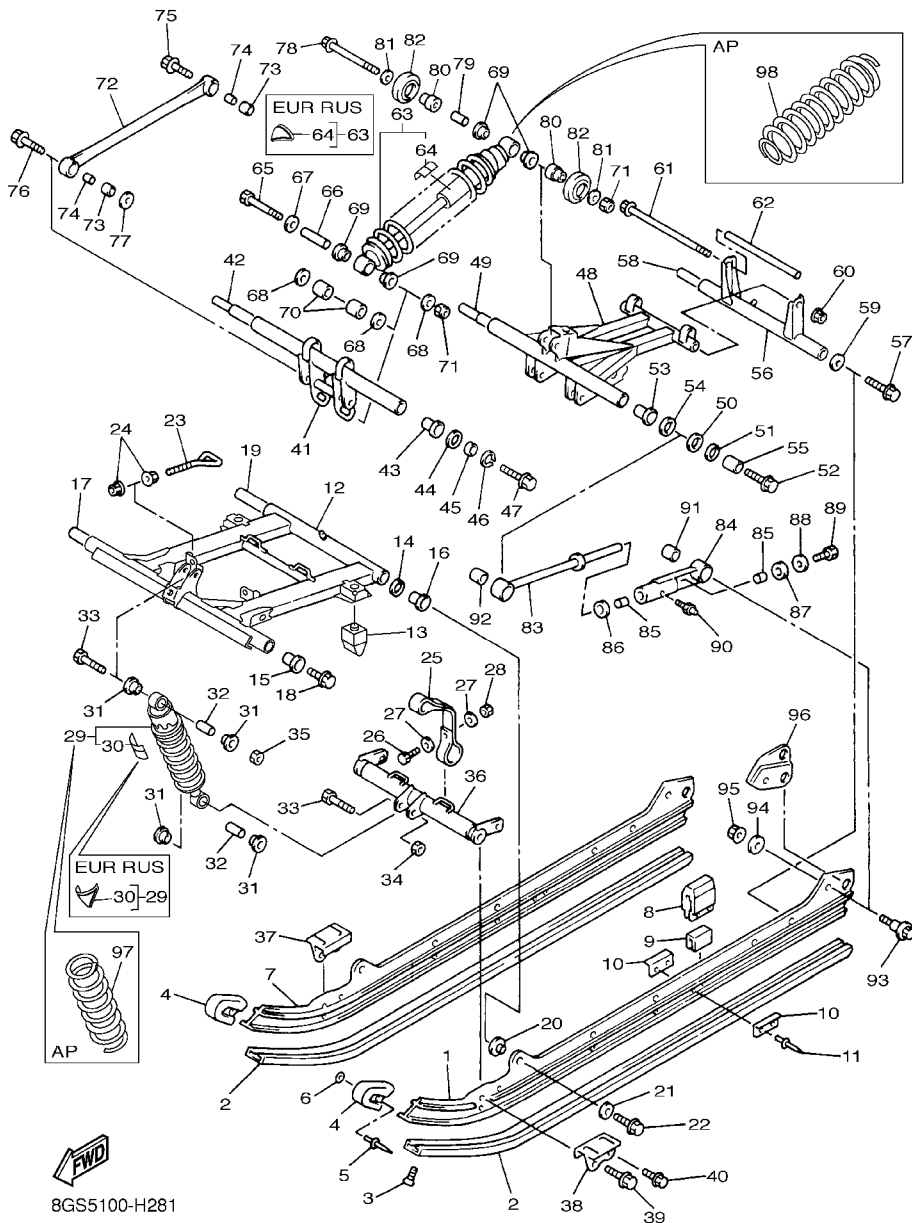
REF. NO.	PART NO.	DESCRIPTION	8GS5	8GS6	REMARKS
1	8AC-47411-10	FRAME, SLIDING 1	1	1	
2	8AC-47421-00	RUNNER, SLIDING 1	2	2	
3	90151-06010	SCREW, COUNTERSUNK	2	2	
4	8ED-47422-00	RUNNER, SLIDING 2	2	2	
5	90267-48194	RIVET, BLIND (4.8X28 SILVER)	2	2	
6	90201-047R8	WASHER, PLATE	2	2	
7	8AC-47414-10	FRAME, SLIDING 4	1	1	
8	8AC-47457-00	DAMPER 2	2	2	
9	8AC-47341-00	SPACER	2	2	
10	8AX-47458-00	PLATE, DAMPER	4	4	
11	90267-48199	RIVET, BLIND (4.8X28.3)	4	4	
12	8GS-47331-00	ARM, PIVOT 1	1	1	
13	8FN-47456-00	DAMPER 1	2	2	
14	90201-210U0	WASHER, PLATE	2	2	
15	90386-25002	BUSH	2	2	
16	90381-19111	BUSH, SOLID	2	2	
17	8GS-47465-00	SHAFT 1	1	1	
18	90105-103A1	BOLT, FLANGE	2	2	
19	83R-47485-02	SHAFT 3	1	1	
20	90387-105G6	COLLAR	2	2	
21	90201-100L3	WASHER, PLATE	2	2	
22	90105-10433	BOLT, FLANGE	2	2	
23	8CR-47448-00	HOOK 3	2	2	
24	95707-08500	NUT, FLANGE	4	4	
25	8CV-47495-00	STOPPER 1	2	2	
26	97007-06025	BOLT	4	4	
27	90201-06747	WASHER, PLATE	8	8	



8GS5100-H281

FIG. 28 TRACK SUSPENSION 2

REF. NO.	PART NO.	DESCRIPTION	8GS5	8GS6	REMARKS
28	95707-06300	NUT, NYLON	4	4	
29	8FN-47481-30	SHOCK ABSORBER 2	1		
	8FN-47481-40	SHOCK ABSORBER 2		1	UR FOR EUR,RUS
	8FN-47481-50	SHOCK ABSORBER 2		1	UR FOR JPN
30	4AA-22259-60	.LABEL, WARNING	1		
	4AA-22259-40	.LABEL, WARNING		1	UR FOR EUR,RUS
	4AA-22259-50	.LABEL, WARNING		1	UR FOR JPN
31	90381-14101	BUSH, SOLID	4	4	
32	90387-105G5	COLLAR	2	2	
33	90101-10738	BOLT	2	2	
34	90185-10110	NUT, SELF-LOCKING	1	1	
35	95607-10100	NUT, U	1	1	
36	8AC-47418-00	BRACKET 4	1	1	
37	8DF-47463-01	BRACKET 5	1	1	
38	8DF-47464-01	BRACKET 6	1	1	
39	90105-10433	BOLT, FLANGE	2	2	
40	90105-08450	BOLT, FLANGE	2	2	
41	8AC-47416-01	BRACKET 2	1	1	
42	8FN-47488-00	SHAFT 6	1	1	
43	90381-22099	BUSH, SOLID	2	2	
44	90201-207J5	WASHER, PLATE	2	2	
45	90387-2004V	COLLAR	2	2	
46	99009-20400	CIRCLIP	2	2	
47	90105-103A1	BOLT, FLANGE	2	2	
48	8GS-47332-00	ARM, PIVOT 2	1	1	
49	8AC-47475-00	SHAFT 2	1	1	
50	90201-266L1	WASHER, PLATE	2	2	



8GS5100-H281

FIG. 28 TRACK SUSPENSION 2

REF. NO.	PART NO.	DESCRIPTION	8GS5	8GS6	REMARKS
51	90201-250T6	WASHER, PLATE	2	2	
52	90105-103A1	BOLT, FLANGE	2	2	
53	90381-28108	BUSH, SOLID	2	2	
54	90201-286K9	WASHER, PLATE (T1.0)	2	2	
55	90387-2515E	COLLAR	2	2	
56	8AC-47417-00	BRACKET 3	1	1	
57	90105-10433	BOLT, FLANGE	2	2	
58	83R-47485-02	SHAFT 3	1	1	
59	90201-10136	WASHER, PLATE	2	2	
60	95607-08200	NUT, SELF-LOCKING	1	1	
61	95827-08220	BOLT, FLANGE	1	1	
62	90387-083G6	COLLAR	1	1	
63	8FN-47480-30	SHOCK ABSORBER	1		
	8FN-47480-40	SHOCK ABSORBER	1		UR FOR EUR,RUS
	8FN-47480-50	SHOCK ABSORBER	1		UR FOR JPN
64	4AA-22259-60	.LABEL, WARNING	1		
	4AA-22259-40	.LABEL, WARNING	1		UR FOR EUR,RUS
	4AA-22259-50	.LABEL, WARNING	1		UR FOR JPN
65	8AC-4631K-00	BOLT, ADJUSTING	1	1	
66	90387-1009S	COLLAR	1	1	
67	90201-103U4	WASHER, PLATE	1	1	
68	90201-100U1	WASHER, PLATE	3	3	
69	90381-14101	BUSH, SOLID	4	4	
70	90387-1404R	COLLAR	2	2	
71	95607-10100	NUT, U	2	2	
72	8CR-47494-01	ROD, RELAY	2	2	
73	90381-14109	BUSH, SOLID	4	4	

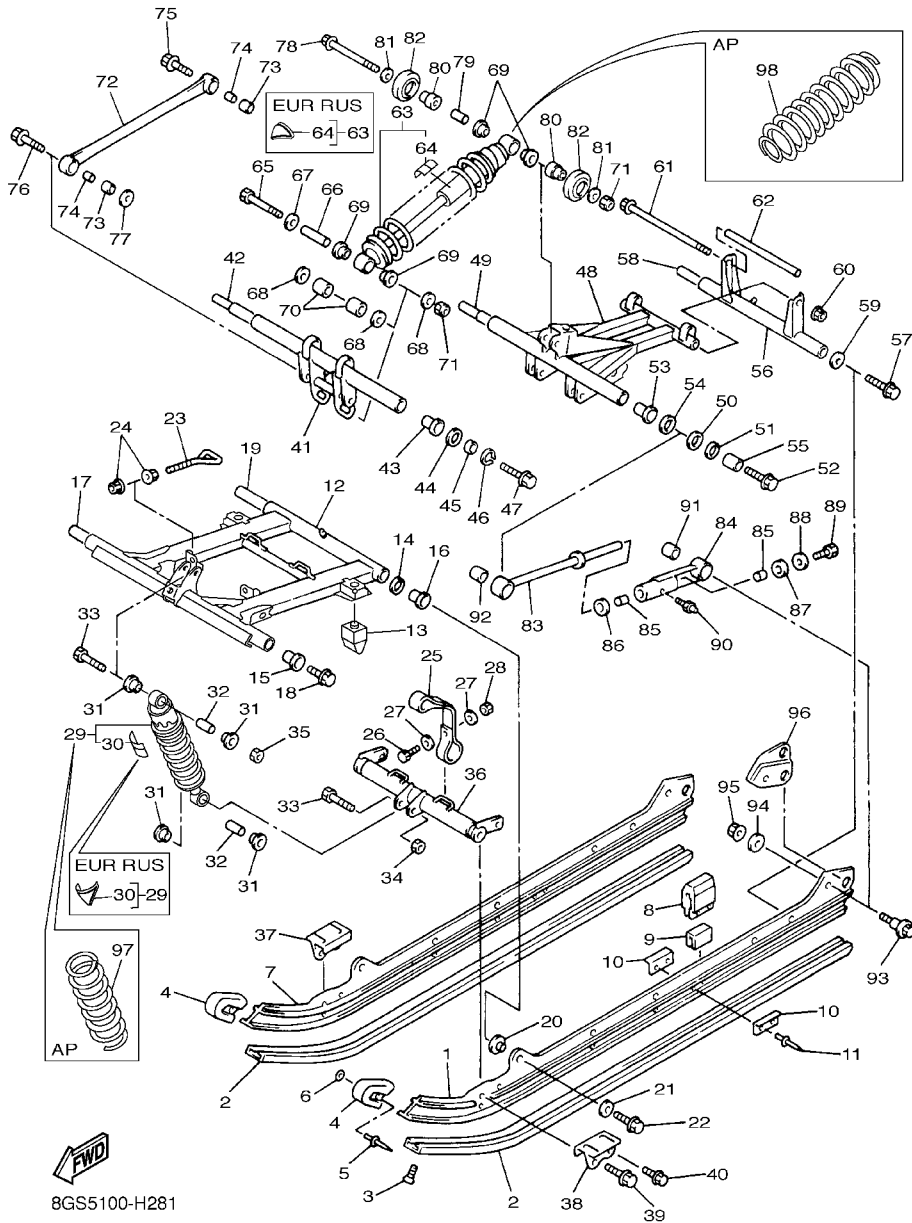
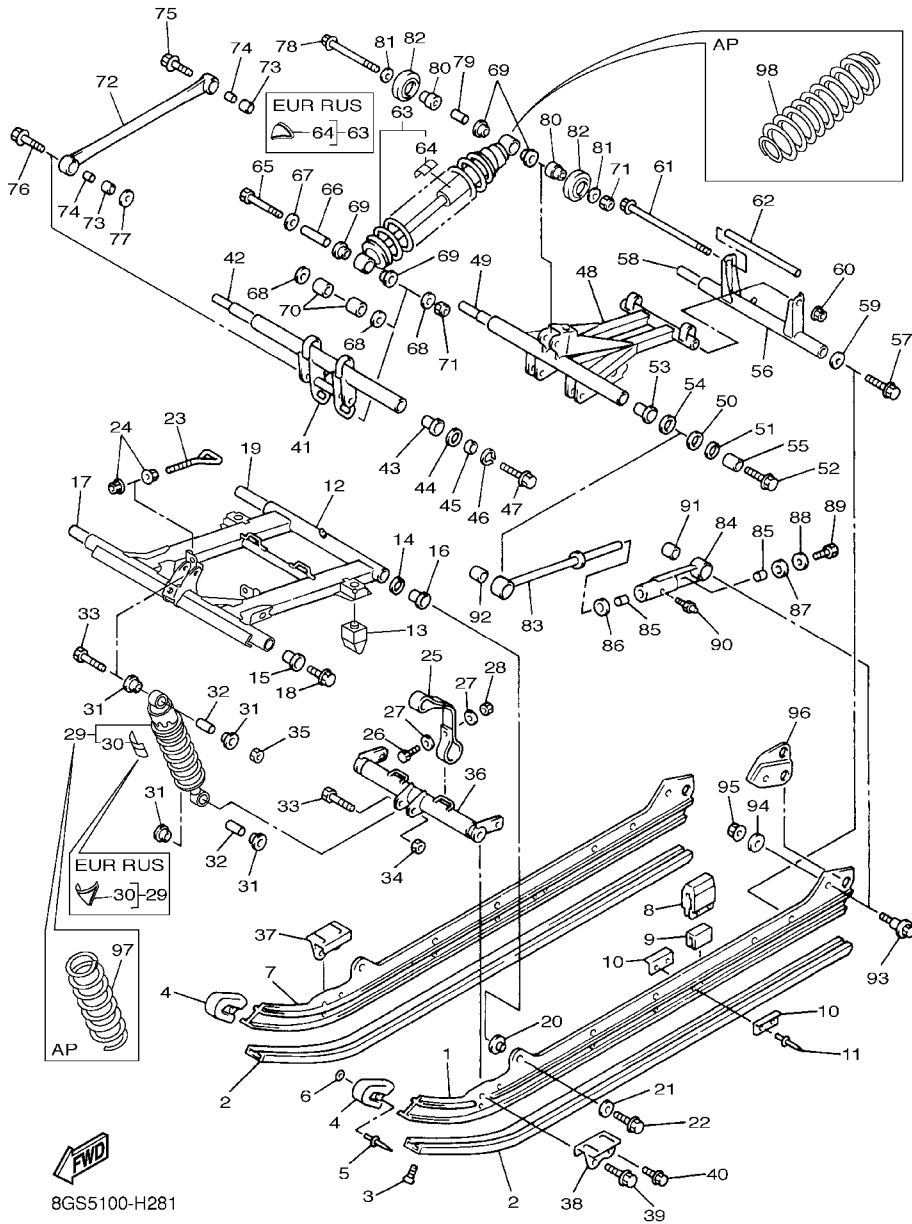


FIG. 28 TRACK SUSPENSION 2

REF. NO.	PART NO.	DESCRIPTION	8GS5	8GS6	REMARKS
74	90387-100X3	COLLAR	4	4	
75	90105-10739	BOLT, FLANGE	2	2	
76	90105-10436	BOLT, FLANGE	2	2	
77	90201-100U1	WASHER, PLATE	2	2	
78	90105-10105	BOLT, FLANGE	1	1	
79	90387-105G5	COLLAR	1	1	
80	8AC-47366-00	COLLAR 2	2	2	
81	90201-10136	WASHER, PLATE	2	2	
82	8AC-47310-10	SUSPENSION WHEEL ASSY	2	2	
83	8AC-4745A-10	ROD, CONTROL 1	2	2	
84	8CR-4745B-00	ROD, CONTROL 2	2	2	
85	90384-16251	BUSH, BIMETAL FORMED	4	4	
86	90202-16229	WASHER, PLATE	2	2	
87	90202-16232	WASHER, PLATE	2	2	
88	90201-106F2	WASHER, PLATE	2	2	
89	97027-10025	BOLT, HEXAGON	2	2	
90	93700-06004	NIPPLE, GREASE	2	2	
91	90380-22232	BUSH, SOLID	2	2	
92	90380-28235	BUSH, SOLID	2	2	
93	8DF-47367-00	SCREW, REAR PIVOT	2	2	
94	90201-101U2	WASHER, PLATE	2	2	
95	95607-10200	NUT, U FLANGE	2	2	
96	8AC-47349-00	BRACKET, ARM PIVOT	2	2	
97	8FN-47336-00	SPRING 1 (K=14.7N/MM)	1	1	AP
	8FN-47336-10	SPRING 1 (K=17.7N/MM)	1	1	AP
	8FN-47336-20	SPRING 1 (K=20.6N/MM)	1	1	AP
98	8FN-47489-00	SPRING 1 (K=63.7N/MM)	1	1	AP



8GS5100-H281



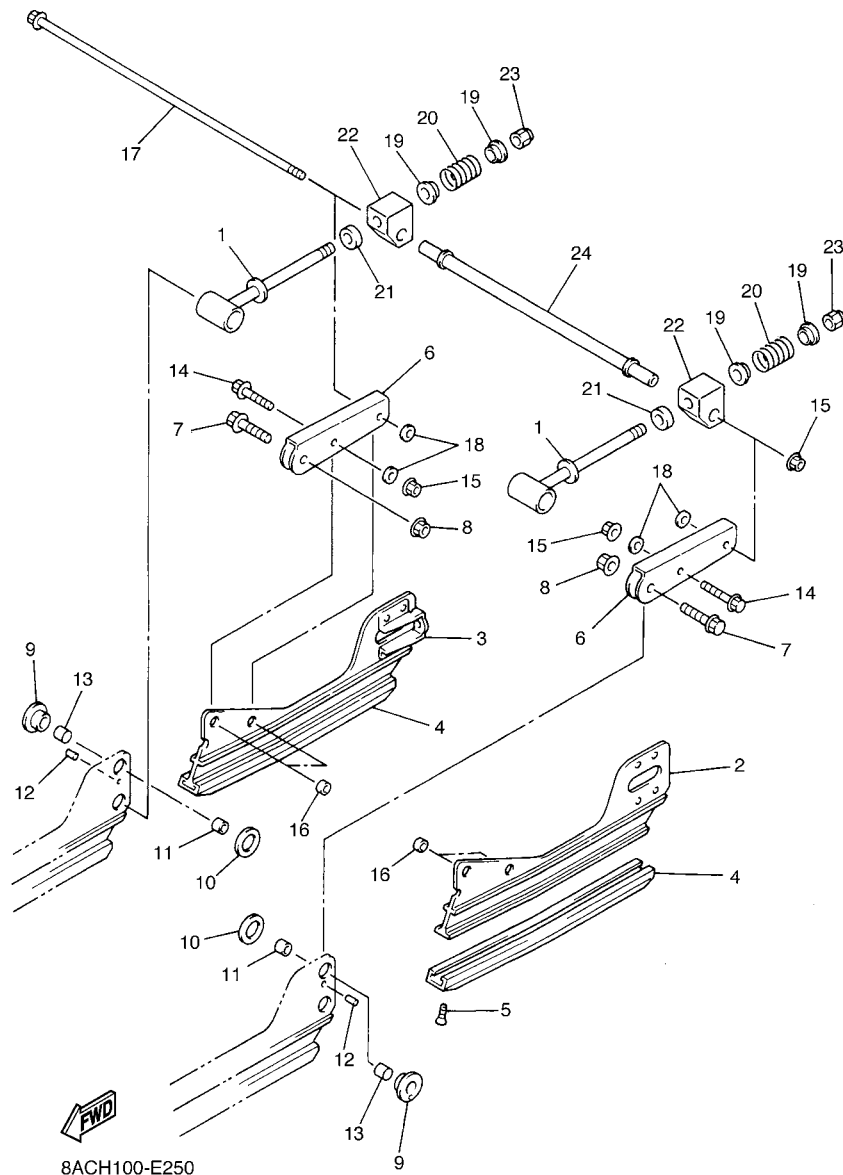
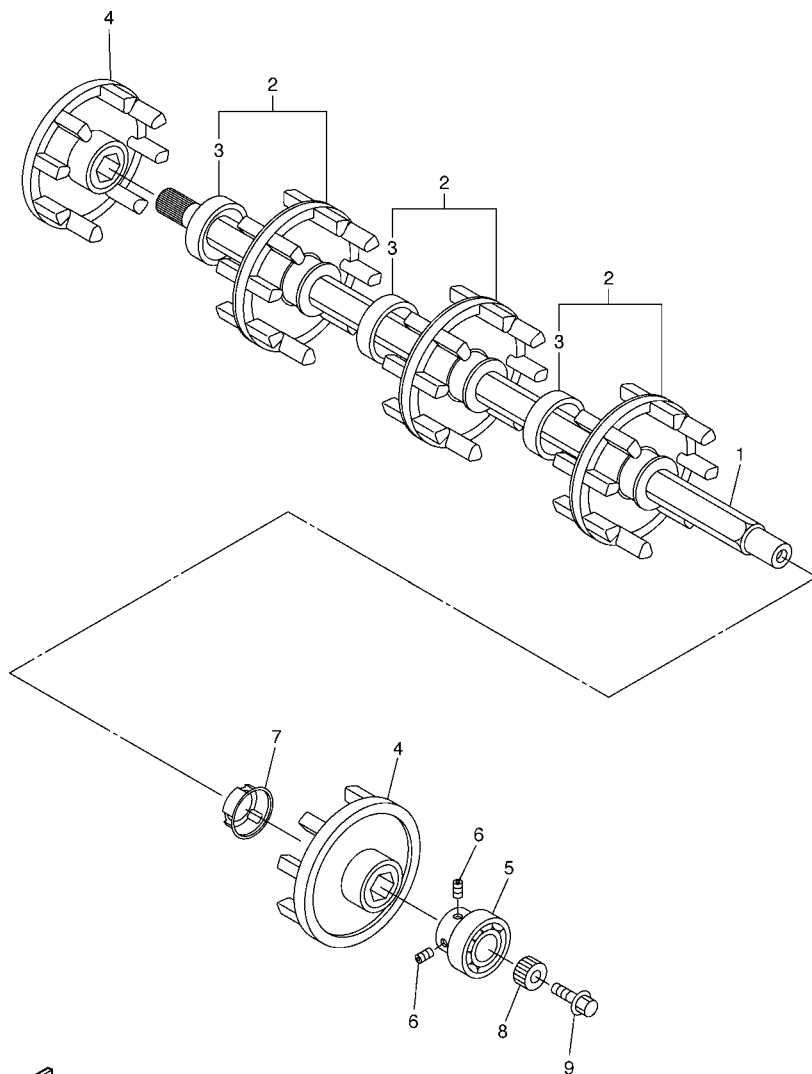


FIG. 29 TRACK SUSPENSION 3

REF. NO.	PART NO.	DESCRIPTION	8CS5	8CS6	REMARKS
1	83R-47337-00	SHAFT, PIVOT	2	2	
2	8FM-W4741-10	FRAME, SLIDING	1	1	
3	8FM-W4741-10	FRAME, SLIDING	1	1	
4	8AC-47424-00	RUNNER, SLIDING 4	2	2	
5	90151-06010	SCREW, COUNTERSUNK	2	2	
6	8FM-47333-00	ARM, PIVOT 3	2	2	
7	95817-10030	BOLT, FLANGE	2	2	
8	90185-10115	NUT, SELF-LOCKING	2	2	
9	90387-1815A	COLLAR	2	2	
10	90202-22238	WASHER, PLATE	2	2	
11	90387-1014Y	COLLAR	2	2	
12	91609-30008	PIN, SPRING	2	2	
13	90380-16109	BUSH, SOLID	2	2	
14	95817-08035	BOLT, FLANGE	2	2	
15	95607-08200	NUT, SELF-LOCKING	3	3	
16	90387-082J1	COLLAR	4	4	
17	90105-08483	BOLT, FLANGE	1	1	
18	90201-08649	WASHER, PLATE	4	4	
19	83R-23768-00	SEAT, SPRING 1	4	4	
20	90501-407E4	SPRING, COMPRESSION	2	2	
21	83R-47335-00	SPRING	2	2	
22	83R-47446-00	HOOK 1	2	2	
23	95707-12300	NUT, FLANGE	2	2	
24	8AC-47478-00	COLLAR 2	1	1	



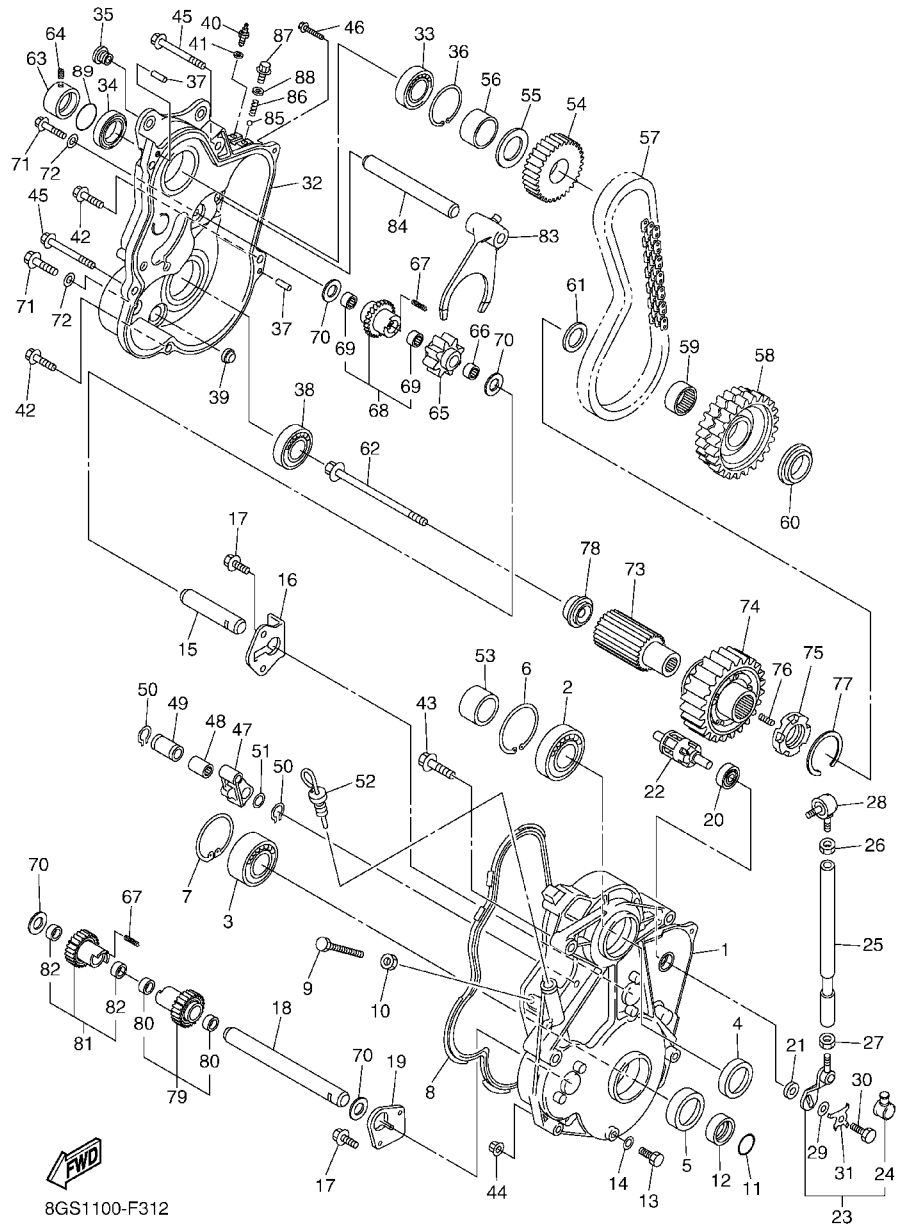
  
8FN1100-E300

FIG. 30 TRACK DRIVE 1

REF. NO.	PART NO.	DESCRIPTION	8GS5	8GS6		REMARKS
1	8GS-47511-00	AXLE, FRONT	1	1		
2	8FN-W4753-00	WHEEL, SPROCKET 1	3	3		
3	90387-514Y2	.COLLAR	1	1		
4	8FN-47532-00	WHEEL, SPROCKET 2	2	2		
5	93306-20589	BEARING	1	1		
6	90113-06064	BOLT, SET	2	2		
7	8FN-47377-00	CAP	1	1		
8	8EK-47715-00	JOINT	1	1		
9	95827-10025	BOLT, FLANGE	1	1		

FIG. 31 TRACK DRIVE 2

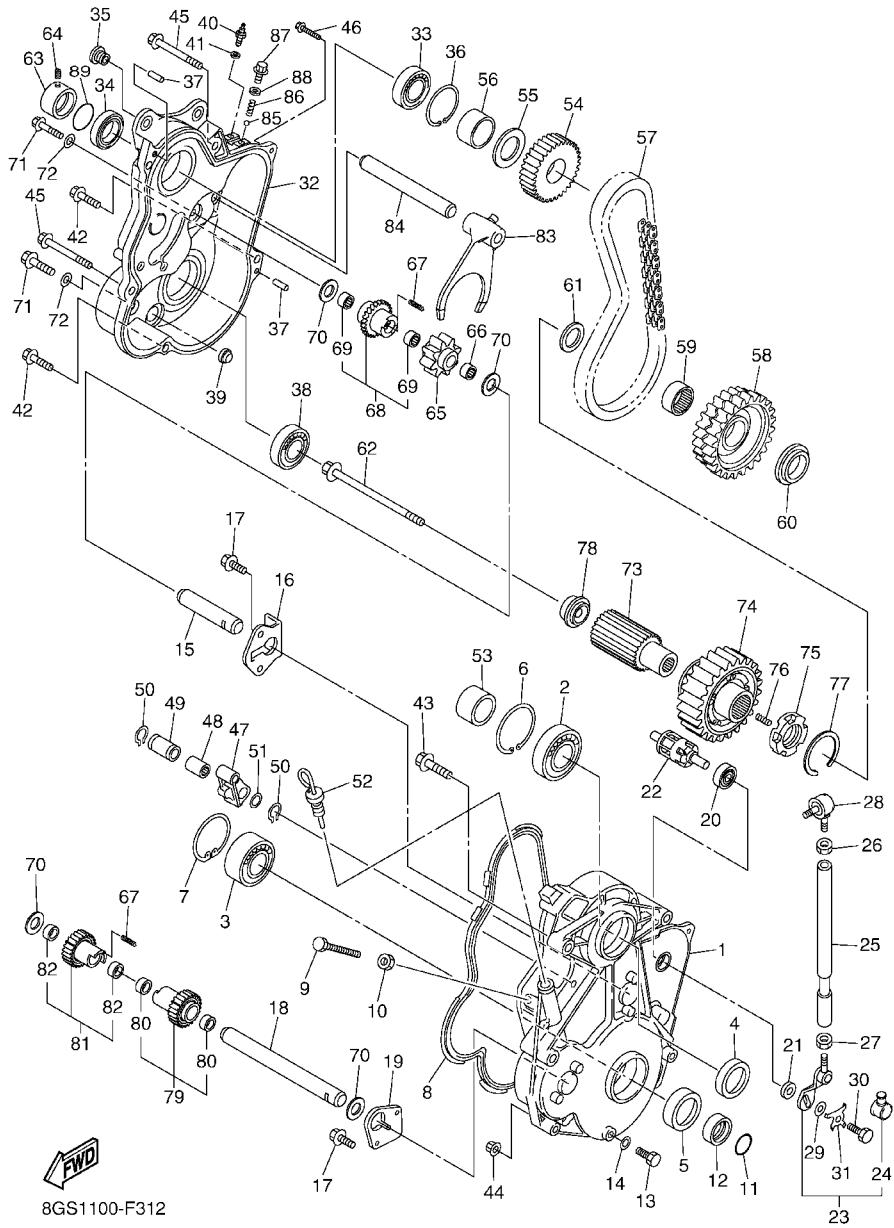
REF. NO.	PART NO.	DESCRIPTION	8GS5	8GS6	REMARKS
1	8GS-47541-00	HOUSING, CHAIN	1	1	
2	93306-20601	BEARING	1	1	
3	93304-20511	BEARING	1	1	
4	93102-30012	OIL SEAL	1	1	
5	93102-35010	OIL SEAL	1	1	
6	99009-62500	CIRCLIP	1	1	
7	99009-52500	CIRCLIP	1	1	
8	8GS-47558-00	RING, HOUSING	1	1	
9	90101-10357	BOLT	1	1	
10	95307-10600	NUT	1	1	
11	93210-25071	O-RING	1	1	
12	90387-2508C	COLLAR	1	1	
13	97007-08014	BOLT	1	1	
14	90210-08017	WASHER, SEAL	1	1	
15	8GS-1761A-00	SHAFT, 1	1	1	
16	8CW-47591-00	PLATE	1	1	
17	90105-060A6	BOLT, FLANGE	4	4	
18	8GS-1761E-00	SHAFT 2	1	1	
19	8GS-47591-00	PLATE	1	1	
20	93306-00208	BEARING	1	1	
21	93102-15212	OIL SEAL	1	1	
22	8GS-18541-01	CAM, SHIFT	1	1	
23	8GS-18191-00	LEVER	1	1	
24	2H9-18154-00	.COVER, DUST	1	1	
25	8GS-18115-00	ROD, SHIFT	1	1	
26	90170-08358	NUT	1	1	
27	95307-08700	NUT	1	1	



8GS1100-F312

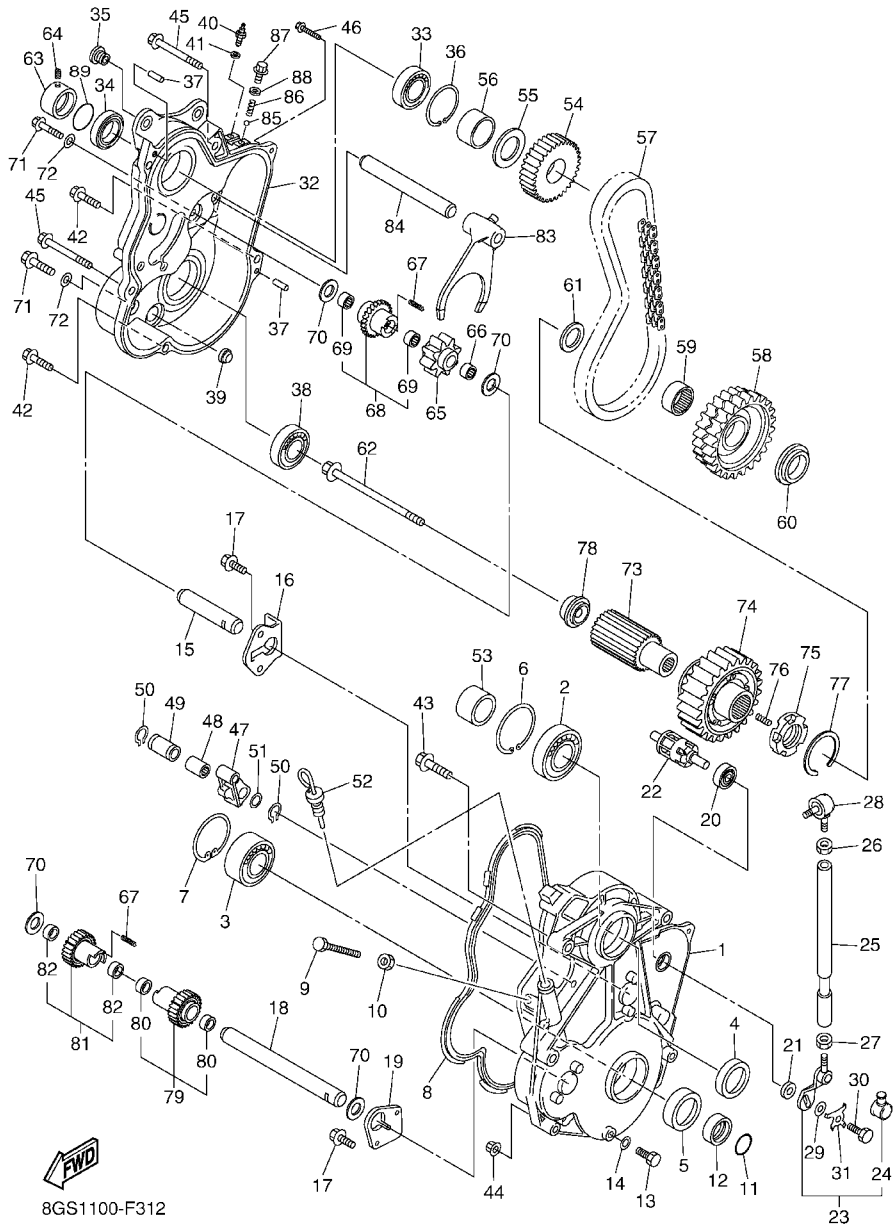
FIG. 31 TRACK DRIVE 2

REF. NO.	PART NO.	DESCRIPTION	8GS5	8GS6	REMARKS
28	3X3-18157-10	JOINT 2	1	1	
29	90201-06099	WASHER, PLATE	1	1	
30	90101-06047	BOLT	1	1	
31	8GS-47554-01	WASHER, LOCK	1	1	
32	8GS-47543-00	CAP, HOUSING	1	1	
33	93306-20511	BEARING	1	1	
34	93102-35010	OIL SEAL	1	1	
35	90179-10679	NUT	2	2	
36	99009-52500	CIRCLIP	1	1	
37	93606-20044	PIN, DOWEL	2	2	
38	93306-00711	BEARING	1	1	
39	3Y1-15361-00	GAUGE, LEVEL	1	1	
40	5LP-82540-01	NEUTRAL SWITCH ASSY	1	1	
41	90430-10148	GASKET	1	1	
42	95827-08030	BOLT, FLANGE	3	3	
43	95827-10045	BOLT, FLANGE	2	2	
44	95607-10200	NUT, U FLANGE	1	1	
45	95827-10090	BOLT, FLANGE	2	2	
46	95827-06025	BOLT, FLANGE	1	1	
47	8ES-47613-00	HOLDER	1	1	
48	93311-32685	BEARING	1	1	
49	90387-22005	COLLAR	1	1	
50	99009-26400	CIRCLIP	2	2	
51	90201-266P2	WASHER, PLATE	1	1	
52	8GS-47546-00	LEVEL, OIL	1	1	
53	90387-30005	COLLAR	1	1	
54	8FA-17682-00	SPROCKET, CHAIN DRIVE (20T)	1	1	



8GS1100-F312

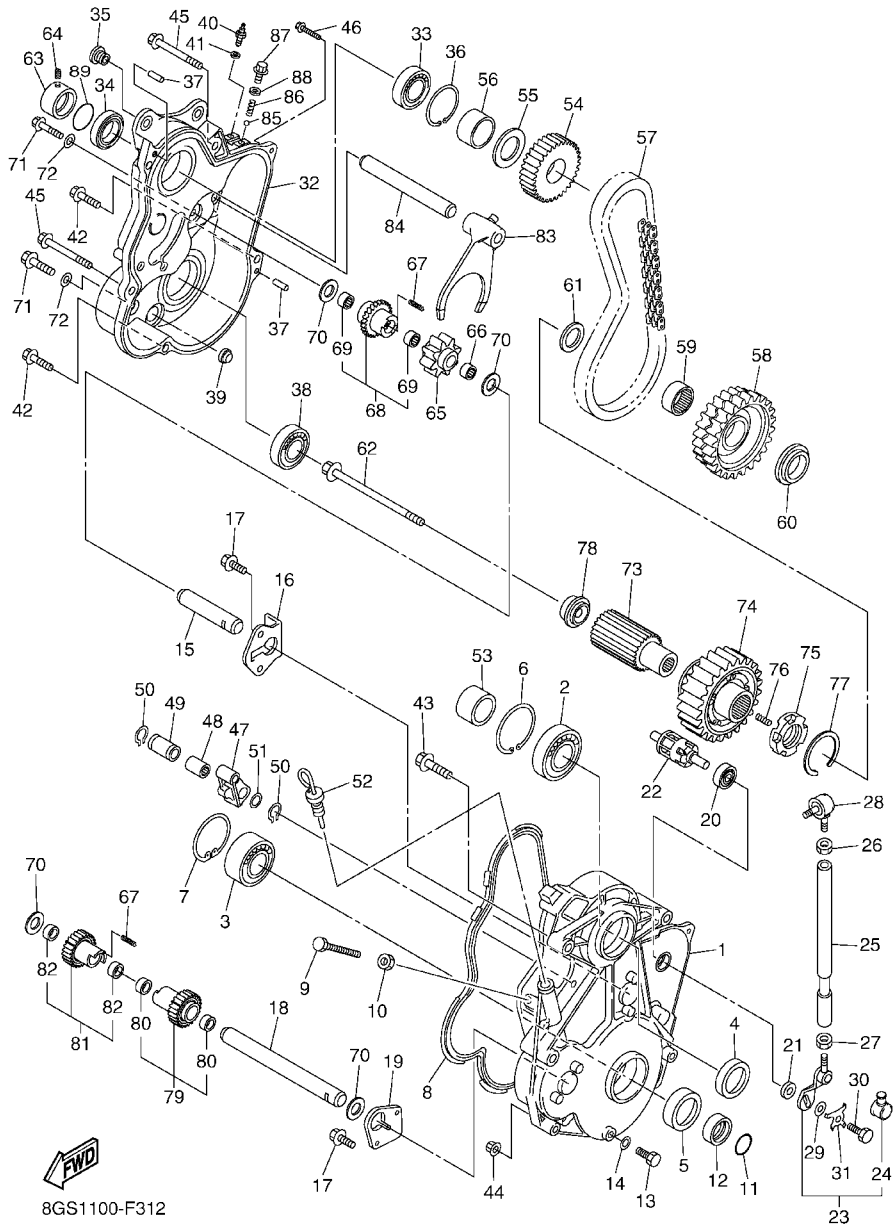
FIG. 31 TRACK DRIVE 2

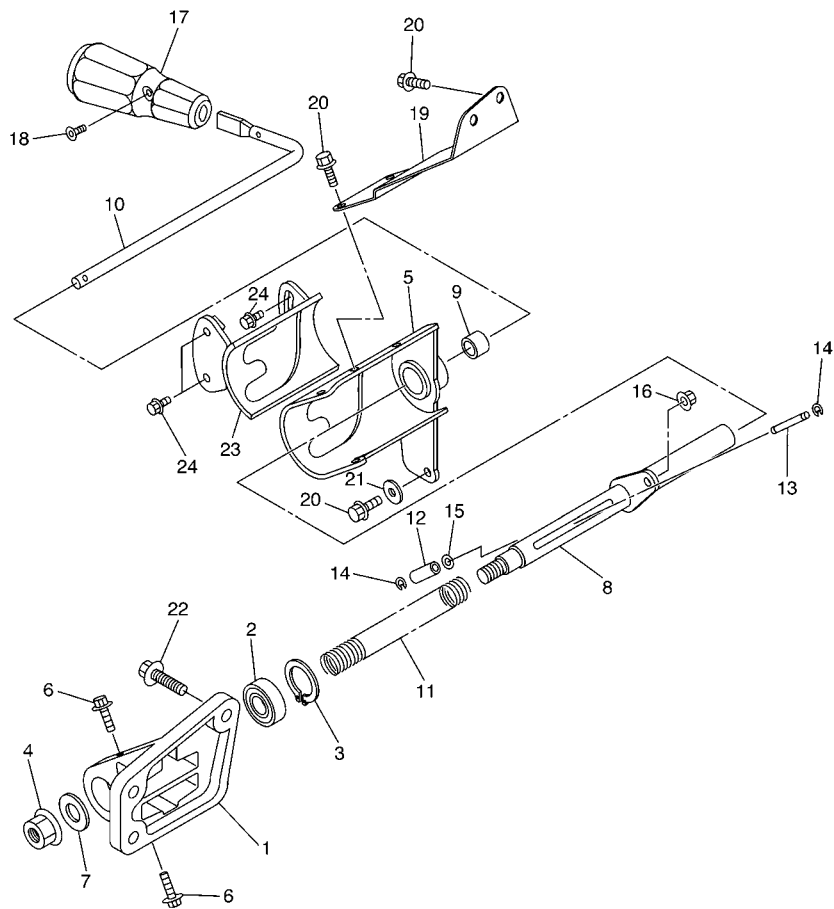


REF. NO.	PART NO.	DESCRIPTION	8GS5	8GS6	REMARKS
55	90208-26002	WASHER, CONICAL SPRING	1	1	
56	90387-26007	COLLAR	1	1	
57	94890-09068	CHAIN (68L)	1	1	
58	8GS-47587-99	SPROCKET, CHAIN DRIVEN	1	1	
59	93317-33179	BEARING	1	1	
60	90387-2008G	COLLAR	1	1	
61	90201-320S3	WASHER, PLATE	1	1	
62	90105-10223	BOLT, FLANGE	1	1	
63	90387-25018	COLLAR	1	1	
64	90113-06064	BOLT, SET	1	1	
65	8FB-17692-00	SPROCKET, DRIVE (18T)	1	1	
66	93317-21578	BEARING	1	1	
67	90501-060A1	SPRING, COMPRESSION	2	2	
68	8GS-1714A-01	REVERSE PINION ASSY.	1	1	
69	93317-21578	BEARING	2	2	
70	90201-16245	WASHER, PLATE	4	4	
71	90105-060A6	BOLT, FLANGE	2	2	
72	90210-06006	WASHER, SEAL	2	2	
73	8GS-47571-00	JOURNAL 1	1	1	
74	8GS-17243-01	GEAR, REVERSE WHEEL 1	1	1	
75	8CW-17492-00	DOG, TRANSMISSION SHIFT	1	1	
76	90501-066J5	SPRING, COMPRESSION	5	5	
77	93440-39175	CIRCLIP	1	1	
78	8GS-47564-00	COLLAR	1	1	
79	8GS-17210-00	1ST WHEEL GEAR ASSY	1	1	

FIG. 31 TRACK DRIVE 2

REF. NO.	PART NO.	DESCRIPTION	8GS5	8GS6	REMARKS
80	93317-21578	.BEARING	2	2	
81	8GS-17110-01	1ST PINION GEAR ASSY	1	1	
82	93317-21578	.BEARING	2	2	
83	8GS-18511-00	FORK, SHIFT 1	1	1	
84	8GS-18531-00	BAR, SHIFT FORK GUIDE 1	1	1	
85	93503-08007	BALL	1	1	
86	90501-10353	SPRING, COMPRESSION	1	1	
87	90105-14003	BOLT, FLANGE	1	1	
88	90430-14043	GASKET	1	1	
89	93210-25642	O-RING	1	1	

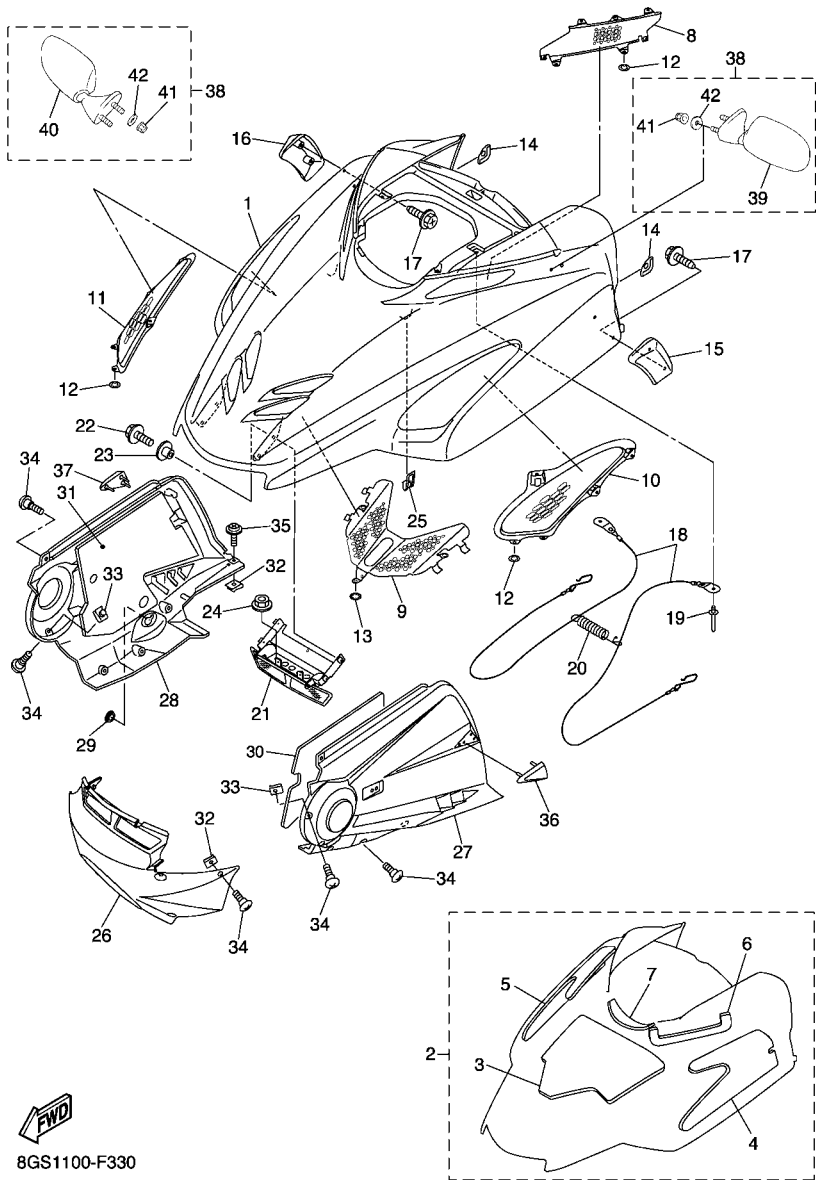




8GS3100-G320

FIG. 32 TRACK DRIVE 3

REF. NO.	PART NO.	DESCRIPTION	8GS5	8GS6	REMARKS
1	8GS-18164-00	KNOB, SHIFTER	1	1	
2	93306-20212	BEARING	1	1	
3	99009-35500	CIRCLIP	1	1	
4	95607-12200	NUT, SELF-LOCKING	1	1	
5	8GS-18161-01	GUIDE, PLATE STOPPER	1	1	
6	95827-08016	BOLT, FLANGE	2	2	
7	90201-12317	WASHER, PLATE	1	1	
8	8GS-18104-01	SHIFT GUIDE COMP.	1	1	
9	90384-19001	BUSH, BIMETAL FORMED	1	1	
10	8GS-18152-01	LEVER, SHIFT 4	1	1	
11	90501-130A0	SPRING, COMPRESSION	1	1	
12	90387-06059	COLLAR	1	1	
13	90249-06002	PIN	1	1	
14	93410-06053	CIRCLIP	2	2	
15	90201-06042	WASHER, PLATE	1	1	
16	95607-06200	NUT, SELF U-FLANGE	1	1	
17	8GS-18174-00	KNOB, SHIFT LEVER	1	1	
18	90151-05048	SCREW, COUNTERSUNK	1	1	
19	8GS-18128-01	BRACKET	1	1	
20	95827-08014	BOLT, FLANGE	5	5	
21	90201-08060	WASHER, PLATE	1	1	
22	95827-08020	BOLT, FLANGE	3	3	
23	8GS-18179-01	GUIDE	1	1	
24	95812-06012	BOLT, FLANGE	3	3	



**FWD**  
8GS1100-F330

**FIG. 33 SHROUD**

REF. NO.	PART NO.	DESCRIPTION	8GS5	8GS6	REMARKS
1	8FN-77111-00-P2	SHROUD	1	1	UR DRMK
	8FN-77111-00-P3	SHROUD	1		UR DBNM8
	8FN-77111-00-P3	SHROUD		1	UR DBNM8(EUR,RUS)
2	8FN-W7726-00	LINING SET	1	1	
3	8FN-77271-00	.DAMPER, NOISE 11	1	1	
4	8FN-77272-00	.DAMPER, NOISE 12	1	1	
5	8FN-77273-00	.DAMPER, NOISE 13	1	1	
6	8FN-77264-00	.LINING, SHROUD 4	1	1	
7	8DS-84366-00	.DAMPER, HEADLIGHT 1	1	1	
8	8FN-77130-00	LOUVER COMP.	1	1	
9	8FN-77134-00	LOUVER 4	1	1	
10	8FN-77109-00	LOUVER 5	1	1	
11	8FN-77108-00	LOUVER 6	1	1	
12	90183-05068	NUT, SPRING	14	14	
13	90183-08065	NUT, SPRING	3	3	
14	8FA-77167-10	TRIM 3	2	2	
15	8FN-77161-00	STRIP, WEATHER 1	1	1	
16	8FN-77162-00	STRIP, WEATHER 2	1	1	
17	97702-50016	SCREW, TAPPING	4	4	
18	8FN-77118-00	STOPPER, SHROUD	2	2	
19	90267-48018	RIVET, BLIND (4.8X18.6 BLACK)	2	2	
20	89A-77159-00	CLAMP, ROD	2	2	
21	8FN-77140-00	HINGE ASSY	1	1	
22	95802-06016	BOLT, FLANGE	4	4	
23	90387-06681	COLLAR	4	4	
24	95602-06200	NUT, SELF-LOCKING	2	2	
25	8FA-77135-00	CLAMP 1	1	1	



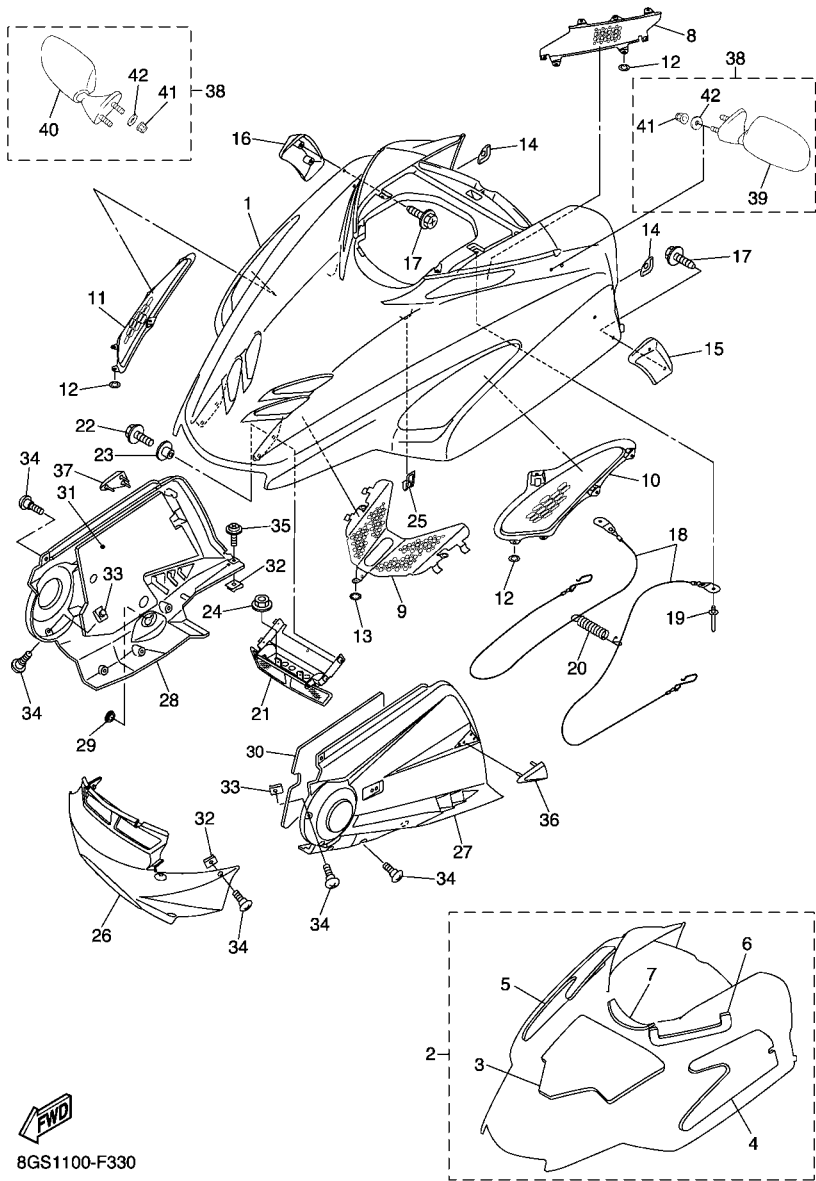
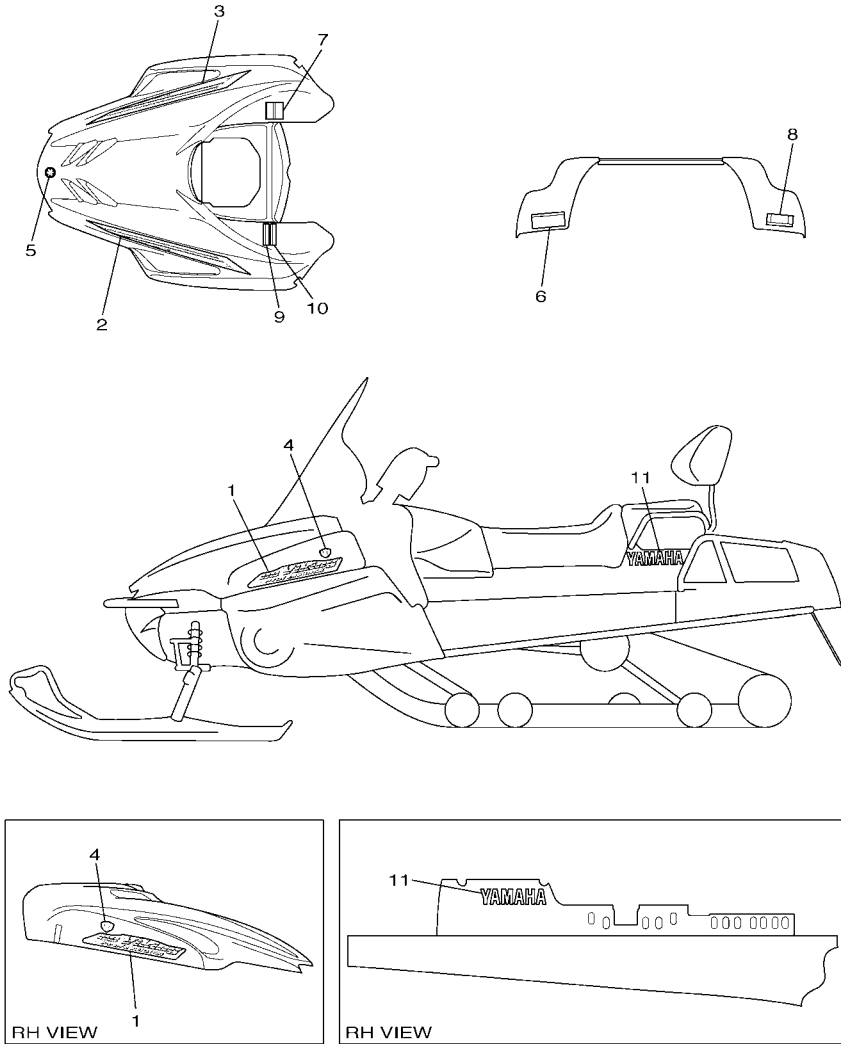


FIG. 33 SHROUD

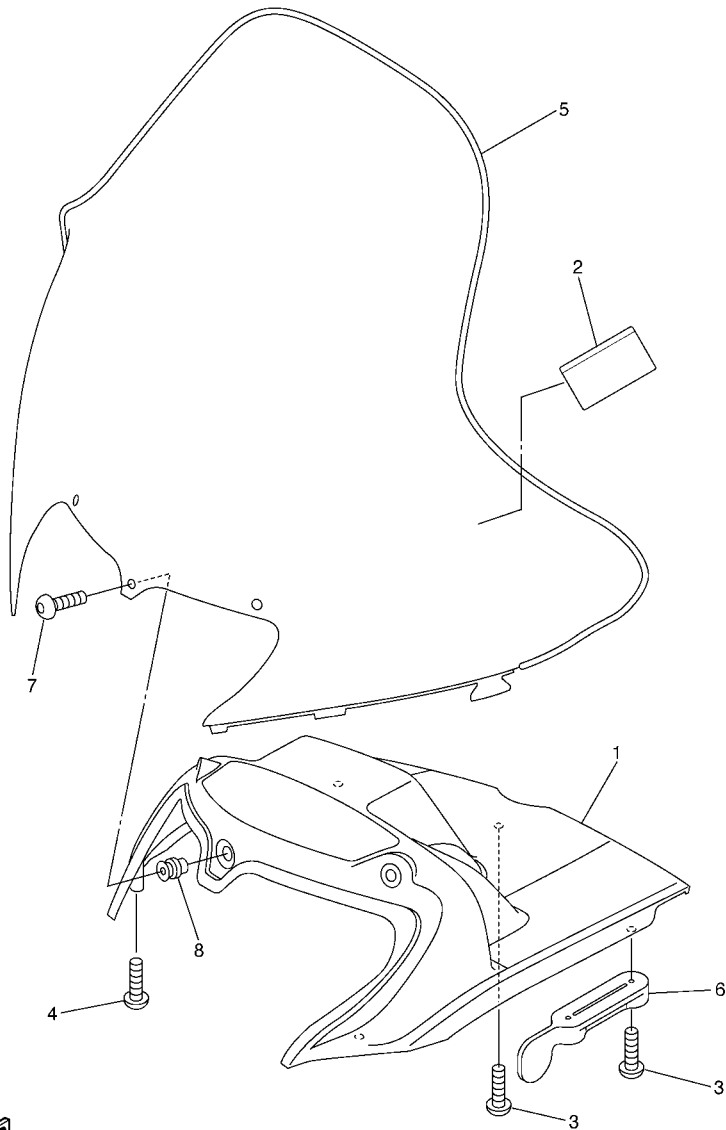
REF. NO.	PART NO.	DESCRIPTION	8GS5	8GS6	REMARKS
26	8FN-21912-00	PANEL, SUB FRAME 1	1	1	
27	8ES-2197H-01	HOOD 3	1	1	
28	8GS-2198H-00	HOOD 4	1	1	
29	90338-30256	PLUG	1	1	
30	8ES-77276-00	DAMPER, NOISE 16	1	1	
31	8GS-77277-00	DAMPER, NOISE 17	1	1	
32	90183-06053	NUT, SPRING	8	8	
33	90183-06100	NUT, SPRING	6	6	
34	90154-06009	SCREW, BINDING	18	18	
35	90159-06011	SCREW, WITH WASHER	2	2	
36	8FA-77561-00	PROTECTOR, SIDE 1	1	1	
37	8FA-77562-00	PROTECTOR, SIDE 2	1	1	
38	8CR-W2628-10	REAR VIEW MIRROR SET	1	1	
39	4SV-26280-00	.REAR VIEW MIRROR ASSY (LEFT)	1	1	
40	4SV-26290-00	.REAR VIEW MIRROR ASSY (RIGHT)	1	1	
41	95602-06200	.NUT, SELF-LOCKING	4	4	
42	90201-06072	.WASHER, PLATE	4	4	



8GS5100-H340

FIG. 34 EMBLEM

REF. NO.	PART NO.	DESCRIPTION	8GS5	8GS6		REMARKS
1	8GS-77141-10	EMBLEM 1	2	2		UR DRMK
	8GS-77141-20	EMBLEM 1	2			UR DBNM8
	8GS-77141-20	EMBLEM 1		2		UR DBNM8(EUR,RUS)
2	8FN-7711L-30	GRAPHIC, SHROUD	1	1		UR DRMK
	8FN-7711L-40	GRAPHIC, SHROUD	1			UR DBNM8
	8FN-7711L-40	GRAPHIC, SHROUD		1		UR DBNM8(EUR,RUS)
3	8FN-7711M-30	GRAPHIC, SHROUD	1	1		UR DRMK
	8FN-7711M-40	GRAPHIC, SHROUD	1			UR DBNM8
	8FN-7711M-40	GRAPHIC, SHROUD		1		UR DBNM8(EUR,RUS)
4	8FN-7715A-00	EMBLEM 3D	2	2		
5	8AC-2414B-01	EMBLEM	1	1		
6	8DM-77761-E0	LABEL, WARNING 1	1			
	8DM-77761-S0	LABEL, WARNING 1		1		UR FOR EUR
	8GS-77761-R1	LABEL, WARNING 1		1		UR FOR RUS
	8BY-77761-J0	LABEL, WARNING 1		1		UR FOR JPN
7	8FN-77761-E0	LABEL, WARNING 1	1			
	8FN-77761-S0	LABEL, WARNING 1		1		UR FOR EUR
	8FN-77761-R1	LABEL, WARNING 1		1		UR FOR RUS
	8FN-77761-J0	LABEL, WARNING 1		1		UR FOR JPN
8	8GS-77763-E0	LABEL, WARNING 3	1			
	8GS-77763-S0	LABEL, WARNING 3		1		UR FOR EUR,RUS
	8GS-77763-J0	LABEL, WARNING 3		1		UR FOR JPN
9	8ET-2815K-00	LABEL, NOTICE WINDSHIELD 1	1			
10	8ET-2815K-10	LABEL, NOTICE WINDSHIELD 1	1			
11	99246-00200	EMBLEM, YAMAHA	2	2		



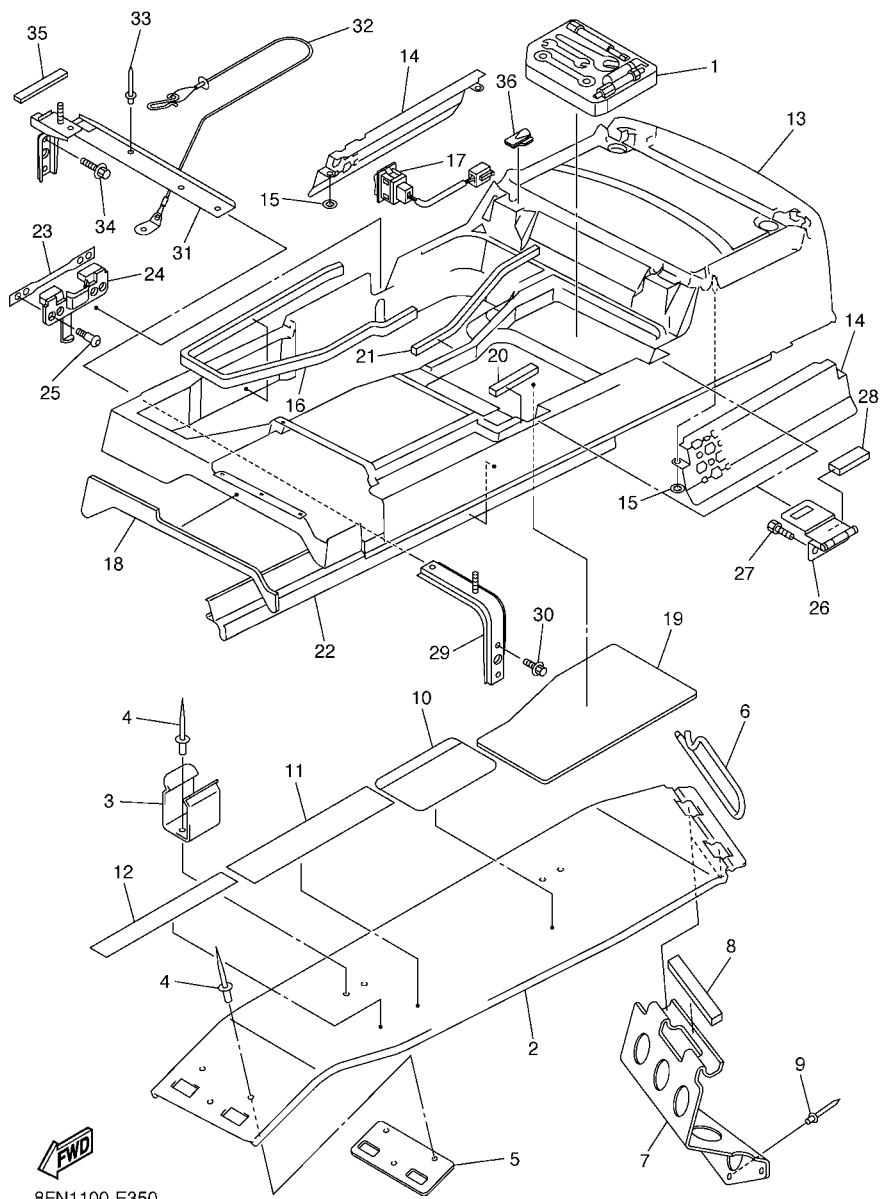
**FWD**  
8FN1100-E340

**FIG. 35 WINDSHIELD**

REF. NO.	PART NO.	DESCRIPTION	8GS5	8GS6		REMARKS
1	8FN-77251-00	COVER, HEADLIGHT	1	1		
2	4B5-2815K-20	LABEL, NOTICE WINDSHIELD 1		1		FOR JPN
3	97702-50016	SCREW, TAPPING	3	3		
4	97702-50020	SCREW, TAPPING	2	2		
5	8FN-K7210-00	WINDSHIELD COMP.	1			
	8FN-77210-00	WINDSHIELD COMP.		1		
6	82H-77223-00	FASTNER	2	2		
7	90149-05299	SCREW	3	3		
8	90179-05523	NUT	3	3		
-----						
-----						
-----						
-----						
-----						
-----						
-----						
-----						
-----						
-----						

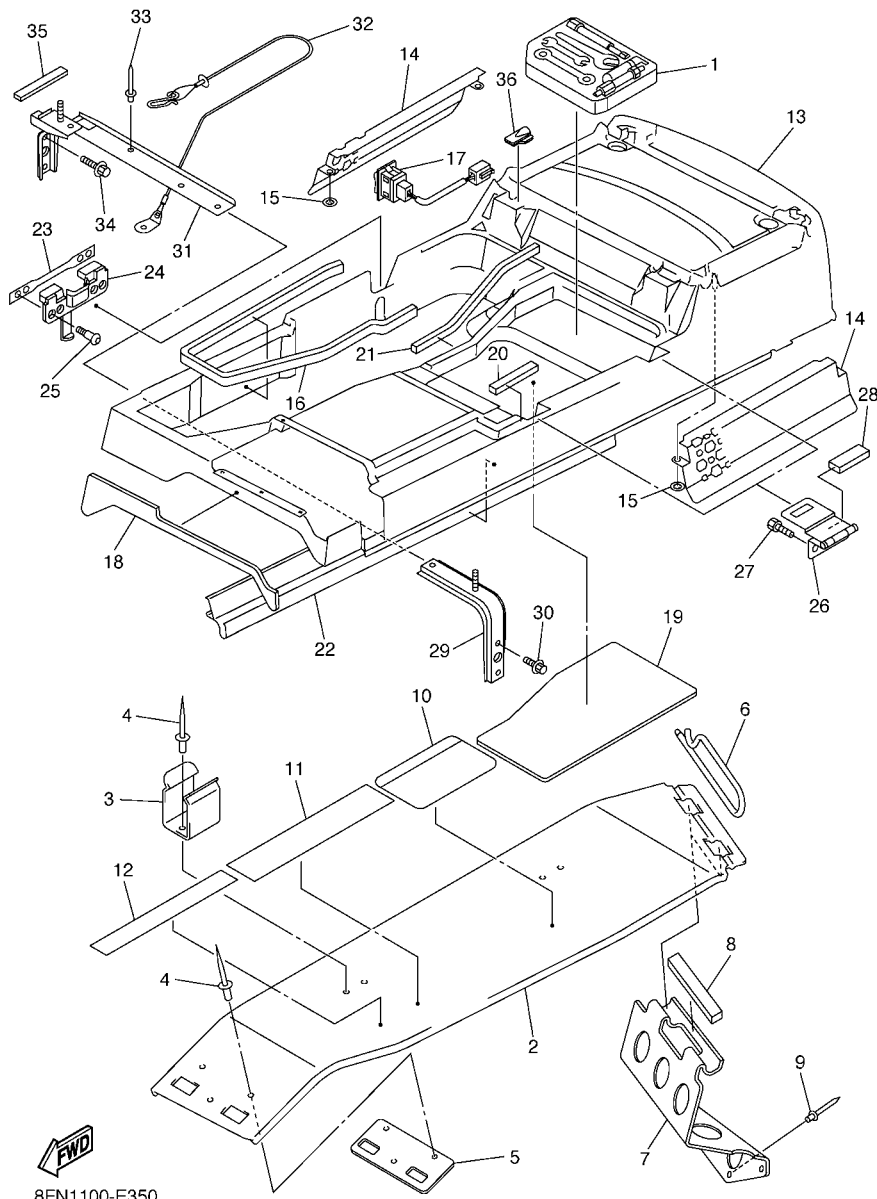
**FIG. 36 GUARD & LUGGAGE BOX**

REF. NO.	PART NO.	DESCRIPTION	8GS5	8GS6	REMARKS
1	8FN-28100-01	TOOL KIT	1	1	
2	8FA-77311-02	GUARD, DRIVE	1	1	
3	8CR-77338-00	STAY, BELT	2	2	
4	90267-48010	RIVET, BLIND (4.8X12 YELLOW)	7	7	
5	8FA-77373-00	PROTECTOR	1	1	
6	8CR-77384-01	PIN	1	1	
7	8FN-21973-00	HOOK	1	1	
8	8CR-77319-00	DAMPER 1	1	1	
9	90267-47195	RIVET, BLIND (4.7X16.4 YELLOW)	3	3	
10	8BD-77762-00	LABEL, WARNING 2	1		
	86D-77762-00	LABEL, WARNING 2	1		UR FOR EUR
	8AC-77762-R1	LABEL, WARNING 2	1		UR FOR RUS
	8BD-77762-21	LABEL, WARNING 2	1		UR FOR JPN
11	8GS-47578-00	LABEL 1	1	1	EXCEPT FOR JPN
12	8ES-1417E-00	LABEL, CAUTION	1	1	
13	8FN-77390-00	LUGGAGE BOX ASSY	1	1	
14	8FN-77133-00	LOUVER 3	2	2	
15	90183-05068	NUT, SPRING	4	4	
16	8FN-2414G-00	SEAL	1	1	
17	8ET-82917-00	SWITCH	1	1	
18	8FN-77262-00	LINING, SHROUD 2	1	1	
19	8FN-77263-00	LINING, SHROUD 3	1	1	
20	8FN-241A3-00	SEAL 3	1	1	
21	8FN-241A4-00	SEAL 4	1	1	
22	8FN-2196T-00	TRIM 1	2	2	
23	8FN-2478C-00	BAR, SEAT LEVER	1	1	
24	8FN-24723-00	DAMPER, SEAT	1	1	



8FN1100-E350

**FIG. 36 GUARD & LUGGAGE BOX**



REF. NO.	PART NO.	DESCRIPTION	QTY		REMARKS
			8CS5	8CS6	
25	90111-05020	BOLT,HEX. SOCKET BUTTON	4	4	
26	8FN-24772-00	HINGE ASSY	2	2	
27	90110-06043	BOLT, HEXAGON SOCKET HEAD	4	4	
28	8FN-2414E-00	SEAL 2	2	2	
29	8FN-2194N-00	BRACKET, FUEL TANK 1	1	1	
30	95812-08014	BOLT, FLANGE	2	2	
31	8FN-2194R-00	BRACKET, FUEL TANK 2	1	1	
32	8FN-2478E-00	CABLE, SEAT LOCK	1	1	
33	90267-47186	RIVET, BLIND (4.7X16.4 BLACK)	1	1	
34	95812-08014	BOLT, FLANGE	3	3	
35	8FN-241A3-00	SEAL 3	1	1	
36	8FN-24742-00	GROMMET	1	1	

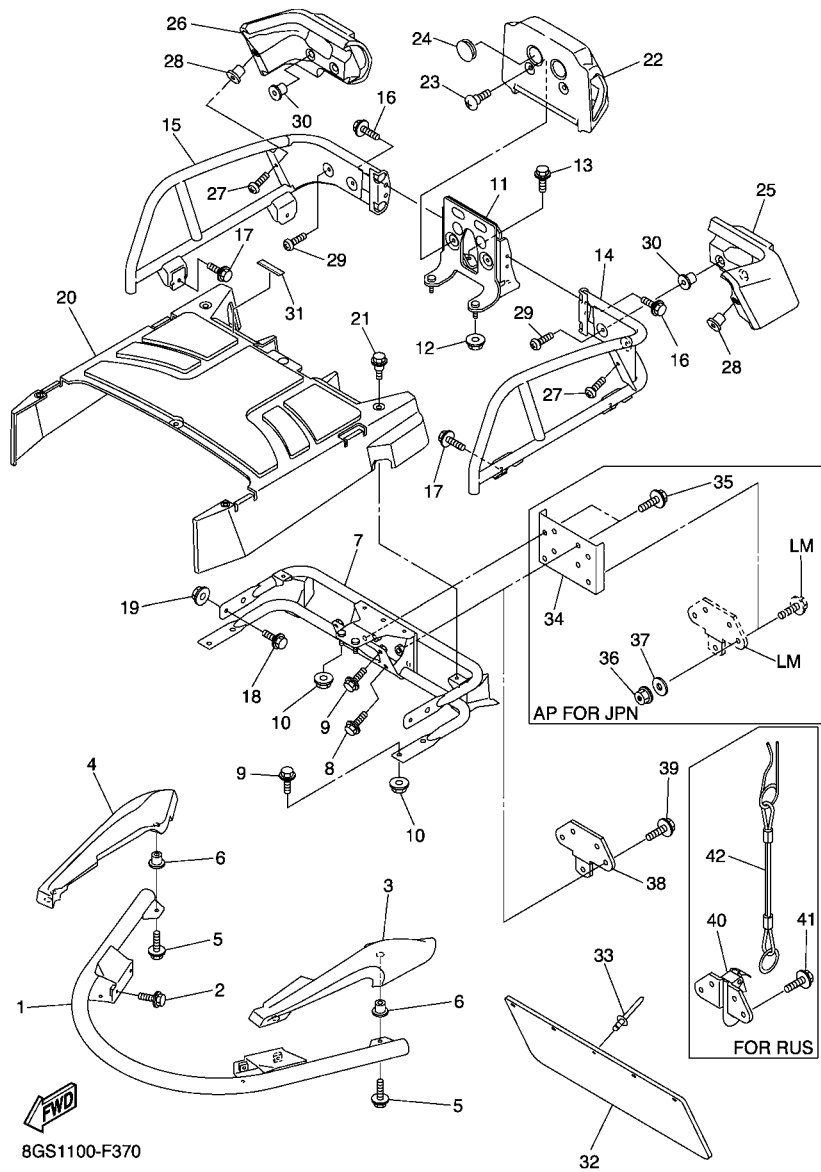


FIG. 37 BUMPER

REF. NO.	PART NO.	DESCRIPTION	8GS5	8GS6	REMARKS
1	8FN-77511-00	BUMPER, FRONT 1	1	1	
2	95822-08020	BOLT, FLANGE	4	4	
3	8FN-77523-00	END, BUMPER	1	1	
4	8FN-77524-00	END, BUMPER	1	1	
5	95822-06020	BOLT, FLANGE	4	4	
6	90179-06520	NUT	4	4	
7	8FN-77541-00	BUMPER, REAR 1	1	1	
8	95822-10020	BOLT, FLANGE	2	2	
9	95822-08016	BOLT, FLANGE	6	6	
10	95702-08500	NUT, WITH WASHER	6	6	
11	8FN-77542-00	BUMPER, REAR 2	1	1	
12	95702-08500	NUT, WITH WASHER	2	2	
13	95812-08016	BOLT, FLANGE	2	2	
14	8FN-77543-00	BUMPER, REAR 3	1	1	
15	8FN-77544-00	BUMPER, REAR 4	1	1	
16	95822-08016	BOLT, FLANGE	4	4	
17	95822-10020	BOLT, FLANGE	4	4	
18	95802-06014	BOLT, FLANGE	2	2	
19	95702-06500	NUT, FLANGE	2	2	
20	8FN-77551-00	PROTECTOR 1	1	1	
21	90109-06174	BOLT	5	5	
22	8FN-77552-00	PROTECTOR 2	1	1	
23	90154-06009	SCREW, BINDING	2	2	
24	90338-28242	PLUG	2	2	
25	8FN-77553-00	PROTECTOR 3	1	1	
26	8FN-77554-00	PROTECTOR 4	1	1	
27	98902-06016	SCREW, BIND	2	2	

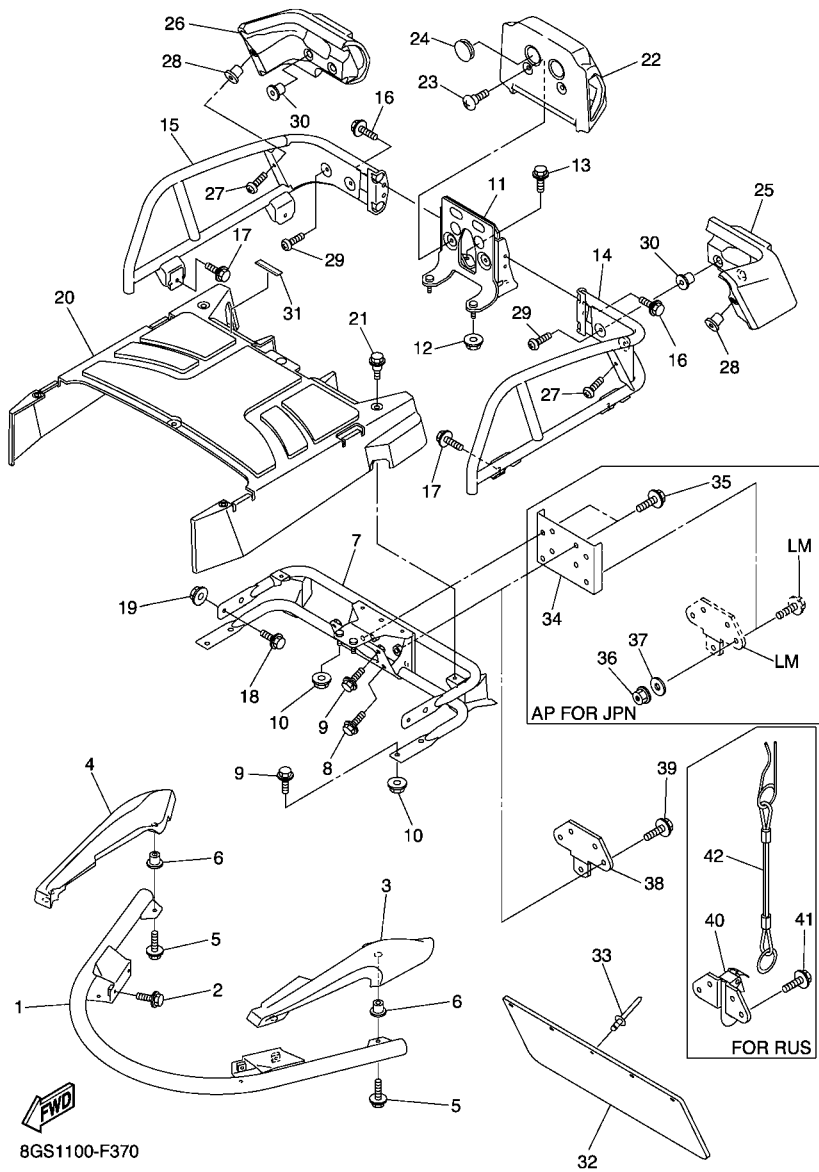
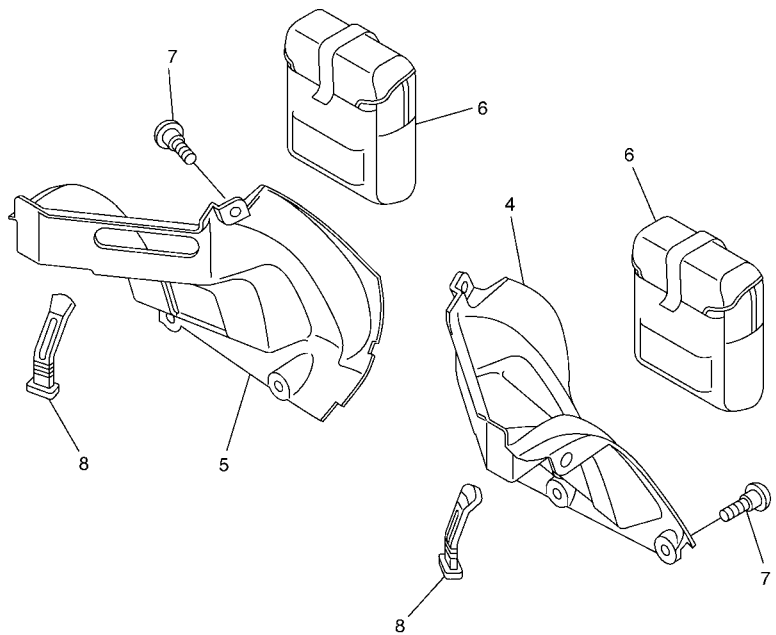
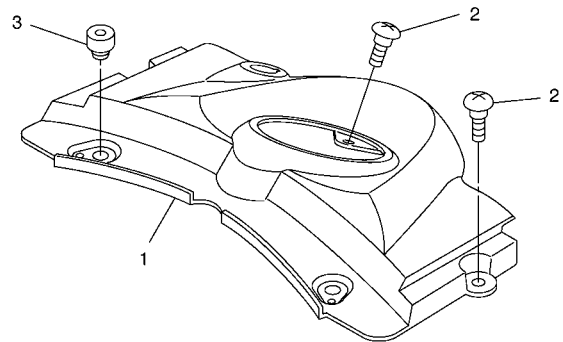


FIG. 37 BUMPER

REF. NO.	PART NO.	DESCRIPTION	8GS5	8GS6	REMARKS
28	90179-06520	NUT	2	2	
29	98902-08020	SCREW, BIND	4	4	
30	90179-08011	NUT	4	4	
31	8FM-24897-01	EMBLEM	1		
	8FM-24897-11	EMBLEM	1		UR FOR EUR,RUS
	4KN-24877-C0	LABEL, CAUTION	1		UR FOR JPN
32	83R-77595-00	FLAP	1	1	
33	90267-48086	RIVET, BLIND (4.8X19 BLACK)	5	5	
34	80M-77591-00	BRACKET, HITCH 1	1		AP FOR JPN
35	95822-08025	BOLT, FLANGE	4		AP FOR JPN
36	95712-08300	NUT, FLANGE	4		AP FOR JPN
37	92902-08600	WASHER, PLATE	4		AP FOR JPN
38	84R-77592-00	BRACKET, HITCH 2	1		
39	95822-08025	BOLT, FLANGE	4		
40	86D-77591-00	BRACKET, HITCH 1	1		FOR RUS
41	95822-08025	BOLT, FLANGE	4		FOR RUS
42	8U1-77157-00	PIN, HINGE	1		FOR RUS



8FN1100-E370

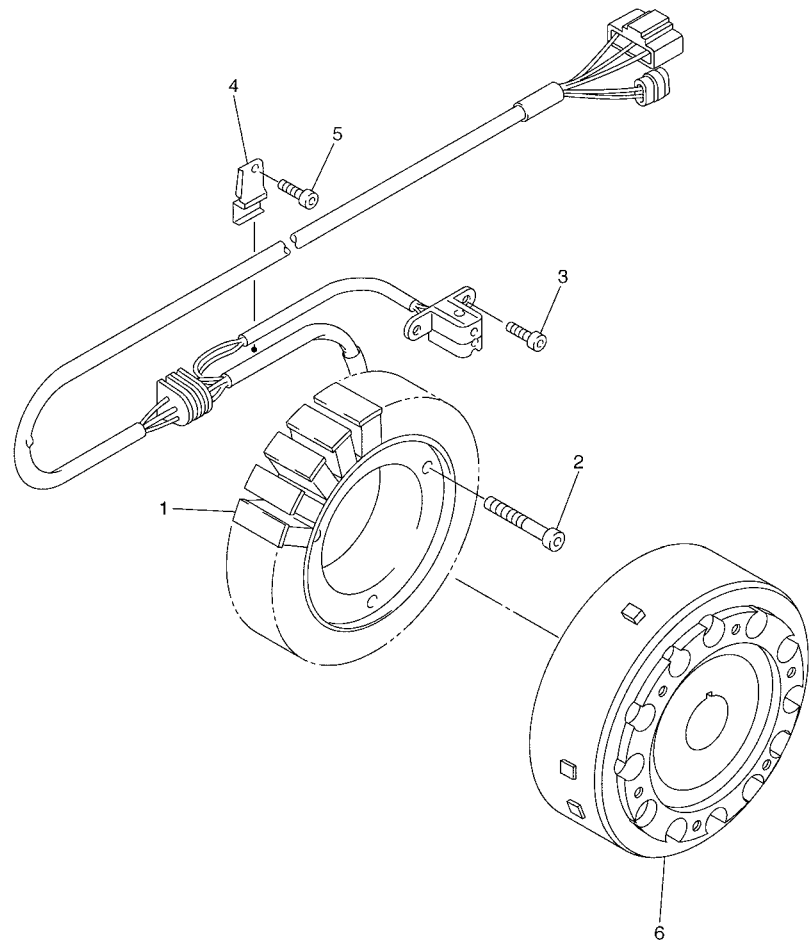
**FIG. 38 INSTRUMENT PANEL**

REF. NO.	PART NO.	DESCRIPTION	8GS5	8GS6	REMARKS
1	8FN-77711-00	PANEL, INSTRUMENT	1	1	
2	90149-06263	SCREW	3	3	
3	4N0-27114-00	STOPPER, MAIN STAND	2	2	
4	8FN-77131-00	LOUVER 1	1	1	
5	8FN-77132-00	LOUVER 2	1	1	
6	8GS-77735-00	BOX, GLOVE	2	2	
7	90154-06009	SCREW, BINDING	6	6	
8	8FA-77171-00	BODY, LATCH 1	2	2	





8ES1100-D370



**FIG. 39 GENERATOR**

REF. NO.	PART NO.	DESCRIPTION	8CS5	8CS6			REMARKS
1	8ES-81410-00	STATOR ASSY	1	1			
2	90110-06223	BOLT, HEXAGON SOCKET HEAD	3	3			
3	90110-05034	BOLT, HEXAGON SOCKET HEAD	2	2			
4	8FA-15113-00	PLATE	1	1			
5	90110-06187	BOLT, HEXAGON SOCKET HEAD	1	1			
6	8ES-81450-01	ROTOR ASSY	1	1			

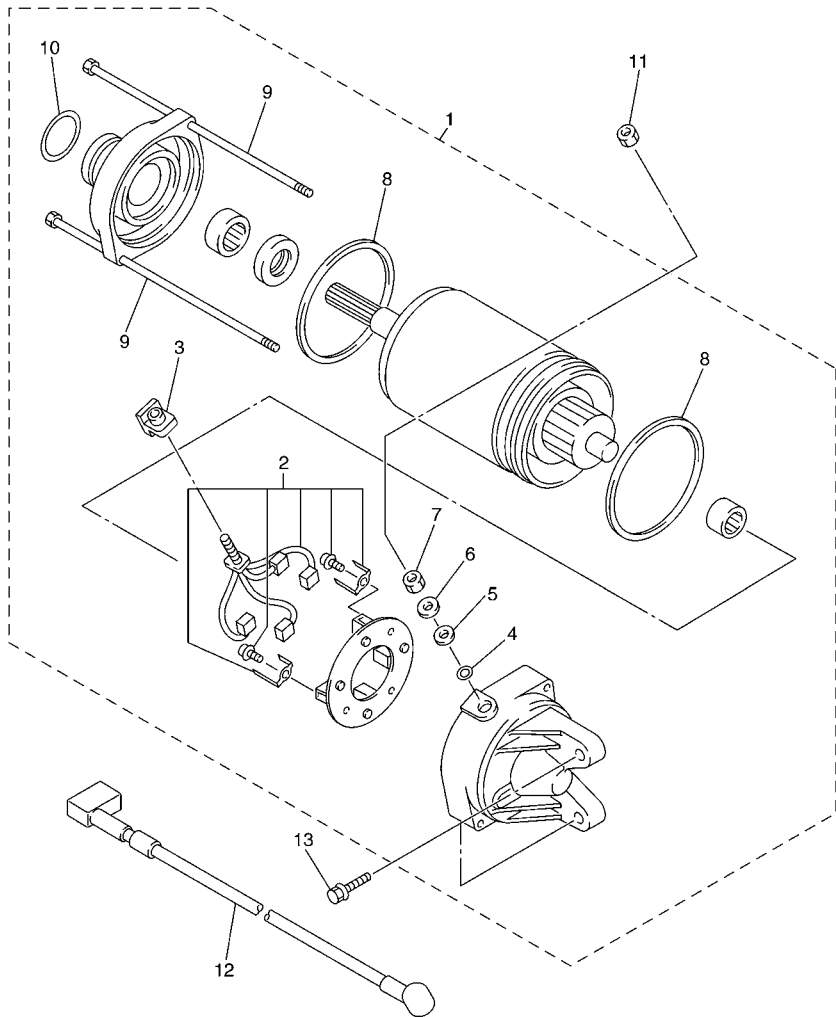
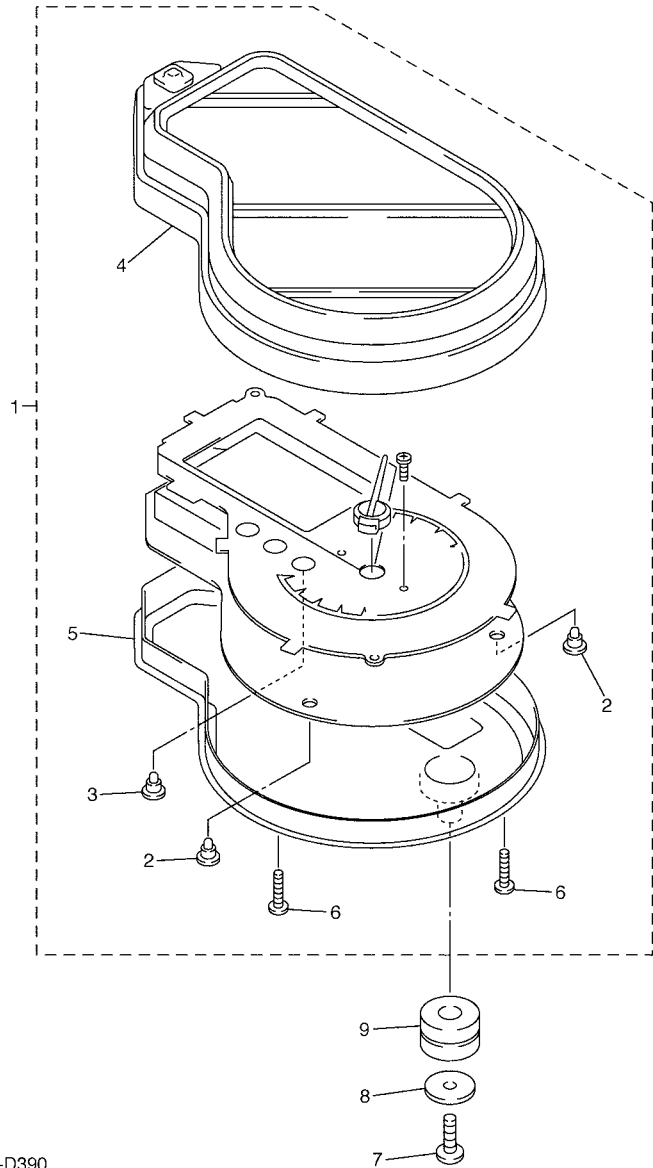


FIG. 40 STARTING MOTOR

REF. NO.	PART NO.	DESCRIPTION	8GS5	8GS6				REMARKS
			1	1				
1	8GL-81890-00	MOTOR ASSY	1	1				
2	2S3-81801-00	.BRUSH SET	1	1				
3	2S3-8182G-00	.BUSH, TERMINAL	1	1				
4	93210-06001	.O-RING	1	1				
5	8FA-8181L-00	.WASHER, PLAIN	1	1				
6	1D7-81835-00	.WASHER	1	1				
7	95302-06700	.NUT	1	1				
8	5PX-81861-00	.GASKET	2	2				
9	8ES-81846-01	.SCREW	2	2				
10	93210-24235	.O-RING	1	1				
11	95302-06700	NUT	1	1				
12	8ES-8183G-00	CORD COMP.	1	1				
13	95812-08030	BOLT, FLANGE	2	2				

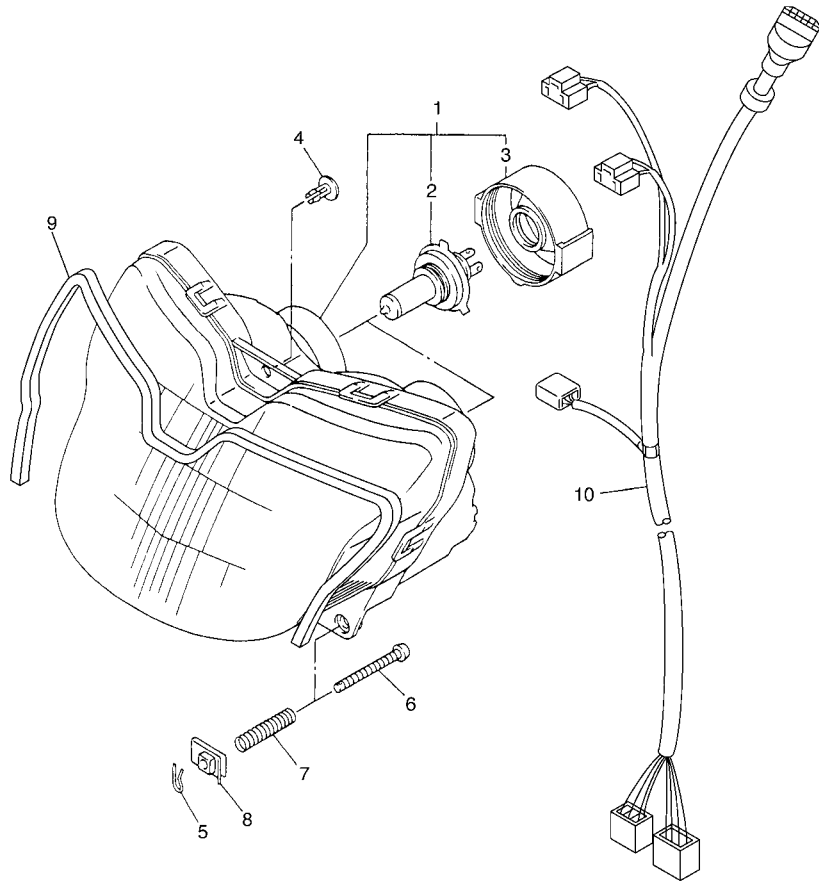
  
8GS3100-G400



  
8ES1100-D390

**FIG. 41 METER**

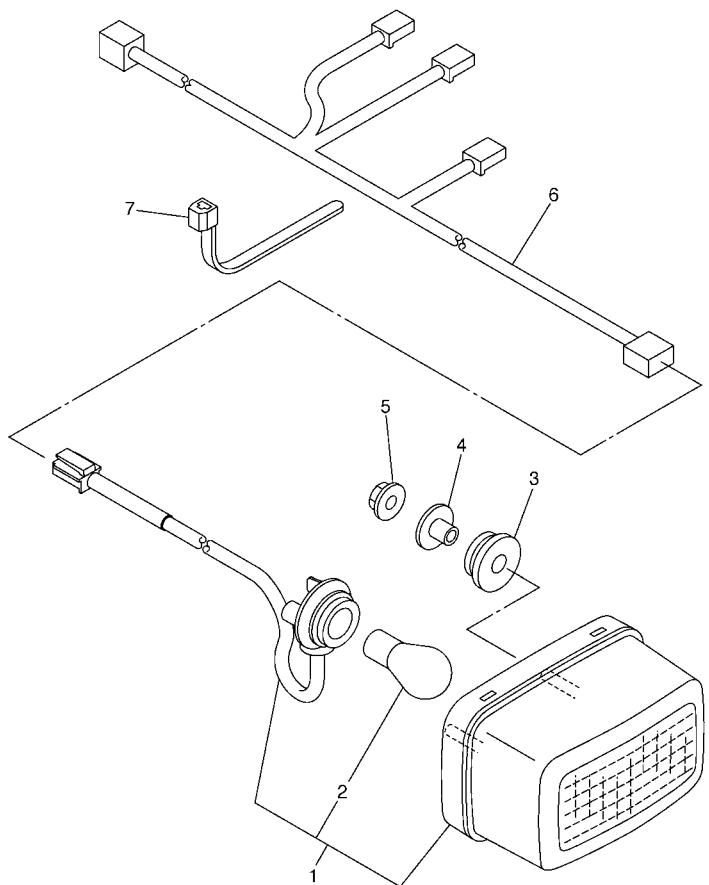
REF. NO.	PART NO.	DESCRIPTION	8GS5	8GS6			REMARKS
1	8FN-83500-01	SPEEDOMETER ASSY (KM/H)	1	1			
2	4WM-83517-00	.BULB (T3 14V-50MA)	6	6			
3	4WM-83517-10	.BULB (T3.4 14V-80MA)	3	3			
4	8EK-8353E-01	.CASE, METER UPPER	1	1			
5	8EK-83572-01	.CASE, SPEEDOMETER LOWER	1	1			
6	5PW-8352S-00	.SCREW, PANEL FITTING	7	7			
7	97702-50016	SCREW, TAPPING	3	3			
8	90201-05725	WASHER, PLATE	3	3			
9	4XV-83513-00	DAMPER	3	3			



8FN1100-E410

**FIG. 42 HEADLIGHT**

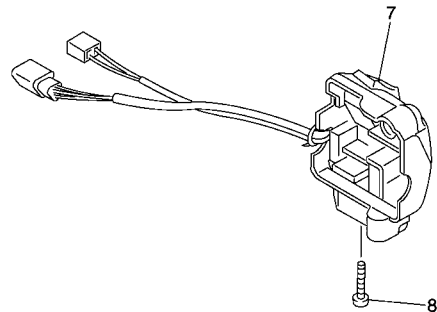
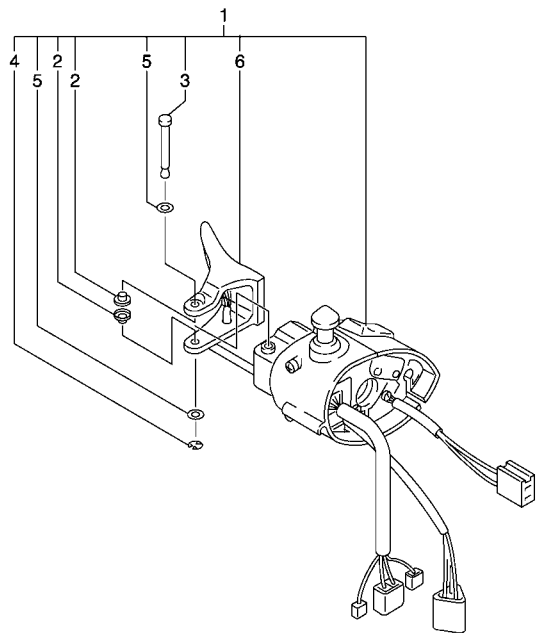
REF. NO.	PART NO.	DESCRIPTION	8GS5	8GS6		REMARKS
1	8DN-84310-01	HEADLIGHT UNIT ASSY	1	1		
2	8G9-84314-00	.BULB (12V-60/55W)	2	2		(H4)HALOGEN
3	8DN-84397-01	.COVER, SOCKET	2	2		
4	90269-06046	RIVET	1	1		
5	8K4-84374-00	CLIP	2	2		
6	8A5-84331-00	SCREW, RIM ADJUSTING	2	2		
7	8A5-84332-00	SPRING, SCREW	2	2		
8	90183-05024	NUT, SPRING	2	2		
9	8FN-8399N-00	INSULATOR 1	1	1		
10	8FN-84359-00	CORD, HEADLIGHT	1	1		



**FIG. 43 TAILLIGHT**

REF. NO.	PART NO.	DESCRIPTION	8CS5	8CS6	REMARKS
1	8FN-84710-00	TAILLIGHT UNIT ASSY	1	1	
2	1A2-84714-41	.BULB (12V-21/5W)	1	1	
3	90480-18007	GROMMET	2	2	
4	90387-06033	COLLAR	2	2	
5	95702-06500	NUT, FLANGE	2	2	
6	8FN-84717-00	CORD, TAILLIGHT	1	1	
7	90464-25004	CLAMP	2	2	

  
 8FN1100-E420



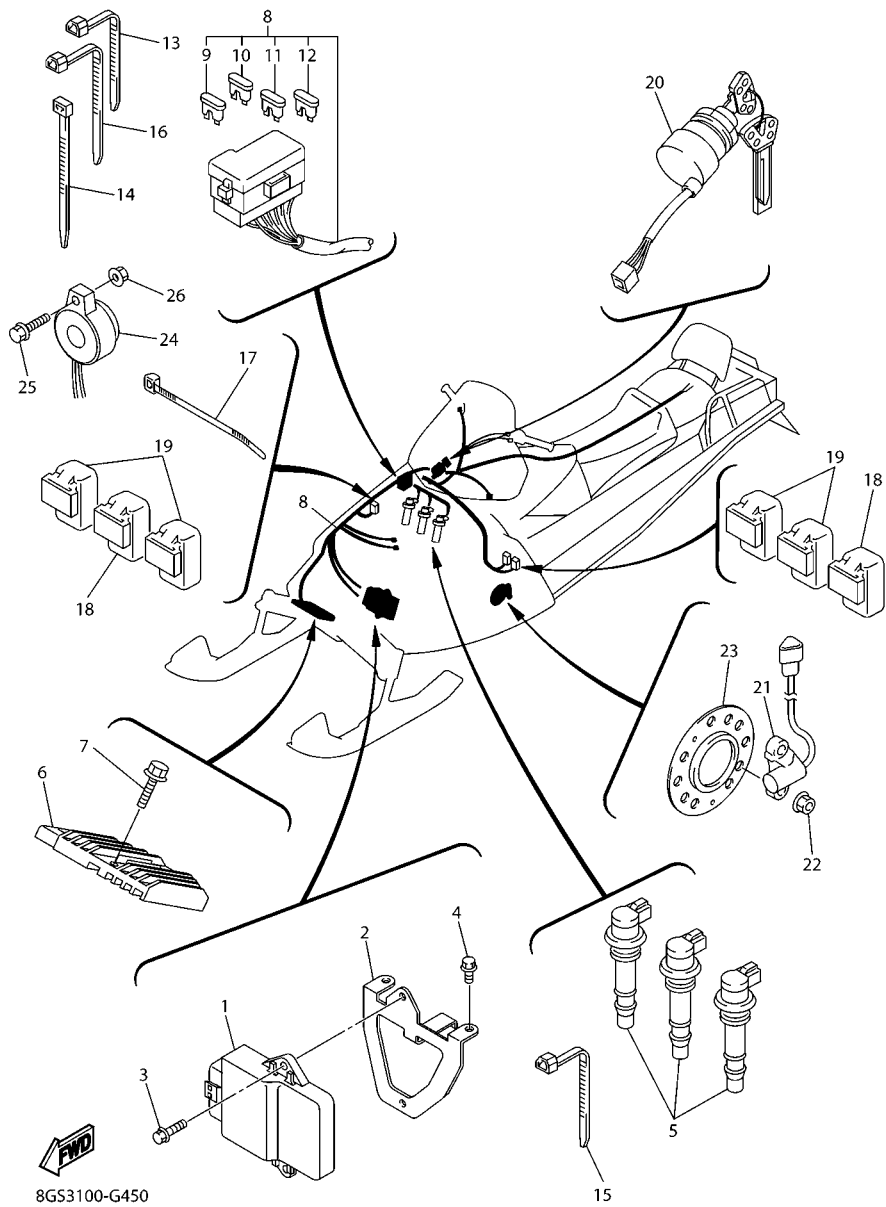
8GG3100-F420

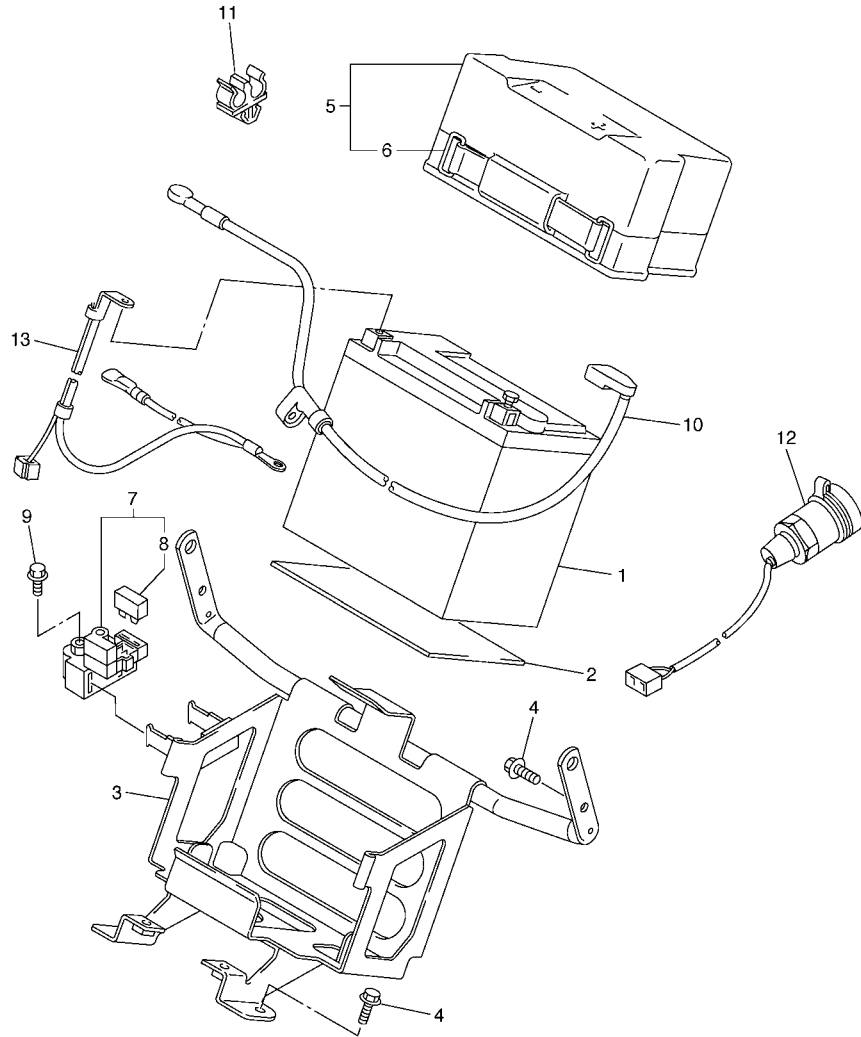
**FIG. 44 HANDLE SWITCH & LEVER**

REF. NO.	PART NO.	DESCRIPTION	8GS5	8GS6				REMARKS
1	8ES-82720-02	LEVER HOLDER ASSY (RIGHT)	1	1				
2	85G-83956-00	.CAP 1	2	2				
3	8R6-8399F-00	.SHAFT	1	1				
4	99001-04600	.CIRCLIP	1	1				
5	8FP-82558-00	.WASHER	2	2				
6	8FA-82970-01	.THUMB WARMER ASSY	1	1				
7	8FA-83973-01	SWITCH, HANDLE 3	1	1				
8	98502-05016	SCREW, PAN HEAD	2	2				
-----								
-----								
-----								
-----								
-----								
-----								
-----								
-----								
-----								
-----								
-----								
-----								

FIG. 45 ELECTRICAL 1

REF. NO.	PART NO.	DESCRIPTION	8GS5	8GS6	REMARKS
1	8FN-82305-00	IGNITOR UNIT ASSY	1	1	
2	8ES-85991-00	BRACKET, UNIT	1	1	
3	95822-06016	BOLT, FLANGE	2	2	
4	95822-06010	BOLT, FLANGE	2	2	
5	8ES-82310-00	IGNITION COIL ASSY	3	3	
6	5JW-81960-00	RECTIFIER & REGULATOR ASSY	1	1	
7	95880-06025	BOLT, FLANGE	2	2	
8	8GS-82590-01	WIRE HARNESS ASSY	1	1	
9	5JJ-82151-20	.FUSE (20A-BL)	3	3	
10	5JJ-82151-30	.FUSE (10A-BL)	2	2	
11	5JJ-82151-10	.FUSE (15A-BL)	3	3	
12	5JJ-82151-50	.FUSE (3A-BL)	2	2	
13	90464-15195	CLAMP	6	6	
14	90464-13073	CLAMP	4	4	
15	90464-12045	CLAMP	1	1	
16	90464-13077	CLAMP	2	2	
17	90464-35132	CLAMP	1	1	
18	5DM-81950-00	RELAY ASSY (G8HN-1C4T-DJ-Y52)	2	2	
19	8DM-81950-11	RELAY ASSY	4	4	
20	8FJ-82510-00	MAIN SWITCH ASSY	1	1	
21	8GK-83755-10	SENSOR, SPEED	1	1	
22	95702-08300	NUT, NYLON	4	4	
23	8EK-47551-00	HOUSING, FRONT AXLE	1	1	
24	8CW-83383-00	BUZZER	1	1	
25	90159-05035	SCREW, WITH WASHER	1	1	
26	95707-05500	NUT, FLANGE	1	1	





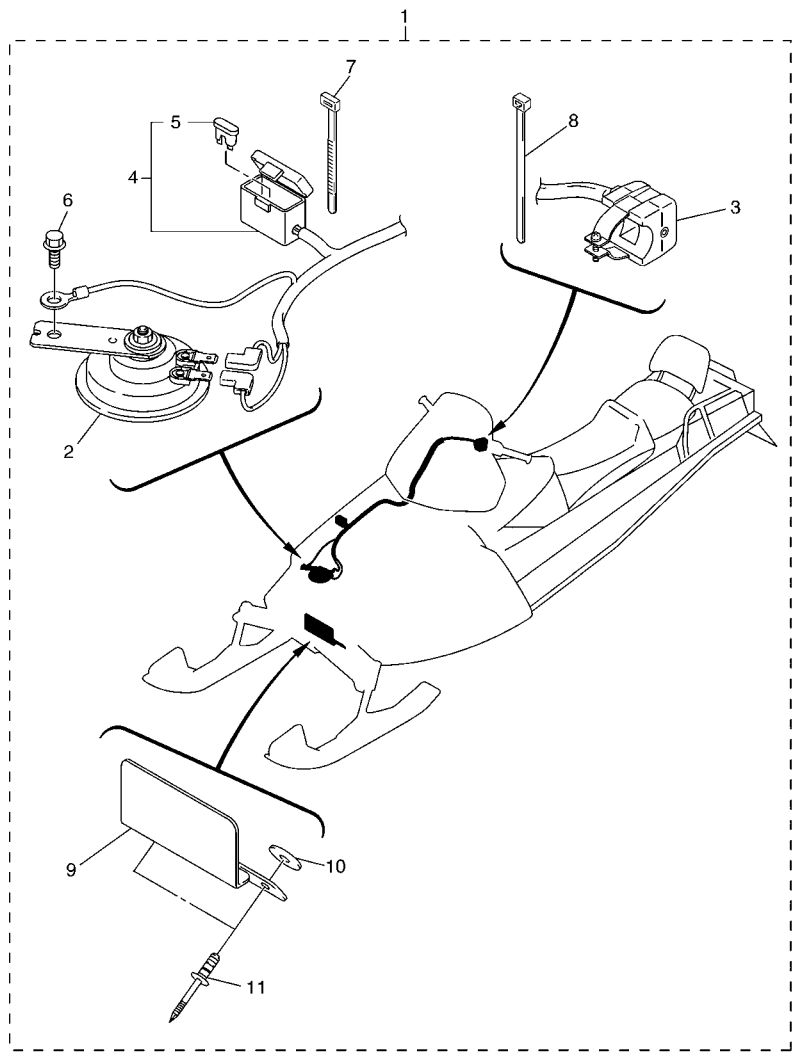
8FN1100-E450

FIG. 46 ELECTRICAL 2

REF. NO.	PART NO.	DESCRIPTION	8GS5	8GS6	REMARKS
1	4SH-82100-22	BATTERY ASSY (YUASA YTX20L-BS)	1	1	
2	8FA-82122-00	SEAT, BATTERY	1	1	
3	8FN-2199G-00	BRACKET, BATTERY	1	1	
4	95822-08016	BOLT, FLANGE	4	4	
5	8FA-82129-00	COVER, BATTERY	1	1	
6	8DM-82131-10	BAND, BATTERY	1	1	
7	4DN-81940-12	STARTER RELAY ASSY	1	1	
8	1AE-82151-00	FUSE (30A-BL)	2	2	
9	95022-06008	BOLT, FLANGE	2	2	
10	8FN-82115-00	WIRE, PLUS LEAD	1	1	
11	90464-08126	CLAMP	1	1	
12	8FP-8254B-00	TERMINAL COMP.	1	1	
13	8FN-82116-00	WIRE, MINUS LEAD	1	1	





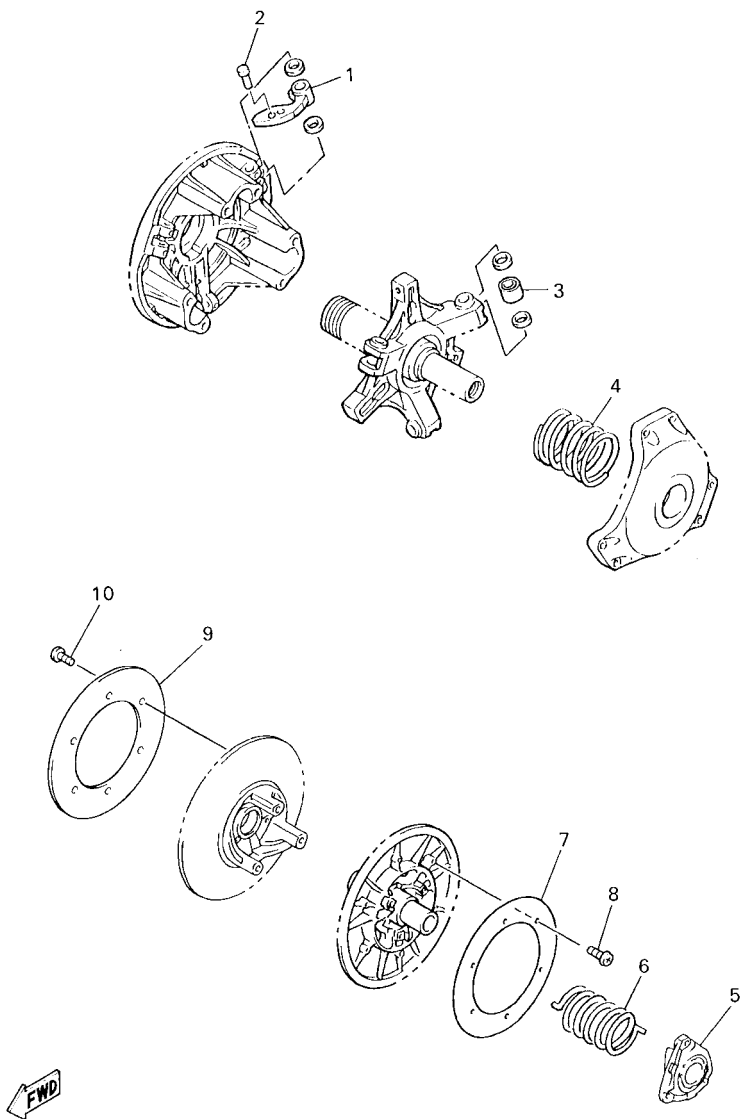


8GS3100-G480

FIG. 48 ELECTRICAL 4

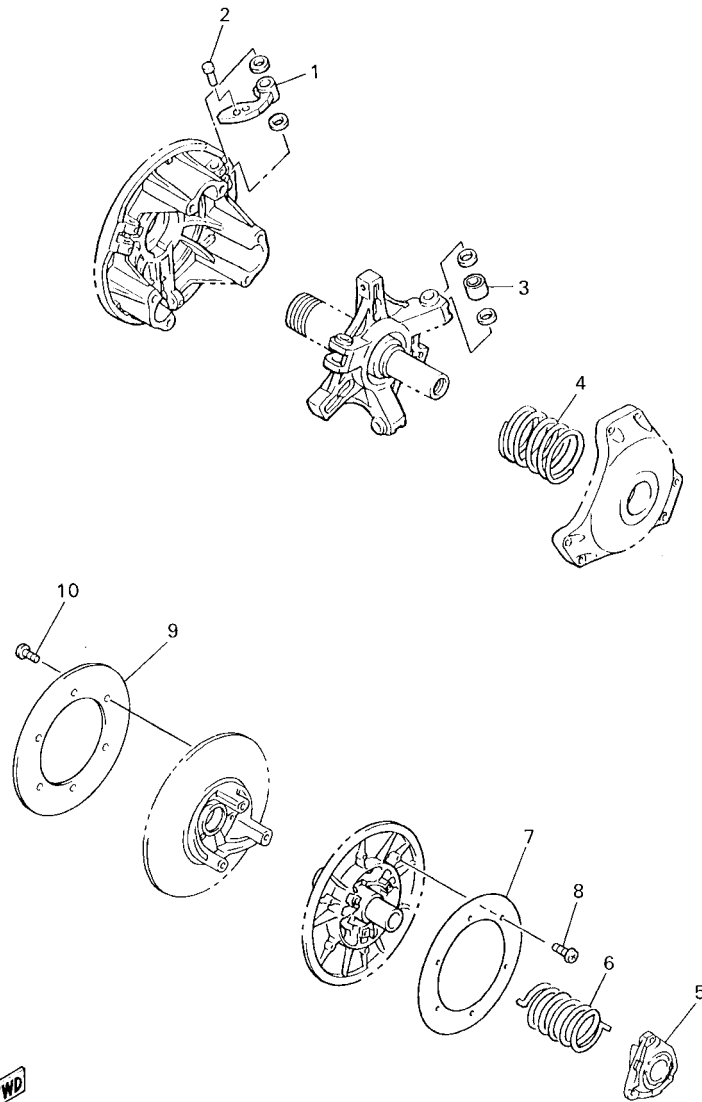
REF. NO.	PART NO.	DESCRIPTION	8GS5	8GS6	REMARKS
1	8GS-833A0-00	HORN KIT		1	FOR FINLAND
2	3MX-83371-11	.HORN		1	FOR FINLAND
3	8FR-83976-01	.SWITCH, HANDLE 1		1	FOR FINLAND
4	8GS-82509-00	.WIRE, SUB LEAD		1	FOR FINLAND
5	5JJ-82151-50	..FUSE (3A-BL)		1	FOR FINLAND
6	95822-06016	.BOLT, FLANGE		1	FOR FINLAND
7	437-83936-01	.BAND, SWITCH CORD		2	FOR FINLAND
8	90465-13152	.CLAMP		1	FOR FINLAND
9	8GU-21641-00	.BRACKET, REFLECTOR		1	FOR FINLAND
10	90201-05036	.WASHER, PLATE		2	FOR FINLAND
11	90267-47186	.RIVET, BLIND (4.7X16.4 BLACK)		2	FOR FINLAND

FIG. 49 ALTERNATE DRIVE SETTING 1



8CR3100-9470

REF. NO.	PART NO.	DESCRIPTION	8CS5	8CS6		REMARKS
1	8ES-17605-00	WEIGHT COMP	3	3		UR
	8DJ-17605-00	WEIGHT COMP	3	3		UR
	8BU-17605-20	WEIGHT COMP	3	3		UR
	8CH-17605-10	WEIGHT COMP	3	3		UR
	8DG-17605-00	WEIGHT COMP	3	3		UR
	8DN-17605-10	WEIGHT COMP	3	3		UR
	8FA-17605-10	WEIGHT COMP	3	3		UR
2	90261-06028	RIVET, COUNTERSUNK (AL10.3MM)	3	3		UR
	90266-06001	RIVET (AL13.3)	3	3		UR
	90261-06015	RIVET, COUNTERSUNK (ST10.3MM)	3	3		UR
	90266-06002	RIVET (ST13.3)	3	3		UR
	90261-06019	RIVET, COUNTERSUNK (ST13.3MM)	3	3		UR
	90261-06034	RIVET, COUNTERSUNK (ST13.9MM)	3	3		UR
	90269-06006	RIVET (ST17.2)	3	3		UR
	90261-06033	RIVET, COUNTERSUNK (ST17.2MM)	3	3		UR
3	8FG-17624-00	ROLLER, COMP	3	3		UR
	8FG-17624-10	ROLLER, COMP	3	3		UR
	8FG-17624-20	ROLLER, COMP	3	3		UR
	8FG-17624-30	ROLLER, COMP	3	3		UR
	8FG-17624-40	ROLLER, COMP	3	3		UR
4	90501-551L3	SPRING, COMPRESSION	1	1		UR (BL-P-BL)
	90501-583L5	SPRING, COMPRESSION	1	1		UR (WH-P-WH)
	90501-581L5	SPRING, COMPRESSION	1	1		UR (Y-P-Y)
	90501-581L6	SPRING, COMPRESSION	1	1		UR (GR-P-GR)
	90501-601L7	SPRING, COMPRESSION	1	1		UR (P-P-P)
	90501-601L8	SPRING, COMPRESSION	1	1		UR (OR-P-OR)
	90501-551L9	SPRING, COMPRESSION	1	1		UR (BL-SL-BL)

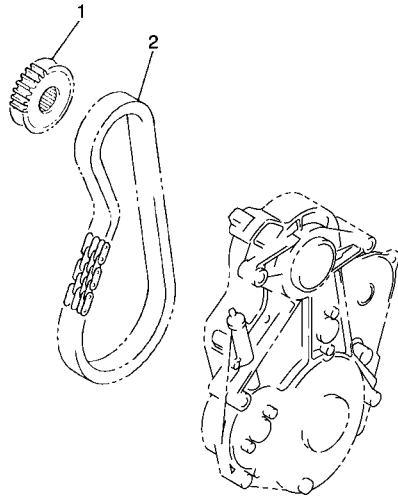


8CR3100-9470

FIG. 49 ALTERNATE DRIVE SETTING 1

REF. NO.	PART NO.	DESCRIPTION	8CS5	8CS6	REMARKS
4	90501-583L4	SPRING, COMPRESSION	1	1	UR (WH-SL-WH)
	90501-582L1	SPRING, COMPRESSION	1	1	UR (Y-SL-Y)
	90501-582L2	SPRING, COMPRESSION	1	1	UR (GR-SL-GR)
	90501-602L3	SPRING, COMPRESSION	1	1	UR (P-SL-P)
	90501-624L8	SPRING, COMPRESSION	1	1	UR (OR-SL-OR)
	90501-552L5	SPRING, COMPRESSION	1	1	UR (BL-GR-BL)
	90501-582L6	SPRING, COMPRESSION	1	1	UR (WH-GR-WH)
	90501-582L7	SPRING, COMPRESSION	1	1	UR (Y-GR-Y)
	90501-602L8	SPRING, COMPRESSION	1	1	UR (GR-GR-GR)
	90501-602L9	SPRING, COMPRESSION	1	1	UR (P-GR-P)
	90501-583L0	SPRING, COMPRESSION	1	1	UR (BL-WH-BL)
	90501-583L1	SPRING, COMPRESSION	1	1	UR (WH-WH-WH)
	90501-603L2	SPRING, COMPRESSION	1	1	UR (Y-WH-Y)
	90501-603L3	SPRING, COMPRESSION	1	1	UR (GR-WH-GR)
	90501-550A2	SPRING, COMPRESSION	1	1	UR (BL-BL-BL)
	90501-580A1	SPRING, COMPRESSION	1	1	UR (Y-BL-Y)
	90501-600A1	SPRING, COMPRESSION	1	1	UR (P-BL-P)
5	8BV-17604-11	SEAT SPRING SET	1	1	UR
	8BV-17604-31	SEAT SPRING SET	1	1	UR
	8BV-17604-51	SEAT SPRING SET	1	1	UR
	8BV-17604-71	SEAT SPRING SET	1	1	UR
	8BV-17604-91	SEAT SPRING SET	1	1	UR
	8FA-17604-00	SEAT SPRING SET	1	1	UR
6	90508-536A9	SPRING, TORSION	1	1	UR (RED)
	90508-556A2	SPRING, TORSION	1	1	UR (GREEN)
	90508-556A7	SPRING, TORSION	1	1	UR (SILVER)
	90508-500B1	SPRING, TORSION	1	1	UR (BROWN)

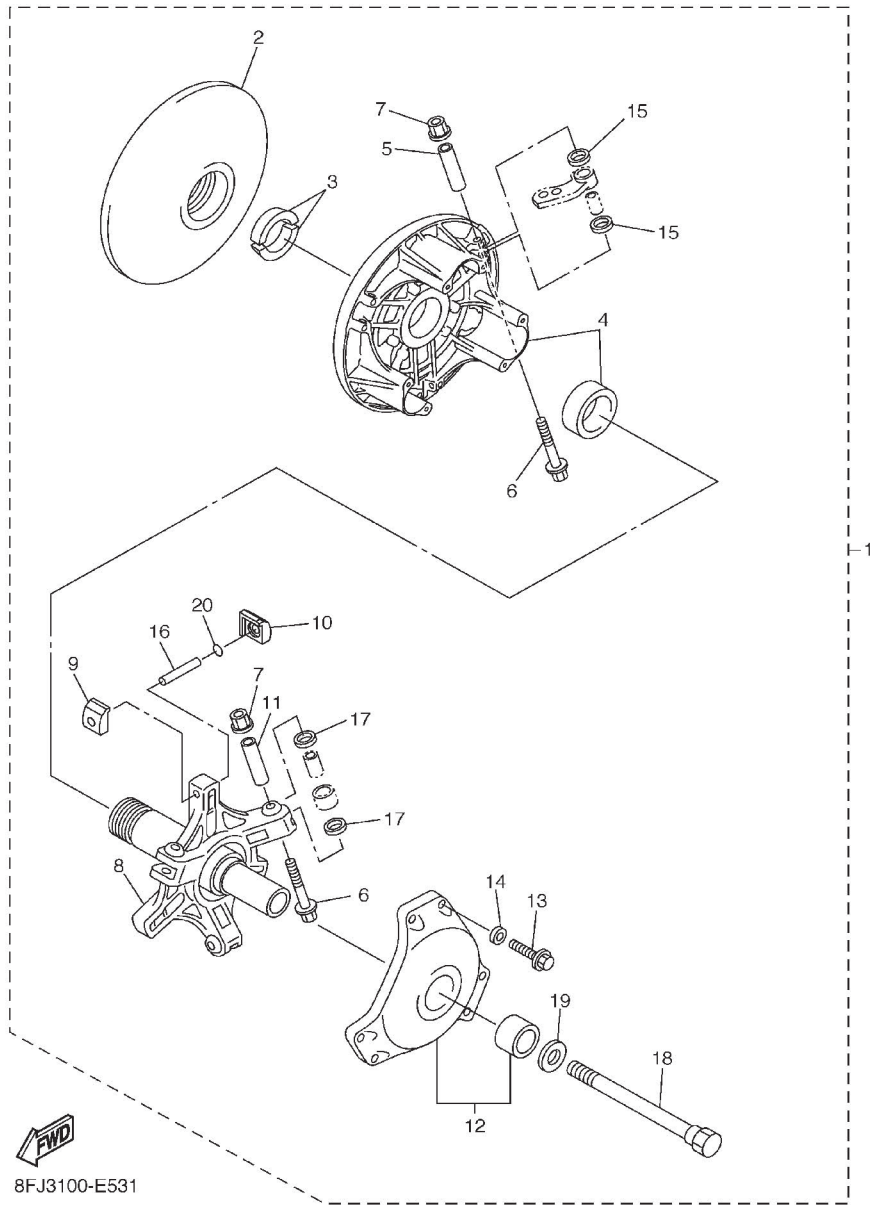




8GS1100-F490

**FIG. 50 ALTERNATE DRIVE SETTING 2**

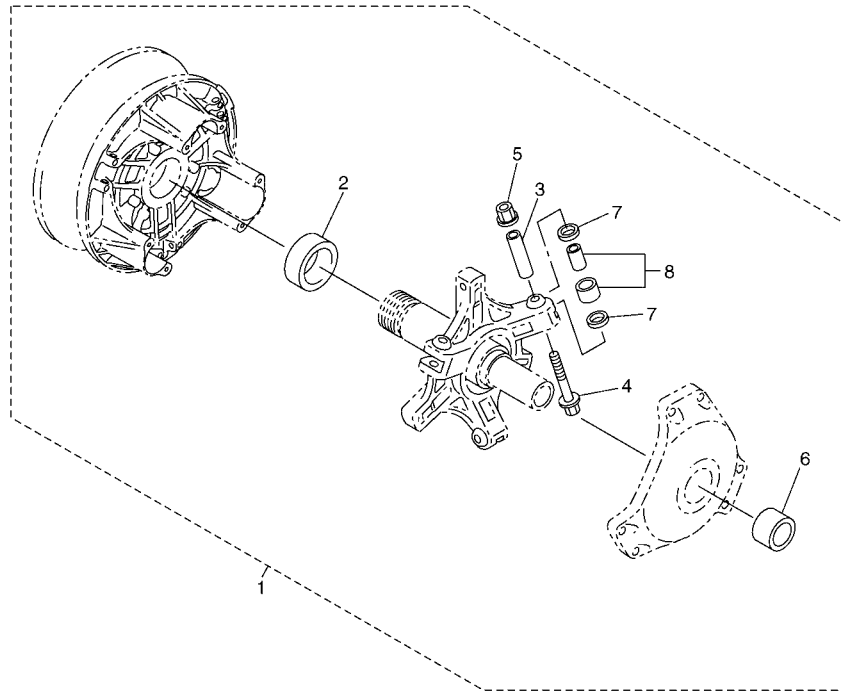
REF. NO.	PART NO.	DESCRIPTION	8GS5	8GS6				REMARKS
			1	1				
1	8FA-17682-90	SPROCKET, CHAIN DRIVE (19T)	1	1				UR
	8FA-17682-00	SPROCKET, CHAIN DRIVE (20T)	1	1				UR
	8FA-17682-10	SPROCKET, CHAIN DRIVE (21T)	1	1				UR
	8FA-17682-20	SPROCKET, CHAIN DRIVE (22T)	1	1				UR
	8FA-17682-30	SPROCKET, CHAIN DRIVE (23T)	1	1				UR
	8FA-17682-40	SPROCKET, CHAIN DRIVE (24T)	1	1				UR
2	94890-09068	CHAIN (68L)	1	1				UR
	94890-09070	CHAIN (70L)	1	1				UR



8FJ3100-E531

FIG. 51 ALTERNATE REBUILD KIT

REF. NO.	PART NO.	DESCRIPTION	8GS5	8GS6	REMARKS
1	8GS-W176G-01	CLUTCH REPAIR KIT	1	1	AP
2	8FA-17611-01	.SHEAVE, PRIMARY FIXED	1	1	
3	8V0-17639-00	.STOPPER	2	2	
4	8FP-17620-00	.PRIMARY SLIDING SHEAVE COMP.	1	1	
5	90387-0514T	.COLLAR	3	3	
6	90105-05644	.BOLT, FLANGE	6	6	
7	95607-05200	.NUT, U FLANGE	6	6	
8	8GS-17640-01	.SPIDER COMPLETE	1	1	
9	8BW-17653-00	.SLIDER	3	3	
10	8ES-17653-00	.SLIDER	3	3	
11	90387-0514U	.COLLAR	3	3	
12	8DF-17630-00	.PRIMARY SHEAVE CAP COMP.	1	1	
13	97017-06030	.BOLT	6	6	
14	92907-06600	.WASHER, PLATE	6	6	
15	90202-08204	.WASHER, PLATE	6	6	
16	91609-50032	.PIN, SPRING	3	3	
17	90202-09227	.WASHER, PLATE	6	6	
18	8V0-17647-00	.BOLT (L=156.5MM)	1	1	
19	92907-16100	.WASHER	1	1	
20	8ES-17655-00	.DAMPER, SLIDER	3	3	



8FA1100-B550

**FIG. 52 ALTERNATE CLUTCH TUNE UP KIT**

REF. NO.	PART NO.	DESCRIPTION	8CS5	8CS6		REMARKS
1	8FA-W176H-10	CLUTCH TUNE-UP KIT	1	1		AP
2	90384-41242	.BUSH, BIMETAL FORMED	1	1		
3	90387-0514U	.COLLAR	3	3		
4	90105-05644	.BOLT, FLANGE	3	3		
5	95607-05200	.NUT, U FLANGE	3	3		
6	90380-28237	.BUSH, SOLID	1	1		
7	90202-09227	.WASHER, PLATE	6	6		
8	8FG-17624-20	.ROLLER, COMP	3	3		



NUMERICAL INDEX

PART NO.	REF. NO.	PART NO.	REF. NO.	PART NO.	REF. NO.	PART NO.	REF. NO.	PART NO.	REF. NO.	PART NO.	REF. NO.	PART NO.	REF. NO.
8ES-11101-02	1 - 1	3LD-12168-A0	3 - 8	8FN-1244J-00	6 - 73	4JH-14121-00	10 - 27	8FA-14623-00	11 - 4	8GS-17110-01	31 - 83		
4KG-1111G-00	1 - 18	3LD-12168-F0	3 - 8	8ES-12450-01	5 - 7	8ES-14121-00	10 - 51	8ES-14627-00	11 - 7	8GS-17111-00	31 - 60		
5JW-11133-10	1 - 2	3LD-12168-H1	3 - 8	8ES-12459-01	5 - 9	4YR-14133-00	10 - 38	8FN-14637-00	11 - 9	8GS-1714A-01	31 - 70		
3P6-11134-10	1 - 3	3LD-12168-K1	3 - 8	8FN-12460-00	6 - 42	8ES-14146-00	22 - 13	8ES-14708-02	11 - 23	8GS-17210-00	31 - 81		
8ES-11181-00	1 - 19	3LD-12168-M1	3 - 8	8ES-12461-00	6 - 72	8ES-14147-00	10 - 6	8ES-14714-10	11 - 16	8GS-17243-01	31 - 76		
8ES-11191-01	1 - 12	3LD-12168-R1	3 - 8	3XP-12462-00	6 - 47	8ES-14148-00	9 - 29	8FA-14715-00	11 - 3	8CW-17492-00	31 - 77		
8ES-11193-00	1 - 14	3LD-12168-U1	3 - 8	8FN-12464-00	6 - 87	8ES-1414G-00	10 - 16	8FA-14737-00	11 - 20	8FA-17604-00	49 - 5		
8ES-11400-02	2 - 1	3LD-12168-W1	3 - 8	8FN-12467-00	6 - 57	8ES-14162-00	10 - 33	8FN-14750-00	11 - 19	8BV-17604-11	49 - 5		
8ES-11406-02	2 - 16	3LD-12168-Y1	3 - 8	8FN-12469-00	6 - 76	8ES-1417E-00	36 - 12	8FA-14788-00	11 - 17	8BV-17604-31	49 - 5		
8ES-11407-02	2 - 18	3LD-12169-11	3 - 8	8FN-12477-02	6 - 62	3TJ-14191-40	10 - 22	8ES-1478N-00	11 - 26	8BV-17604-51	49 - 5		
3LD-11416-10	2 - 6	3LD-12169-31	3 - 8	8ES-12482-00	6 - 1	8ES-14197-01	10 - 43	8ES-14900-02	10 - 1	8BV-17604-71	49 - 5		
3LD-11416-20	2 - 6	3LD-12169-50	3 - 8	8ES-12485-01	6 - 2	4JH-14216-00	10 - 10	8ES-14901-01	10 - 2	8FN-17604-90	16 - 11		
3LD-11416-30	2 - 6	3LD-12169-70	3 - 8	4TV-12486-00	10 - 50		10 - 10	8ES-14902-01	10 - 3	8BV-17604-91	49 - 5		
3LD-11416-40	2 - 6	3LD-12169-90	3 - 8	8FN-1248A-00	6 - 65	4YR-14216-00	10 - 47	8ES-14903-01	10 - 4	8DG-17605-00	49 - 1		
3LD-11416-50	2 - 6	3LD-12169-E0	3 - 8	8FN-1248E-00	6 - 68	4JH-14264-00	10 - 31	8ES-14916-00	10 - 14	8DJ-17605-00	49 - 1		
3LD-11416-60	2 - 6	3LD-12169-G0	3 - 8	8FW-1249A-00	6 - 9	8ES-14283-00	9 - 26	4TV-14926-00	10 - 26	8ES-17605-00	49 - 1		
3LD-11416-70	2 - 6	3LD-12169-J0	3 - 8	8FN-12577-00	6 - 4	8ES-14294-00	9 - 4	8ES-14926-01	10 - 24	8FN-17605-00	15 - 25		
8ES-11428-01	2 - 25	3LD-12169-L0	3 - 8	8ES-12578-00	6 - 17	8ES-14294-10	9 - 4	8ES-14933-00	10 - 11	8CH-17605-10	49 - 1		
8ES-11454-00	2 - 21	3LD-12169-N0	3 - 8	8FN-12579-00	6 - 11	8ES-14295-00	10 - 40	4YR-14934-00	10 - 52	8DN-17605-10	49 - 1		
59J-11455-00	2 - 15	3LD-12169-T0	3 - 8	8FN-12580-00	6 - 24	8ES-14298-00	9 - 6	8ES-14935-00	10 - 32	8FA-17605-10	49 - 1		
8ES-11464-00	2 - 28	8ES-12170-01	4 - 1	8ES-12588-00	6 - 19	8ES-14298-10	9 - 6	4JH-14936-00	10 - 13	8BU-17605-20	49 - 1		
8ES-11478-00	2 - 26	8ES-12176-00	4 - 2	8FN-12589-00	6 - 21	4JH-14358-00	10 - 34	3TJ-14937-40	10 - 44	8FA-17611-01	15 - 1		
8ES-11530-00	2 - 19	8ES-12210-01	4 - 5	8FN-12590-00	6 - 46	8ES-14419-00	9 - 23	8ES-14940-00	10 - 12		51 - 2		
5JW-11603-00	2 - 8	4FM-12213-00	4 - 6	8ES-13115-00	7 - 15	8ES-1441A-00	9 - 22	3TJ-14943-36	10 - 17	8GS-1761A-00	31 - 15		
8ES-11631-00	2 - 7	5BE-12241-00	1 - 13	8FN-1319B-02	7 - 13	8ES-14425-00	9 - 20	3TJ-14943-37	10 - 17	8GS-1761E-00	31 - 18		
5JW-11633-00	2 - 10	8ES-12251-00	4 - 8	8ES-13284-00	7 - 5	8ES-14427-00	9 - 31	3TJ-14943-87	10 - 17	8FP-17620-00	15 - 3		
5JW-11650-01	2 - 2	8ES-12252-00	4 - 9	8ES-13300-00	7 - 1	8ES-14431-00	9 - 15	8ES-14947-00	10 - 15		51 - 4		
5JW-11654-00	2 - 3	8FP-12405-00	6 - 71	4XV-13355-00	7 - 2	8FA-14436-00	9 - 19	8ES-14948-03	10 - 18	8FG-17624-00	49 - 3		
5JW-11656-00	2 - 5	8FN-12405-01	6 - 43	8FG-13406-00	18 - 2	8ES-14441-00	9 - 16	8ES-14948-05	10 - 18	8FG-17624-10	49 - 3		
5JW-11656-10	2 - 5	8FN-12410-00	6 - 26	8ES-13414-01	8 - 4	8ES-14451-00	9 - 18	8ES-14948-06	10 - 18	8FG-17624-20	15 - 22		
5JW-11656-20	2 - 5	8EK-12412-00	6 - 27	8ES-13416-00	1 - 21	8ES-14452-00	9 - 21	8ES-14948-07	10 - 18		49 - 3		
5JW-11656-30	2 - 5	5EB-12413-00	6 - 25	8ES-13417-00	8 - 2	8ES-14453-00	9 - 24	8ES-14958-00	10 - 9		52 - 8		
5JW-11656-40	2 - 5	8ES-12420-02	5 - 1	8ES-13427-00	7 - 4	8ES-14454-00	10 - 48	8ES-14965-00	10 - 35	8FG-17624-30	49 - 3		
5JW-11656-A0	2 - 5	8ES-12422-00	5 - 2	5DM-13440-00	8 - 1	8FN-14472-00	9 - 17	8ES-14984-00	10 - 21	8FG-17624-40	49 - 3		
5JW-12111-00	3 - 1	8ES-12427-00	5 - 3	8FN-13464-00	7 - 10	4JH-14487-00	10 - 39	8ES-14985-00	10 - 20	8DF-17630-00	15 - 17		
5JW-12113-00	3 - 4	8ES-12434-00	5 - 13	8ES-13470-01	8 - 9	4TV-14534-00	10 - 56	8ES-14987-00	10 - 49		51 - 12		
5JW-12116-00	3 - 3	8ES-12435-00	5 - 12	5JW-13473-00	8 - 10	676-14548-00	10 - 19	8FA-15113-00	39 - 4	8V0-17639-00	15 - 2		
5JW-12117-00	3 - 5	8ES-12436-00	5 - 17	8FN-13520-00	18 - 13	7A9-14555-00	10 - 28	8ES-15167-00	12 - 3		51 - 3		
1AA-12118-00	3 - 6	8ES-12438-00	5 - 4	8ES-13586-10	9 - 1	4YR-14557-00	10 - 57	8ES-1531A-00	13 - 12	8GS-17640-01	15 - 9		
5JW-12121-01	3 - 2	8FN-1243A-00	6 - 74	8ES-13815-00	10 - 41	8ES-14561-00	10 - 29	3Y1-15361-00	31 - 39		51 - 8		
3P6-12129-00	3 - 7	8FN-1243E-00	6 - 6	8ES-13816-00	10 - 42	4TV-14562-00	10 - 46	3Y1-15363-00	1 - 15	8GS-17641-00	15 - 30		
5EB-12153-09	3 - 9	8FN-1243F-00	6 - 75	8ES-13892-00	9 - 12	8ES-14565-00	10 - 30	4JT-15381-01	2 - 22	8V0-17647-00	15 - 31		
5EB-12153-10	3 - 9	8FN-12440-00	19 - 55	8ES-13895-00	9 - 10	8ES-14567-00	10 - 37	8ES-15421-01	13 - 1		51 - 18		
3LD-12168-00	3 - 8	8FN-12443-00	9 - 37	8ES-13898-00	7 - 19	8ES-14578-00	10 - 36	8ES-15461-01	13 - 6	8BW-17653-00	15 - 10		
3LD-12168-20	3 - 8	8FN-1244E-00	6 - 52	8FA-13910-00	9 - 32	8ES-14592-00	10 - 25	8ES-15512-01	14 - 2		51 - 9		
3LD-12168-40	3 - 8	8FN-1244F-00	6 - 86	8ES-146105-00	10 - 5	8ES-14610-00	11 - 13	8FA-15515-00	14 - 1	8ES-17653-00	15 - 11		
3LD-12168-60	3 - 8	8FN-1244G-00	6 - 40	8ES-14107-00	10 - 8	8ES-14613-00	11 - 2	8ES-15521-00	14 - 3		51 - 10		
3LD-12168-80	3 - 8	8FN-1244H-00	6 - 48	8ES-1410A-00	10 - 7	8ES-14615-01	11 - 1	8GL-15590-00	14 - 4	8ES-17655-00	15 - 13		

NUMERICAL INDEX

PART NO.	REF. NO.	PART NO.	REF. NO.	PART NO.	REF. NO.	PART NO.	REF. NO.	PART NO.	REF. NO.	PART NO.	REF. NO.
8ES-17655-00	51 - 20	8FN-21926-00	19 - 27	8FN-2199G-00	46 - 3	8GS-23870-00	22 - 1	8FN-24750-01	24 - 4	8GS-47331-00	28 - 12
8BV-17656-00	16 - 3	8FN-21933-01	19 - 85	4AA-22259-40	28 - 30	8FA-23872-00	21 - 18	8FN-2476U-00	24 - 19	8GS-47332-00	28 - 48
8CR-17660-20	16 - 1	8FN-21936-00	19 - 28		28 - 64	8FN-23872-00	21 - 22	8FN-24772-00	36 - 26	8FM-47333-00	29 - 6
8CM-17665-00	49 - 7	8FN-21939-00	19 - 38	4AA-22259-50	28 - 30	8FA-23873-00	21 - 11	8FN-2478C-00	36 - 23	83R-47335-00	29 - 21
8BU-17670-20	16 - 5	8CR-21939-01	19 - 37		28 - 64	1UY-23894-01	21 - 24	8FN-2478E-00	36 - 32	8FN-47336-00	28 - 97
8CM-17675-00	49 - 9	8GS-2193A-00	19 - 12	4AA-22259-60	28 - 30	8FA-2389C-E0	22 - 5	8FN-24790-00	24 - 6	8FN-47336-10	28 - 97
8GS-17681-00	16 - 14	8FN-2193E-00	19 - 51		28 - 64	8FA-2389C-J0	22 - 5	8ET-24796-00	24 - 14	8FN-47336-20	28 - 97
8FA-17682-00	31 - 54	8GS-21940-10	19 - 1	3YK-22472-40	20 - 28	8FA-2389C-S0	22 - 5	3AC-24877-C0	24 - 10	83R-47337-00	29 - 1
	50 - 1	8CW-21943-00	19 - 31	8ED-23442-00	21 - 4	8FA-2389E-00	6 - 45	4KN-24877-C0	37 - 31	8AC-47341-00	28 - 9
8FA-17682-10	50 - 1	8GS-21943-00	19 - 42	8ES-23501-00	20 - 18		22 - 9	8FN-24897-00	24 - 9	8AC-47349-00	28 - 96
8FA-17682-20	50 - 1	8FN-21944-01	19 - 23	8ES-23502-00	20 - 54	8FN-2389K-00	21 - 33	8FM-24897-01	37 - 31	8AC-47366-00	28 - 80
8FA-17682-30	50 - 1	8FN-21947-00	19 - 10	8FN-23540-00	20 - 29	8FN-2389M-00	21 - 35	8FN-24897-10	24 - 9	8DF-47367-00	28 - 93
8FA-17682-40	50 - 1	8FN-21949-00	19 - 73	8FN-23550-00	20 - 60	8FN-24111-01	23 - 1	8FM-24897-11	37 - 31	8FN-47377-00	30 - 7
8FA-17682-90	50 - 1	8FN-2194E-00	19 - 52	8FN-23570-00	20 - 38	8FN-24111-10	23 - 1	8FU-2580T-01	25 - 7	8AC-47411-10	28 - 1
8AV-17688-10	16 - 2	8FN-2194F-00	19 - 16	8FN-23580-00	20 - 62	8FN-24114-00	23 - 13	8FU-2581T-00	25 - 1	8AC-47414-10	28 - 7
8FB-17692-00	31 - 67	8FN-2194G-00	19 - 17	8FN-23711-00	20 - 1	8FA-2412G-00	21 - 40	55U-25854-00	25 - 21	8AC-47416-01	28 - 41
8GS-18104-01	32 - 8	8FN-2194H-00	19 - 26	8DM-23712-00	20 - 2	8HF-2412G-00	21 - 25	8AC-25867-00	25 - 28	8AC-47417-01	28 - 56
8GS-18115-00	31 - 25	8FN-2194N-00	36 - 29	8EN-23731-01	20 - 4	8AC-2414B-01	34 - 5	8GS-25872-01	25 - 14	8AC-47418-00	28 - 36
8GS-18128-01	32 - 19	8FN-2194R-00	36 - 31	8ES-23743-00	20 - 16	8FN-2414E-00	36 - 28	8CR-2589F-00	25 - 23	8CM-47419-10	27 - 2
8GS-18152-01	32 - 10	8GS-21950-01	19 - 20	8EM-23744-00	20 - 17	8FN-2414G-00	36 - 11	8FU-25919-00	25 - 11		
2H9-18154-00	31 - 24	8FN-21953-00	19 - 43	8EK-23751-00	20 - 5	8FN-24181-00	22 - 3	8FU-25924-00	25 - 12	8AC-47421-00	28 - 2
3X3-18157-10	31 - 28	8FN-21954-01	19 - 24	8EX-23754-00	20 - 3	8GS-24181-00	23 - 22	8FU-25970-01	25 - 32	8ED-47422-00	28 - 4
8GS-18161-01	32 - 5	8FN-21959-00	19 - 74	83R-23768-00	29 - 19	8FN-24182-00	22 - 4	8FN-26110-00	21 - 1	8AC-47424-00	29 - 4
8GS-18164-00	32 - 1	8FU-2195E-01	19 - 62	8FN-2376A-00	20 - 48	8GS-24182-00	23 - 23	8DM-26240-01	26 - 4	83R-47446-00	29 - 22
8GS-18174-00	32 - 17	8FU-2195F-01	19 - 63	8FN-2376H-00	21 - 19	8FN-2418A-00	23 - 20	4SV-26280-00	33 - 39	8CR-47448-00	28 - 23
8GS-18179-01	32 - 23	8FN-21960-01	19 - 49	8ES-23803-00	20 - 23	8FN-241A3-00	36 - 20	4SV-26290-00	33 - 40	8FN-47456-00	28 - 13
8GS-18191-00	31 - 23	8FN-21962-01	19 - 29	8FA-23811-00	21 - 9		36 - 35	8FN-26311-00	26 - 1	8AC-47457-00	28 - 8
8GS-18511-00	31 - 85	8FN-21963-01	19 - 30	8FA-23812-00	21 - 20	8FN-241A4-00	36 - 21	8FN-26330-00	26 - 2	8AX-47458-00	28 - 10
8GS-18531-00	31 - 86	8GS-21965-00	19 - 33	8FA-23813-01	21 - 2	8FN-241A5-00	19 - 90	8FN-26351-10	25 - 38	8AC-4745A-10	28 - 83
8GS-18541-01	31 - 22	8GS-21966-00	19 - 34	8K1-23814-00	21 - 3	8CR-24301-00	23 - 4	4NO-27114-00	38 - 3	8CR-4745B-00	28 - 84
8FA-2139X-00	12 - 5	8ES-2196A-00	19 - 64	8FN-23815-00	22 - 12	8FN-24311-00	23 - 14	8FA-27114-00	24 - 18	8DF-47463-01	28 - 37
8ES-21410-00	17 - 1	8FA-2196E-00	19 - 65	8FA-23818-02	21 - 10	8GS-24311-00	23 - 14	8DM-27431-02	19 - 82	8DF-47464-01	28 - 38
8ES-21420-00	17 - 2	8FA-2196F-00	19 - 67	8FK-2381B-00	21 - 6	8FN-24311-10	23 - 15	8DM-27441-02	19 - 83	8GS-47465-00	28 - 17
8ES-21459-00	12 - 6	8FG-2196M-00	19 - 39	8FA-23821-00	21 - 32	8GS-24311-10	23 - 15	8FN-28100-01	36 - 1	83R-47469-00	27 - 20
8FN-21481-00	17 - 4	8FN-2196T-00	36 - 22	8FN-23826-00	21 - 42	8FA-24335-00	23 - 8	8GS-2815J-E0	9 - 30	8AC-47475-00	28 - 49
8FG-21495-00	17 - 8	8GS-21970-00	19 - 50	8FN-23828-00	21 - 27	8FA-24491-00	9 - 33	8GS-2815J-J0	9 - 30	8AC-47478-00	29 - 24
8FG-2149C-00	17 - 9	8FA-21972-01	19 - 66	8FN-23831-00	21 - 46	8H5-24560-00	23 - 6	8GS-2815J-S0	9 - 30	8DM-47479-00	27 - 28
8FN-21557-00	19 - 87	8FN-21973-00	36 - 7	8FA-23843-00	21 - 26	8FG-24610-00	23 - 2	8ET-2815K-00	34 - 9	8FN-47480-30	28 - 63
8GU-21641-00	48 - 9	8FR-2197E-00	19 - 80	8CR-23845-10	21 - 29	8FG-24641-00	23 - 3	8ET-2815K-10	34 - 10	8FN-47480-40	28 - 63
8ES-21745-00	18 - 14	8ES-2197H-01	33 - 27		21 - 47	8FN-2470F-02	24 - 2	4B5-2815K-20	35 - 2	8FN-47480-50	28 - 63
8ES-2174N-00	18 - 16	8FG-2197M-00	19 - 40	8CR-23847-00	21 - 28	8FN-2470H-01	24 - 5	8AC-4631K-00	28 - 65	8FN-47481-30	28 - 29
8FG-21751-02	18 - 1	8FN-2198E-00	19 - 15	8FA-23847-00	21 - 48	8FN-24710-02	24 - 1	8FN-47481-40	27 - 1	8FN-47481-40	28 - 29
89A-21815-00	6 - 33	8FN-2198F-00	19 - 88	8FA-2384N-00	21 - 39	8FN-24723-00	36 - 24	8ES-47310-00	27 - 7	8FN-47481-50	28 - 29
8FN-21816-00	18 - 18	8FU-2198F-00	19 - 60	8FN-23851-00	20 - 25	8FN-24742-00	36 - 36		27 - 11	83R-47485-02	28 - 19
8FN-21851-00	6 - 58	8FU-2198G-00	19 - 41	8FN-23852-00	20 - 59	8FN-2474A-00	24 - 11		27 - 38		28 - 58
8FN-21871-00	6 - 32	8GS-2198H-00	33 - 28	8DF-23857-00	21 - 5	8GS-2474B-00	24 - 13	8FM-47310-00	27 - 21	8FN-47486-00	27 - 10
8FN-21912-00	33 - 26	8FU-2198J-00	19 - 61	8FA-23867-00	21 - 21	8FN-2474H-00	24 - 17	8AC-47310-10	28 - 82	8FN-47488-00	28 - 42
8EK-21920-01	19 - 59	8FA-21999-00	19 - 44	8FN-23867-00	21 - 12	8FN-2474W-00	24 - 12	8AC-47320-00	27 - 15	8FN-47489-00	28 - 98

NUMERICAL INDEX

PART NO.	REF. NO.	PART NO.	REF. NO.	PART NO.	REF. NO.	PART NO.	REF. NO.	PART NO.	REF. NO.	PART NO.	REF. NO.
8CR-47494-01	28 - 72	8FN-7715A-00	34 - 4	8FN-77761-R1	34 - 7	8GS-82590-01	45 - 8	8ES-85991-00	45 - 2	90105-08072	21 - 7
8CV-47495-00	28 - 25	8FN-77161-00	33 - 15	8GS-77761-R1	34 - 6	8ES-82720-02	44 - 1	8FN-F3711-00	20 - 1	90105-081A7	22 - 6
8GS-47511-00	30 - 1	8FN-77162-00	33 - 16	8DM-77761-S0	34 - 6	8ET-82917-00	36 - 17	8DM-F3712-00	20 - 2	90105-08450	28 - 40
83R-47520-10	27 - 19	8FA-77167-10	33 - 14	8FN-77761-S0	34 - 7	8CN-82917-01	6 - 88	8EN-F3731-01	20 - 4	90105-08483	29 - 17
8FN-47532-00	30 - 4	8FN-77171-00	38 - 8	8BD-77762-00	36 - 10	8FA-82970-01	44 - 6	8EK-F3751-00	20 - 5	90105-08552	21 - 15
8GS-47541-00	31 - 1	8FN-77210-00	35 - 5	8BD-77762-01	36 - 10	3MX-83371-11	48 - 2	8EX-F3754-00	20 - 3	90105-10096	25 - 17
8GS-47543-00	31 - 32	82H-77223-00	35 - 6	8BD-77762-21	36 - 10	8CW-83383-00	45 - 24	8FN-K7210-00	35 - 5	90105-10105	28 - 78
8GS-47546-00	31 - 52	8FN-77251-00	35 - 1	8AC-77762-R1	36 - 10	8GS-833A0-00	48 - 1	8CR-W0041-00	25 - 19	90105-10106	20 - 11
8AC-47550-00	27 - 18	8FN-77261-00	6 - 61	8GS-77763-E0	34 - 8	8FN-83500-01	41 - 1	8FA-W0045-00	25 - 33	90105-10151	24 - 8
8CR-47550-10	27 - 24	8FN-77262-00	36 - 18	8GS-77763-J0	34 - 8	4XV-83513-00	41 - 9	8FU-W0046-01	25 - 10		24 - 16
8EK-47550-10	27 - 25	8FN-77263-00	36 - 19	8GS-77763-S0	34 - 8	4WM-83517-00	41 - 2	3JD-W0047-10	25 - 9	90105-10223	31 - 64
8EK-47551-00	45 - 23	8FN-77264-00	33 - 6	8ES-81410-00	39 - 1	4WM-83517-10	41 - 3	8CR-W0048-00	25 - 13	90105-10232	20 - 49
8GS-47554-01	31 - 31	8FN-77271-00	33 - 3	8ES-81450-01	39 - 6	5PW-8352S-00	41 - 6	8FU-W0057-00	25 - 8	90105-10392	20 - 50
8GS-47558-00	31 - 8	8FN-77272-00	33 - 4	8ES-81517-01	10 - 55	8EK-8353E-01	41 - 4	8ES-W1510-04	12 - 1	90105-103A1	28 - 18
8GS-47564-00	31 - 80	8FN-77273-00	33 - 5	2S3-81801-00	40 - 2	8EK-83572-01	41 - 5	8GS-W176G-01	51 - 1		28 - 47
8GS-47571-00	31 - 75	8ES-77276-00	33 - 30	8FA-8181L-00	40 - 5	8FA-83614-00	6 - 56	8FA-W176H-10	52 - 1		28 - 52
8GS-47578-00	36 - 11	8GS-77277-00	33 - 31	2S3-8182G-00	40 - 3	8GK-83755-10	45 - 21	8GS-W2195-00	19 - 36	90105-10433	27 - 14
8GS-47587-90	31 - 58	8FA-77311-02	36 - 2	1D7-81835-00	40 - 6	5FU-83790-20	10 - 53	8FN-W2197-00	19 - 2		28 - 22
8CW-47591-00	31 - 16	8CR-77319-00	36 - 8	8ES-8183G-00	40 - 12	8CR-83912-00	25 - 24	8FN-W2198-00	19 - 5		28 - 39
8GS-47591-00	31 - 19	8CR-77338-00	36 - 3	8ES-81846-01	40 - 9	8DN-83912-00	25 - 24	8CR-W2585-00	25 - 20		28 - 57
8ES-47613-00	31 - 47	8FA-77373-00	36 - 5	5PX-81861-00	40 - 8	8FA-83922-00	25 - 39	3GM-W2585-21	25 - 20	90105-10436	28 - 76
8FN-47631-00	16 - 15	8CR-77384-01	6 - 44	8GL-81890-00	40 - 1	437-83936-01	48 - 7	8EN-W2587-00	25 - 18	90105-10549	21 - 13
8EK-47715-00	30 - 8		36 - 6	4DN-81940-12	46 - 7	85G-83956-00	44 - 2	8EN-W2587-10	25 - 18	90105-10739	28 - 75
8FN-77108-00	33 - 11	8FN-77390-00	36 - 13	5DM-81950-00	45 - 18	8FA-83973-01	44 - 7	8CR-W2628-10	33 - 38	90105-10N51	20 - 31
8FN-77109-00	33 - 10	8FN-77511-00	37 - 1	8DM-81950-11	45 - 19	8FR-83976-01	48 - 3	8FM-W4741-10	29 - 2	90105-10N54	20 - 34
8FN-77111-00-P2	33 - 1	8FN-77512-00	19 - 71	5JW-81960-00	45 - 6	8CR-8398X-00	25 - 26		29 - 3	90105-10N55	20 - 43
8FN-77111-00-P3	33 - 1	8FN-77523-00	37 - 3	4SH-82100-22	46 - 1	8R6-8399F-00	44 - 3	8FN-W4753-00	30 - 2	90105-12017	21 - 38
		8FN-77524-00	37 - 4	8FA-82103-00	10 - 54	8FN-8399N-00	42 - 9	8FN-W7726-00	33 - 2	90105-12032	2 - 13
8FN-77118-00	33 - 18	8FN-77541-00	37 - 7	8FN-82115-00	46 - 10	8DN-84310-01	42 - 1	90101-06047	31 - 30	90105-12N54	20 - 40
8FN-7711L-30	34 - 2	8FN-77542-00	37 - 11	8FN-82116-00	46 - 13	8G9-84314-00	42 - 2	90101-08774	27 - 9	90105-14003	31 - 89
8FN-7711L-40	34 - 2	8FN-77543-00	37 - 14	8FA-82122-00	46 - 2	8A5-84331-00	42 - 6		27 - 40	90105-14766	16 - 25
		8FN-77544-00	37 - 15	8FA-82129-00	46 - 5	8A5-84332-00	42 - 7	90101-10357	31 - 9	90109-06015	8 - 5
8FN-7711M-30	34 - 3	8FN-77551-00	37 - 20	8DM-82131-10	46 - 6	8FN-84359-00	42 - 10	90101-10738	28 - 33		13 - 10
8FN-7711M-40	34 - 3	8FN-77552-00	37 - 22	1AE-82151-00	46 - 8	8DS-84366-00	33 - 7	90102-10044	21 - 43	90109-06031	8 - 7
		8FN-77553-00	37 - 25	5JJ-82151-10	45 - 11	8K4-84374-00	42 - 5		21 - 51	90109-06081	8 - 6
8FN-77130-00	33 - 8	8FN-77554-00	37 - 26	5JJ-82151-20	45 - 9	8DN-84397-01	42 - 3	90105-05644	15 - 7	90109-06174	37 - 21
8FN-77131-00	38 - 4	8FA-77561-00	33 - 36	5JJ-82151-30	45 - 10	8FN-84710-00	43 - 1		15 - 15	90109-06185	12 - 12
8FN-77132-00	38 - 5	8FA-77562-00	33 - 37	5JJ-82151-50	45 - 12	1A2-84714-41	43 - 2		51 - 6	90109-06187	4 - 10
8FN-77133-00	36 - 14	80M-77591-00	37 - 34		48 - 5	8FN-84717-00	43 - 6		52 - 4	90109-066F0	1 - 17
8FN-77134-00	33 - 9	86D-77591-00	37 - 40	8FN-82305-00	45 - 1	8FP-85075-00	18 - 8	90105-06026	1 - 7	90110-05034	39 - 3
8FA-77135-00	33 - 25	84R-77592-00	37 - 38	8ES-82310-00	45 - 5	8GM-85110-00	47 - 1	90105-06066	7 - 3	90110-06043	36 - 27
8FN-77140-00	33 - 21	83R-77595-00	37 - 32	8FN-82509-00	6 - 89		47 - 7	90105-060A6	23 - 12	90110-06164	8 - 11
8GS-77141-10	34 - 1	8FN-77711-00	38 - 1	8GS-82509-00	48 - 4	3Y6-85130-02	47 - 4		31 - 17	90110-06168	14 - 5
8GS-77141-20	34 - 1	8GS-77735-00	38 - 6	8FJ-82510-00	45 - 20		47 - 7		31 - 73	90110-06187	39 - 5
		8DM-77761-E0	34 - 6	8CR-82530-01	25 - 25	8FA-85720-01	18 - 7	90105-06123	12 - 15	90110-06211	31 - 61
8U1-77157-00	37 - 42	8FN-77761-E0	34 - 7	5LP-82540-01	31 - 40	8GS-85752-00	23 - 9	90105-06734	16 - 8	90110-06223	39 - 2
89A-77159-00	24 - 3	8BY-77761-J0	34 - 6	8FP-8254B-00	46 - 12	8CC-85790-01	6 - 29	90105-07004	4 - 3	90110-06234	13 - 11
		8FN-77761-J0	34 - 7	8FP-82558-00	44 - 5	8ES-85885-01	10 - 45	90105-08072	19 - 8	90110-08N53	20 - 26

NUMERICAL INDEX

PART NO.	REF. NO.	PART NO.	REF. NO.	PART NO.	REF. NO.	PART NO.	REF. NO.	PART NO.	REF. NO.	PART NO.	REF. NO.
90111-05020	36 - 25	90183-08065	33 - 13	90201-121U3	21 - 41	90267-47195	19 - 13	90381-14001	21 - 37	90387-10029	20 - 14
90111-06042	25 - 35	90185-10110	28 - 34	90201-12317	32 - 7		19 - 45	90381-14101	28 - 31	90387-10031	27 - 5
90111-08054	25 - 44	90185-10115	29 - 8	90201-125A3	17 - 11		19 - 78		28 - 69		27 - 36
90113-05053	15 - 6	90201-047R8	28 - 6	90201-12790	6 - 30		19 - 86	90381-14109	28 - 73	90387-1009S	28 - 66
90113-06064	30 - 6	90201-05036	47 - 2	90201-141A3	16 - 24		36 - 9	90381-15001	19 - 3	90387-100X3	28 - 74
	31 - 66		47 - 5	90201-16245	31 - 72	90267-47200	19 - 70		19 - 6	90387-1012H	20 - 13
90119-06179	11 - 24		48 - 10	90201-205R6	27 - 30	90267-48010	36 - 4	90381-15N50	20 - 20	90387-1014Y	29 - 11
90119-08112	11 - 22	90201-05725	41 - 8	90201-207J5	28 - 44	90267-48014	26 - 5		20 - 30	90387-105G5	28 - 32
90119-09004	12 - 9	90201-06037	16 - 9	90201-210U0	28 - 14	90267-48016	19 - 14		20 - 56		28 - 79
90119-10004	1 - 11	90201-06042	32 - 15	90201-222F0	16 - 22		19 - 58		20 - 61	90387-105G6	28 - 20
90149-05129	6 - 82	90201-06050	25 - 42	90201-225A4	16 - 22		19 - 79	90381-16001	19 - 4	90387-10N58	20 - 33
90149-05299	35 - 7	90201-06072	33 - 42	90201-250T6	28 - 51	90267-48018	6 - 59		19 - 7	90387-10N59	20 - 52
90149-06148	6 - 37	90201-06099	31 - 29	90201-252F1	25 - 6		19 - 46	90381-16N51	20 - 39	90387-12N54	20 - 42
90149-06263	38 - 2	90201-061H1	16 - 9	90201-25526	16 - 21		19 - 69		20 - 63	90387-1404R	28 - 70
90149-06330	23 - 21	90201-06747	28 - 27	90201-25527	25 - 5		33 - 19	90381-18N51	20 - 21	90387-1407L	16 - 23
90149-08034	16 - 20	90201-08020	21 - 8	90201-266L1	28 - 50	90267-48023	19 - 21		20 - 57	90387-1815A	29 - 9
90150-05040	49 - 8	90201-08053	23 - 29	90201-266P2	31 - 51		19 - 47	90381-19111	28 - 16	90387-20022	27 - 26
	49 - 10	90201-08060	32 - 21	90201-286K9	28 - 54	90267-48083	19 - 68	90381-22099	28 - 43	90387-20023	27 - 27
90150-06015	22 - 14	90201-08075	23 - 30	90201-30013	14 - 6	90267-48086	37 - 33	90381-25115	20 - 19	90387-2004V	28 - 45
90151-05048	32 - 18	90201-08326	22 - 7	90201-320S3	31 - 63	90267-48095	19 - 77		20 - 55	90387-2008G	31 - 62
90151-06010	28 - 3	90201-08403	25 - 45	90202-08204	15 - 24	90267-48176	19 - 18	90381-28108	28 - 53	90387-203H0	27 - 22
	29 - 5	90201-08649	29 - 18		51 - 15		19 - 35	90383-17001	21 - 34	90387-22005	31 - 49
90151-06024	2 - 23	90201-086P8	20 - 9	90202-09227	15 - 21	90267-48177	19 - 19	90384-16251	28 - 85	90387-25011	25 - 4
90154-06009	33 - 34	90201-08759	21 - 55		51 - 17		19 - 22	90384-16N51	20 - 24	90387-25018	31 - 65
	37 - 23	90201-08784	6 - 85		52 - 7		19 - 48	90384-19001	32 - 9	90387-2508C	31 - 12
	38 - 7		20 - 8	90202-16229	28 - 86	90267-48182	6 - 39	90384-38243	16 - 6	90387-2515E	28 - 55
90154-06062	16 - 4	90201-100L3	27 - 13	90202-16232	28 - 87	90267-48194	28 - 5		16 - 12	90387-26007	31 - 56
90159-05035	45 - 25		28 - 21	90202-22238	29 - 10	90267-48199	28 - 11	90384-41242	15 - 4	90387-30005	31 - 53
90159-06011	33 - 35	90201-100S0	27 - 4	90208-26002	31 - 55	90269-05055	6 - 60		52 - 2	90387-514Y2	30 - 3
90170-08358	31 - 26		27 - 35	90209-15N50	20 - 37	90269-06006	15 - 27	90386-08002	15 - 26	90401-10015	25 - 15
90170-10186	21 - 31	90201-100U1	28 - 68		20 - 46		49 - 2	90386-09001	15 - 23		25 - 30
	21 - 50		28 - 77	90210-06006	19 - 57	90269-06046	42 - 4	90386-25002	28 - 15	90430-06192	8 - 8
90176-10075	19 - 25	90201-10118	25 - 16		31 - 74	90269-09002	19 - 89	90387-0514T	15 - 5	90430-08119	1 - 9
90179-05523	35 - 8		25 - 31	90210-08017	31 - 14	90280-03045	2 - 12		51 - 5	90430-08204	18 - 6
90179-06520	37 - 6	90201-10136	28 - 59	90215-10003	2 - 30	90282-07002	25 - 2	90387-0514U	15 - 14	90430-10148	31 - 41
	37 - 28		28 - 81	90249-06002	32 - 13	90338-20004	11 - 29		51 - 11	90430-14043	31 - 90
90179-08011	37 - 30	90201-101U2	28 - 94	90261-06015	49 - 2	90338-20007	11 - 30		52 - 3	90445-112E0	6 - 34
90179-08327	2 - 4	90201-103U4	28 - 67	90261-06019	49 - 2	90338-28242	37 - 24	90387-06033	43 - 4	90445-11M52	9 - 27
90179-08655	16 - 10	90201-10591	2 - 31	90261-06028	49 - 2	90338-30256	33 - 29	90387-06043	25 - 40	90445-120J6	6 - 50
90179-10679	31 - 35	90201-106F2	20 - 36	90261-06033	15 - 28	90340-14117	13 - 4	90387-06058	25 - 34	90445-120J8	6 - 35
90179-12004	17 - 7		20 - 45		49 - 2	90340-27001	1 - 5	90387-06059	32 - 12	90450-28014	6 - 49
90183-05024	42 - 8		20 - 53	90261-06034	49 - 2		12 - 2	90387-065V0	9 - 35	90450-35001	6 - 14
90183-05068	33 - 12		28 - 88	90266-06001	49 - 2	90340-32080	13 - 2	90387-06681	33 - 23		6 - 41
	36 - 15	90201-10742	21 - 45	90266-06002	49 - 2	90380-16109	29 - 13	90387-08071	11 - 21		6 - 69
90183-06053	33 - 32	90201-12032	20 - 47	90267-47186	24 - 15	90380-22232	28 - 91	90387-081M9	25 - 43		6 - 77
90183-060A0	11 - 11	90201-120T5	17 - 10		36 - 33	90380-28235	28 - 92	90387-082J1	29 - 16	90450-38040	6 - 7
	11 - 28	90201-12161	25 - 37		48 - 11	90380-28237	15 - 18	90387-083G6	28 - 62	90450-57016	9 - 3
90183-06100	33 - 33	90201-121H0	2 - 14	90267-47195	11 - 8		52 - 6	90387-10008	21 - 44	90450-67001	9 - 25

NUMERICAL INDEX

PART NO.	REF. NO.	PART NO.	REF. NO.	PART NO.	REF. NO.	PART NO.	REF. NO.	PART NO.	REF. NO.	PART NO.	REF. NO.
90460-15126	6 - 64	90467-17089	6 - 20	90501-603L3	49 - 4	93210-24235	40 - 10	95022-06020	4 - 7	95702-05300	47 - 6
	6 - 79		6 - 22	90501-624L8	49 - 4	93210-24709	12 - 4		6 - 28	95702-05500	47 - 8
90462-08225	13 - 8		6 - 23	90508-500B1	49 - 6	93210-25071	31 - 11	95022-06085	9 - 36	95702-06500	6 - 81
90462-10022	22 - 11	90467-20085	18 - 19	90508-536A9	49 - 6	93210-25642	16 - 19	95022-08012	1 - 8		9 - 34
90464-08126	46 - 11	90467-22080	18 - 20	90508-556A2	49 - 6	93210-26006	6 - 15	95022-08020	11 - 6		24 - 7
90464-09015	23 - 25	90467-22097	7 - 11	90508-556A7	49 - 6	93210-32172	13 - 3	95302-06700	40 - 7		37 - 19
90464-11007	22 - 2		7 - 12	90508-60007	49 - 6	93210-41041	23 - 10		40 - 11		43 - 5
90464-12045	45 - 15		7 - 14	90508-60012	16 - 13	93304-20511	31 - 3	95307-08700	31 - 27	95702-08300	23 - 28
90464-13073	26 - 3	90467-28046	6 - 66		49 - 6	93306-00006	5 - 5	95307-10600	31 - 10		45 - 22
	45 - 14	90467-28144	6 - 63	91312-06016	6 - 16		5 - 18	95307-10700	21 - 30	95702-08500	6 - 84
90464-13077	45 - 16		6 - 70		7 - 17	93306-00208	31 - 20		21 - 49		37 - 10
90464-13194	9 - 9	90467-310A0	6 - 67	91312-06020	9 - 2	93306-00444	27 - 16	95312-08600	21 - 23		37 - 12
90464-15195	6 - 78	90468-04092	23 - 5	91312-06025	5 - 16	93306-00711	31 - 38	95602-06200	33 - 24	95702-10300	21 - 52
	45 - 13	90468-08104	18 - 9	91312-06030	11 - 5	93306-20212	32 - 2		33 - 41	95702-10500	21 - 53
90464-16010	23 - 26		18 - 15	91312-06040	5 - 15	93306-20511	31 - 33	95602-08200	18 - 12	95707-05300	25 - 27
90464-20181	6 - 55	90468-12006	21 - 17	91312-06065	1 - 20	93306-20589	30 - 5		19 - 53	95707-05500	45 - 26
90464-25004	43 - 7	90480-16278	19 - 91	91316-06022	25 - 29	93306-20601	31 - 2		21 - 16	95707-06300	28 - 28
90464-35132	45 - 17	90480-18007	43 - 3	91317-06016	18 - 4	93306-30323	2 - 20		22 - 10	95707-08300	20 - 10
90465-06M28	6 - 31	90501-060A1	31 - 69	91401-20020	20 - 15	93306-30579	16 - 16	95602-10200	21 - 14	95707-08500	28 - 24
90465-08368	19 - 32	90501-066J5	31 - 78	91402-20020	21 - 54	93310-42239	2 - 24	95604-10200	27 - 6	95707-10300	27 - 29
90465-10038	13 - 9	90501-08668	23 - 17	91609-30008	29 - 12	93311-32685	31 - 48		27 - 37	95707-12300	29 - 23
90465-10048	6 - 38	90501-10353	31 - 88	91609-50032	15 - 12	93317-21578	31 - 68	95607-05200	15 - 8	9570M-08300	20 - 10
90465-13152	48 - 8	90501-120A0	25 - 36		51 - 16		31 - 71		15 - 16	95712-08300	37 - 36
90467-08092	9 - 11	90501-130A0	32 - 11	91808-16023	1 - 6		31 - 82		51 - 7	95802-06014	37 - 18
	9 - 13	90501-407E4	29 - 20	91808-22019	7 - 9		31 - 84		52 - 5	95802-06016	33 - 22
90467-09026	9 - 14	90501-550A2	49 - 4	91A20-05130	23 - 18	93317-33179	31 - 59	95607-06200	32 - 16	95807-08012	18 - 5
	23 - 19	90501-550A3	15 - 29	92012-06012	19 - 81	93317-41785	21 - 36	95607-08200	19 - 9	95812-06008	11 - 10
	23 - 27	90501-551L3	49 - 4	92012-08025	11 - 14	93410-06053	32 - 14		20 - 27		11 - 25
90467-10041	9 - 28	90501-551L9	49 - 4	92017-06014	25 - 41	93420-26077	5 - 19		27 - 8		11 - 27
90467-100A1	1 - 22	90501-552L5	49 - 4	92902-08600	37 - 37	93440-09141	1 - 4		27 - 39	95812-06012	7 - 20
	13 - 13	90501-580A1	49 - 4	92907-06600	15 - 20	93440-39175	31 - 79		28 - 60		32 - 24
90467-11019	13 - 14	90501-581L5	49 - 4		51 - 14	93450-19095	2 - 9		29 - 15	95812-06014	6 - 10
90467-11028	9 - 5	90501-581L6	49 - 4	92907-10600	27 - 32		2 - 11	95607-10100	28 - 35	95812-06016	6 - 54
	9 - 7	90501-582L1	49 - 4	92907-16100	15 - 32	93450-32152	2 - 27		28 - 71		11 - 12
	9 - 8	90501-582L2	49 - 4		51 - 19	93503-08007	31 - 87	95607-10200	19 - 11		18 - 11
90467-11032	6 - 36	90501-582L6	49 - 4	92990-08200	11 - 15	93604-16092	5 - 10		20 - 12		19 - 56
	6 - 51	90501-582L7	49 - 4	93102-10207	5 - 6	93606-20044	31 - 37		20 - 32	95812-06020	2 - 17
	23 - 7	90501-583L0	49 - 4	93102-15212	31 - 21	93700-06004	20 - 22		20 - 35	95812-06040	7 - 8
	23 - 16	90501-583L1	49 - 4	93102-30012	31 - 4		20 - 58		20 - 44	95812-06055	12 - 13
	23 - 24	90501-583L4	49 - 4	93102-35010	31 - 5		28 - 90		20 - 51	95812-06080	12 - 14
90467-110A2	6 - 3	90501-583L5	49 - 4		31 - 34	94580-25064	7 - 18		28 - 95	95812-08014	36 - 30
	6 - 5	90501-600A1	49 - 4	93210-06001	40 - 4	94591-59140	4 - 4		31 - 44		36 - 34
	6 - 8	90501-601L7	49 - 4	93210-14369	13 - 5	94701-00411	1 - 10	95607-12200	20 - 41	95812-08016	37 - 13
	6 - 12	90501-601L8	49 - 4	93210-14579	7 - 7	94703-00411	1 - 10		32 - 4	95812-08020	11 - 18
	6 - 13	90501-602L3	49 - 4	93210-16629	7 - 16	94890-09068	31 - 57	95607-14200	27 - 23	95812-08030	17 - 3
	6 - 18	90501-602L8	49 - 4	93210-18322	7 - 6		50 - 2		27 - 31		40 - 13
90467-12053	18 - 10	90501-602L9	49 - 4	93210-19026	18 - 3	94890-09070	50 - 2	95617-08630	16 - 7	95812-08055	12 - 10
	18 - 17	90501-603L2	49 - 4	93210-19123	1 - 16	95022-06008	46 - 9	95702-05300	47 - 3	95812-08070	12 - 11

NUMERICAL INDEX

PART NO.	REF. NO.	PART NO.	REF. NO.	PART NO.	REF. NO.	PART NO.	REF. NO.	PART NO.	REF. NO.	PART NO.	REF. NO.
95817-08035	29 - 14	9702M-08055	20 - 6								
95817-10030	29 - 7	9702M-08100	20 - 7								
95817-10080	27 - 3	97702-50016	33 - 17								
	27 - 34		35 - 3								
95817-12100	17 - 5		41 - 7								
95817-12200	17 - 6	97702-50020	19 - 84								
95822-06010	45 - 4		35 - 4								
95822-06012	6 - 53	98502-04014	10 - 23								
	6 - 80	98502-05016	44 - 8								
	19 - 72	98502-06016	5 - 8								
95822-06016	9 - 38	98706-04012	25 - 22								
	45 - 3	98902-05008	23 - 11								
	48 - 6	98902-06016	37 - 27								
95822-06020	18 - 21	98902-08020	37 - 29								
	37 - 5	99001-04600	44 - 4								
95822-08014	24 - 20	99002-08600	5 - 11								
95822-08016	6 - 83	99009-20400	28 - 46								
	19 - 75	99009-24400	25 - 3								
	37 - 9	99009-25400	16 - 18								
	37 - 16		27 - 12								
	46 - 4	99009-26400	31 - 50								
95822-08020	19 - 76	99009-35500	32 - 3								
	22 - 8	99009-42500	27 - 17								
	37 - 2	99009-52500	31 - 7								
95822-08025	37 - 35		31 - 36								
	37 - 39	99009-62500	16 - 17								
	37 - 41		31 - 6								
95822-10016	19 - 54	99246-00200	34 - 11								
95822-10020	37 - 8	99530-08012	5 - 14								
	37 - 17		8 - 3								
95827-06025	31 - 46		13 - 7								
95827-08014	32 - 20	99530-10014	12 - 7								
95827-08016	32 - 6	99530-10114	12 - 8								
95827-08020	32 - 22										
95827-08030	31 - 42										
95827-08220	28 - 61										
95827-10025	30 - 9										
95827-10045	31 - 43										
95827-10090	31 - 45										
95880-06025	45 - 7										
97007-06025	28 - 26										
97007-08014	31 - 13										
97012-10025	2 - 29										
97017-06030	15 - 19										
	51 - 13										
97027-08055	20 - 6										
97027-08100	20 - 7										
97027-10025	28 - 89										