

PARTS CATALOGUE

VK10B (8GSC) CANADA

VK10B (8GSD) EUROPE, RUS, JAPAN

1L8GS-100E1

()



2016/03/23

NEWS No.	DATE	COMMENT
PE0-SM-110011	Sep.,13,2011	COR: PRIMARY SHEAVE, ALTERNATE REBUILD KIT ILLUSTRATION CORRECTION
PE0-SM-120001	Jan.,25,2012	COR:FIG.10 CARBURETOR ILLUSTRATION CORRECTION
PE0-SM-130007	Jul.,31,2013	MOD:FIG.31 TRACI DRIVE 2 LIST ILLUSTRATION CORRECTION
PE0-SM-130008	Sep.,10,2013	COR:FIG.28 TRACK SUSPENSION 2 ILLUSTRATION CORRECTION
PE0-SM-160011	Mar.,11,2016	COR:FIG.16 SECONDARY SHEAVE/31 TRACK DRIVE 2 LIST&ILLUST CORRECTION

VK10B
PARTS CATALOGUE
©2011 by Yamaha Motor Co., Ltd.
1st edition, May 2011
All rights reserved.
Any reprinting or unauthorized use
without the written permission of
Yamaha Motor Co., Ltd.
is expressly prohibited.
Printed in Japan.

FOREWORD

This Parts Catalogue is related to the parts for the model(s) on the cover page. When you are ordering replacement parts, please refer to this Parts Catalogue and quote both part numbers and part names correctly.

1. Modifications or additions which have been made after the issue of the Parts Catalogue will be announced in the Parts News.

It is advisable that you make the necessary corrections to the Parts Catalogue according to the Parts News.

2. Abbreviations

The following abbreviations are used in this Parts Catalogue.

“UR” Use specified parts number.

“UN” Use as many as needed.

“AP” Alternate Parts

“LM” Locally Made (Parts need to be ordered locally)

“F#” Frame No. (Applicable machine No.)

“O/S” Over Size

3. The number of components for assembly

- Parts, which are to be supplied in an assembly, are listed with a dot (.) in front of the part name as shown below.
- The numeral appearing to the right of each component part indicates the quantity of parts for each assembly unit.

PART NO.	DESCRIPTION	Q'TY	REMARKS
2F5-83310-60	FRONT FLASHER LIGHT ASSY	2	
115-83311-60	.BULB (6V-18W)	1	

4. Applicable colours of graphics are represented in the “REMARKS” as shown below.

PART NO.	DESCRIPTION	Q'TY	REMARKS
2N4-24110-00-X5	FUEL TANK COMP.	2	MXR
3J1-24240-10	.GRAPHIC, FUEL TANK	1	FOR MXR

5. Note that the illustrations for reference in finding parts numbers are not to be used for assembling. When assembling, please use the applicable service manual.

6. The asterisk (*) before a reference number indicates modified items after the first edition.

FOREWORD

7. Applicable Serial No.

Engine Serial No.

Frame Serial No.

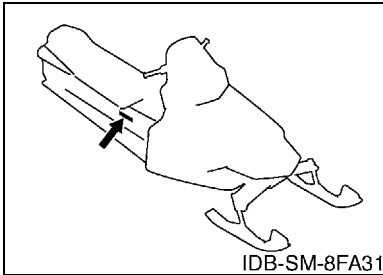
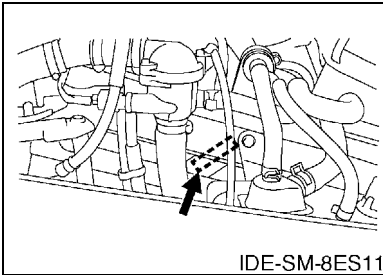

10. Applicable Starting Serial No.

Frame Serial No.

Serial No.	Name Of Q'ty Column	Model Code
JYE8GS001CA018218	8GSC	8GSC
JYE8GS001CA018218	8GSD	8GSD

8. Applicable Colour Code (The (*) mark shows Model colour.)

Abbreviation	Colour Name	Colour Code
DRMK(*)	DEEP RED METALLIC K	0918

9. Quantity Column Information

Column No.	Name Of Q'ty Column	Destination
1	8GSC	CANADA
2	8GSD	EUROPE, RUS, JAPAN

CONTENTS

ENGINE

CYLINDER HEAD	1
CRANKSHAFT & PISTON	2
VALVE	4
CAMSHAFT & CHAIN	6
WATER PUMP	7
RADIATOR & HOSE	8
OIL PUMP	12
OIL CLEANER	13
INTAKE	14
CARBURETOR	16
EXHAUST	19
CRANKCASE	21
CRANKCASE COVER 1	22
STARTER	23

DRIVE

PRIMARY SHEAVE	24
SECONDARY SHEAVE	26

BODY

ENGINE BRACKET	27
OIL TANK	28
FRAME	29
SKI	33
STEERING	36
STEERING GATE	39
FUEL TANK	40
SEAT	42
BRAKE	43
CONTROL CABLE	45
TRACK SUSPENSION 1	46
TRACK SUSPENSION 2	48
TRACK SUSPENSION 3	52
TRACK DRIVE 1	53
TRACK DRIVE 2	54
TRACK DRIVE 3	58
SHROUD	59
EMBLEM	61
WINDSHIELD	62
GUARD & LUGGAGE BOX	63
BUMPER	65

INSTRUMENT PANEL	67
------------------------	----

ELECTRICAL

GENERATOR	68
STARTING MOTOR	69
METER	70
HEADLIGHT	71
TAILLIGHT	72
HANDLE SWITCH & LEVER	73
ELECTRICAL 1	74
ELECTRICAL 2	75
ELECTRICAL 3	76
ELECTRICAL 4	77
ALTERNATE DRIVE SETTING 1	78
ALTERNATE DRIVE SETTING 2	81
ALTERNATE REBUILD KIT	82
ALTERNATE CLUTCH TUNE UP KIT	83

INDEX

NUMERICAL INDEX	84
-----------------------	----

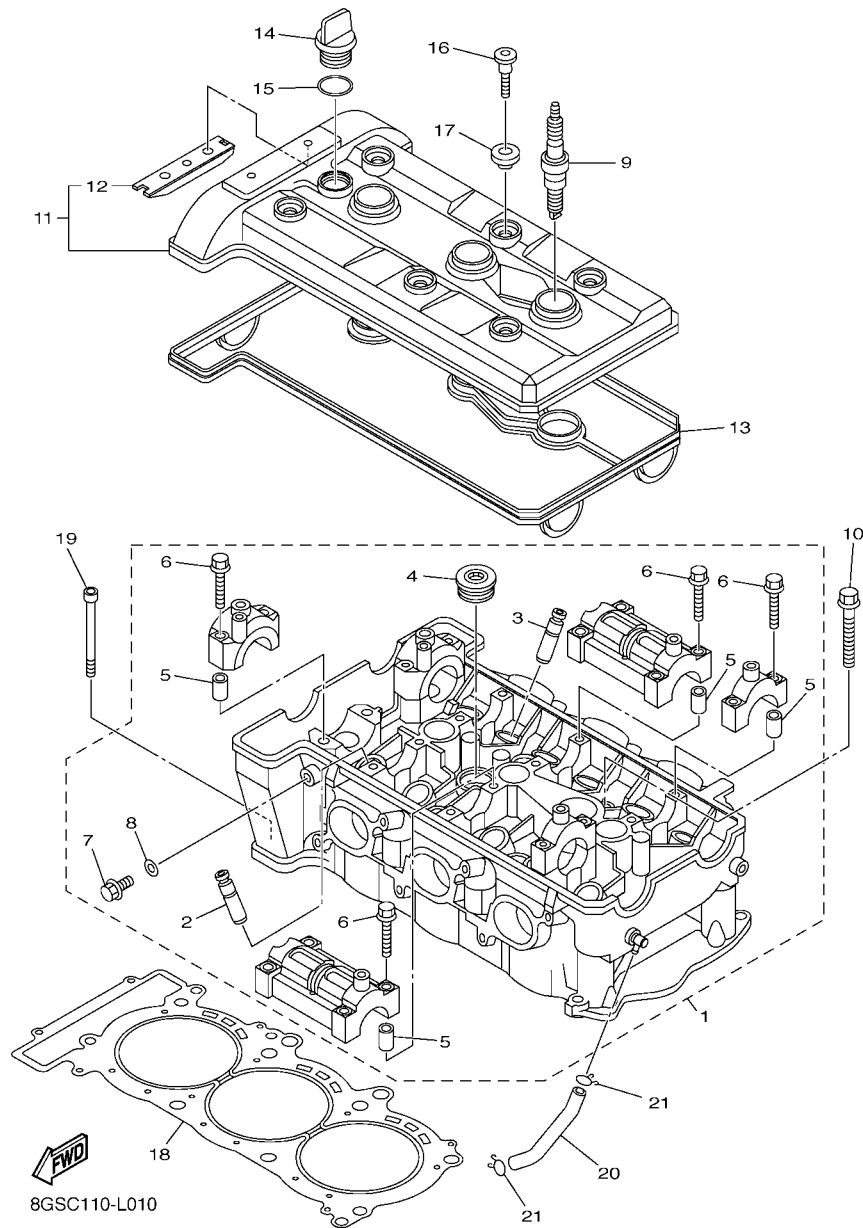
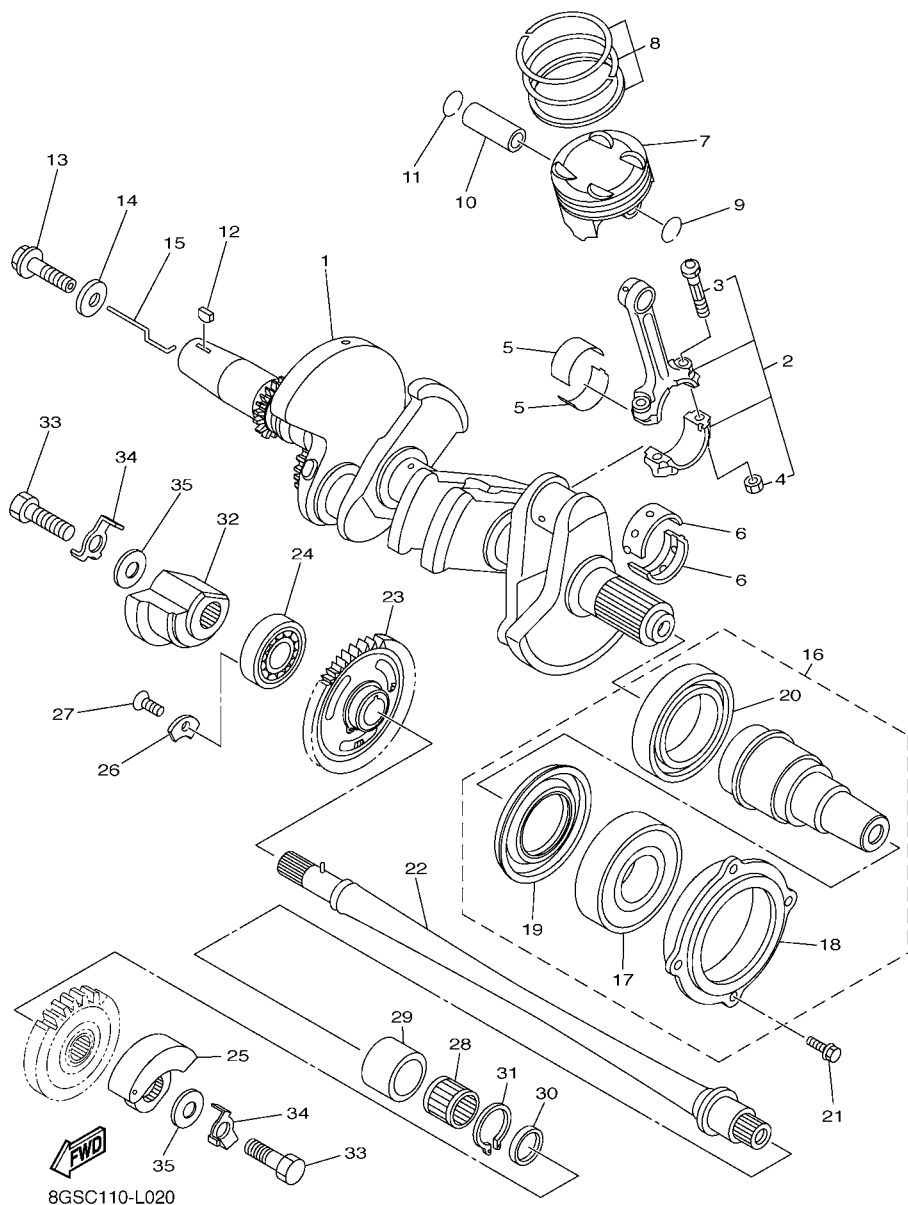

FIG. 1 CYLINDER HEAD

REF. NO.	PART NO.	DESCRIPTION	8GSC	8GSD	REMARKS
1	8ES-11101-02	CYLINDER HEAD ASSY	1	1	
2	5JW-11133-10	.GUIDE, VALVE 1	6	6	
3	3P6-11134-10	.GUIDE, VALVE 2	6	6	
4	90340-27129	.PLUG, STRAIGHT SCREW	1	1	
5	91808-16023	.PIN, DOWEL	12	12	
6	90105-06026	.BOLT, FLANGE	16	16	
7	95022-08012	.BOLT, FLANGE	1	1	
8	90430-08119	.GASKET	1	1	
9	94701-00411	PLUG, SPARK (NGK R CR8E)	3	3	UR FOR EUR,RUS
	94703-00411	PLUG, SPARK (NGK R CR8E)	3	3	UR FOR JPN
10	90119-10004	BOLT, WITH WASHER	8	8	
11	8ES-11191-01	COVER, CYLINDER HEAD 1	1	1	
12	5BE-12241-00	.GUIDE, STOPPER 2	1	1	
13	8ES-11193-00	GASKET, HEAD COVER 1	1	1	
14	3Y1-15363-10	PLUG, OIL	1	1	
15	93210-19123	O-RING	1	1	
16	90109-066F0	BOLT	6	6	
17	4KG-1111G-00	RUBBER, MOUNT 1	6	6	
18	8ES-11181-00	GASKET, CYLINDER HEAD 1	1	1	
19	91312-06065	BOLT	2	2	
20	8ES-13416-00	PIPE, OIL 1	1	1	
21	90467-100A1	CLIP	2	2	

FIG. 2 CRANKSHAFT & PISTON

REF. NO.	PART NO.	DESCRIPTION	8GSC	8GSD		REMARKS
1	8ES-11400-02	CRANKSHAFT ASSY	1	1		
2	5JW-11650-01	CONNECTING ROD ASSY	3	3		
3	5JW-11654-00	.BOLT, CONNECTING ROD	2	2		
4	90179-08327	.NUT	2	2		
5	5JW-11656-A0	PLANE BEARING, CONNECTING ROD	6	6		UR WHITE
5JW-11656-00	PLANE BEARING, CONNECTING ROD	6	6		UR BLUE	
5JW-11656-10	PLANE BEARING, CONNECTING ROD	6	6		UR BLACK	
5JW-11656-20	PLANE BEARING, CONNECTING ROD	6	6		UR BROWN	
5JW-11656-30	PLANE BEARING, CONNECTING ROD	6	6		UR GREEN	
5JW-11656-40	PLANE BEARING, CONNECTING ROD	6	6		UR YELLOW	
6	3LD-11416-10	PLANE BEARING, CRANKSHAFT 1	8	8		UR BLACK
3LD-11416-20	PLANE BEARING, CRANKSHAFT 1	8	8		UR BROWN	
3LD-11416-30	PLANE BEARING, CRANKSHAFT 1	8	8		UR GREEN	
3LD-11416-40	PLANE BEARING, CRANKSHAFT 1	8	8		UR YELLOW	
3LD-11416-50	PLANE BEARING, CRANKSHAFT 1	8	8		UR PINK	
3LD-11416-60	PLANE BEARING, CRANKSHAFT 1	8	8		UR RED	
3LD-11416-70	PLANE BEARING, CRANKSHAFT 1	8	8		UR WHITE	
7	8ES-11631-00	PISTON (STD)	3	3		
8	5JW-11603-00	PISTON RING SET (STD)	3	3		
9	93450-19095	CIRCLIP	3	3		
10	5JW-11633-00	PIN, PISTON	3	3		
11	93450-19095	CIRCLIP	3	3		
12	90280-03045	KEY, WOODRUFF	1	1		
13	90105-12032	BOLT, FLANGE	1	1		
14	90201-121H0	WASHER, PLATE	1	1		
15	59J-11455-00	SHAFT 1	1	1		
16	8ES-11406-02	SHAFT ASSY	1	1		



8GSC110-L020

FIG. 2 CRANKSHAFT & PISTON

REF. NO.	PART NO.	DESCRIPTION	8GSC	8GSD	REMARKS
17	93306-30721	.BEARING	1	1	
18	8ES-16775-00	.HOUSING, BEARING	1	1	
19	93102-45008	.OIL SEAL	1	1	
20	93306-01003	.BEARING	1	1	
21	95812-06020	BOLT, FLANGE	4	4	
22	8ES-11407-02	SHAFT ASSY., 2	1	1	
23	8ES-11530-00	BALANCER WEIGHT GEAR COMP.	1	1	
24	93306-30323	BEARING	1	1	
25	8ES-11454-00	WEIGHT 1	1	1	
26	4JT-15381-01	PLATE, BEARING COVER	1	1	
27	90151-06024	SCREW, COUNTERSUNK	1	1	
28	93310-42239	BEARING	1	1	
29	8ES-11428-01	BEARING 1	1	1	
30	8ES-11478-00	COLLAR	1	1	
31	93450-32152	CIRCLIP	1	1	
32	8ES-11464-00	WEIGHT 2	1	1	
33	97012-10025	BOLT	2	2	
34	90215-10003	WASHER, LOCK	2	2	
35	90201-10591	WASHER, PLATE	2	2	

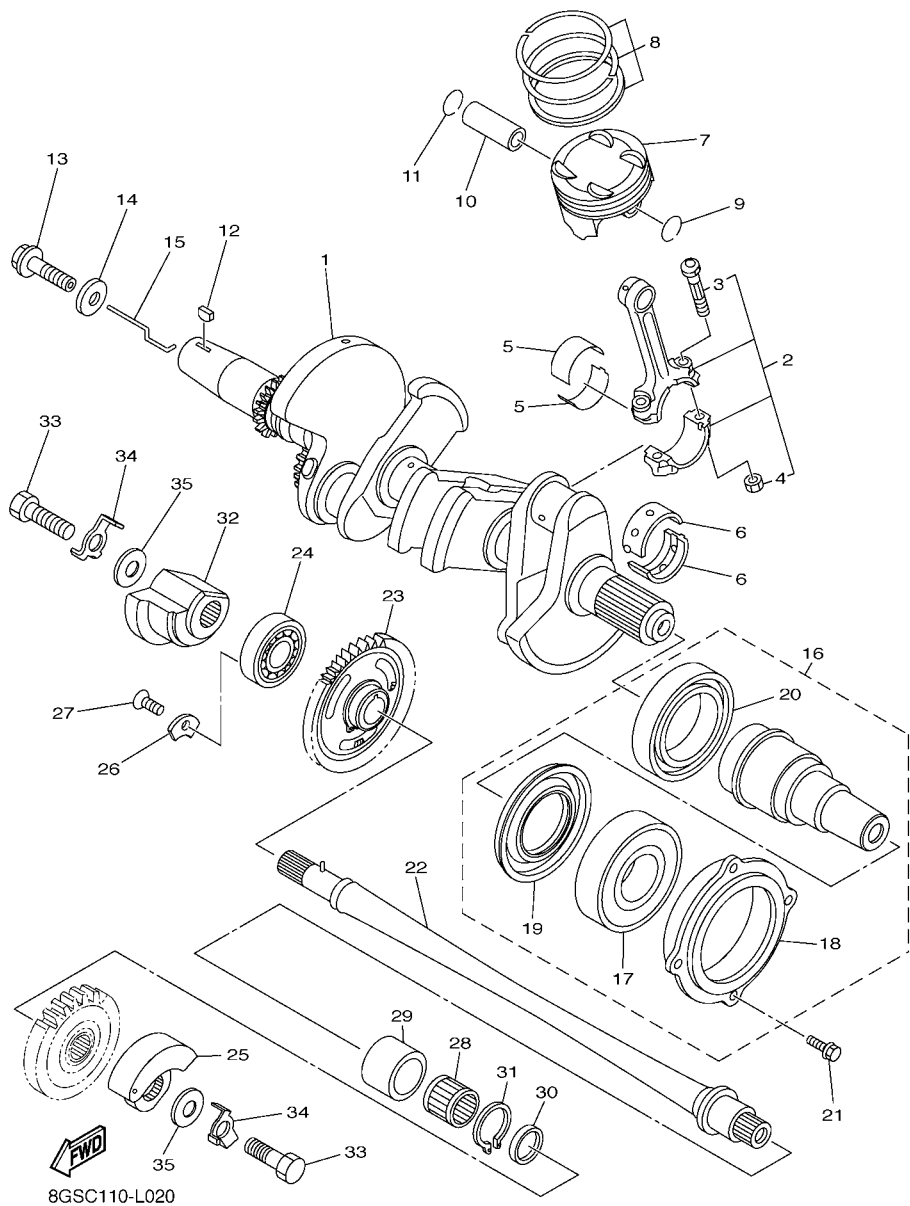

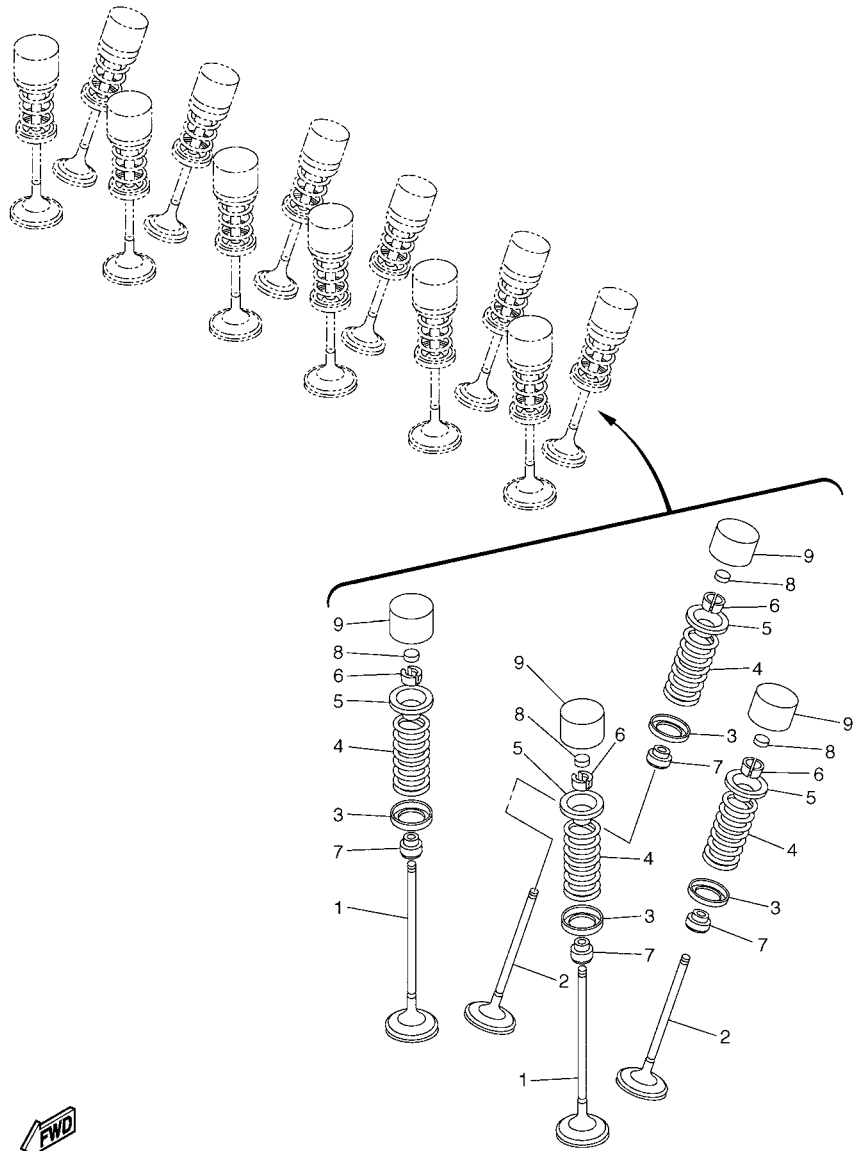

8ES1100-D030

FIG. 3 VALVE

REF. NO.	PART NO.	DESCRIPTION	8GSC	8GSD		REMARKS
1	5JW-12111-00	VALVE, INTAKE	6	6		
2	5JW-12121-01	VALVE, EXHAUST	6	6		
3	5JW-12116-00	SEAT, VALVE SPRING	12	12		
4	5JW-12113-00	SPRING, VALVE INNER	12	12		
5	5JW-12117-00	RETAINER, VALVE SPRING	12	12		
6	1AA-12118-00	COTTER, VALVE	24	24		
7	3P6-12129-00	SEAL, VALVE STEM	12	12		
8	3LD-12168-00	PAD, ADJUSTING (1.20)	12	12		UR
	3LD-12168-20	PAD, ADJUSTING (1.25)	12	12		UR
	3LD-12168-40	PAD, ADJUSTING (1.30)	12	12		UR
	3LD-12168-60	PAD, ADJUSTING (1.35)	12	12		UR
	3LD-12168-80	PAD, ADJUSTING (1.40)	12	12		UR
	3LD-12168-A0	PAD, ADJUSTING (1.45)	12	12		UR
	3LD-12168-F0	PAD, ADJUSTING (1.50)	12	12		UR
	3LD-12168-H1	PAD, ADJUSTING (1.55)	12	12		UR
	3LD-12168-K1	PAD, ADJUSTING (1.60)	12	12		UR
	3LD-12168-M1	PAD, ADJUSTING (1.65)	12	12		UR
	3LD-12168-R1	PAD, ADJUSTING (1.70)	12	12		UR
	3LD-12168-U1	PAD, ADJUSTING (1.75)	12	12		UR
	3LD-12168-W1	PAD, ADJUSTING (1.80)	12	12		UR
	3LD-12168-Y1	PAD, ADJUSTING (1.85)	12	12		UR
	3LD-12169-11	PAD, ADJUSTING (1.90)	12	12		UR
	3LD-12169-31	PAD, ADJUSTING (1.95)	12	12		UR
	3LD-12169-50	PAD, ADJUSTING (2.00)	12	12		UR
	3LD-12169-70	PAD, ADJUSTING (2.05)	12	12		UR
	3LD-12169-90	PAD, ADJUSTING (2.10)	12	12		UR
	3LD-12169-E0	PAD, ADJUSTING (2.15)	12	12		UR

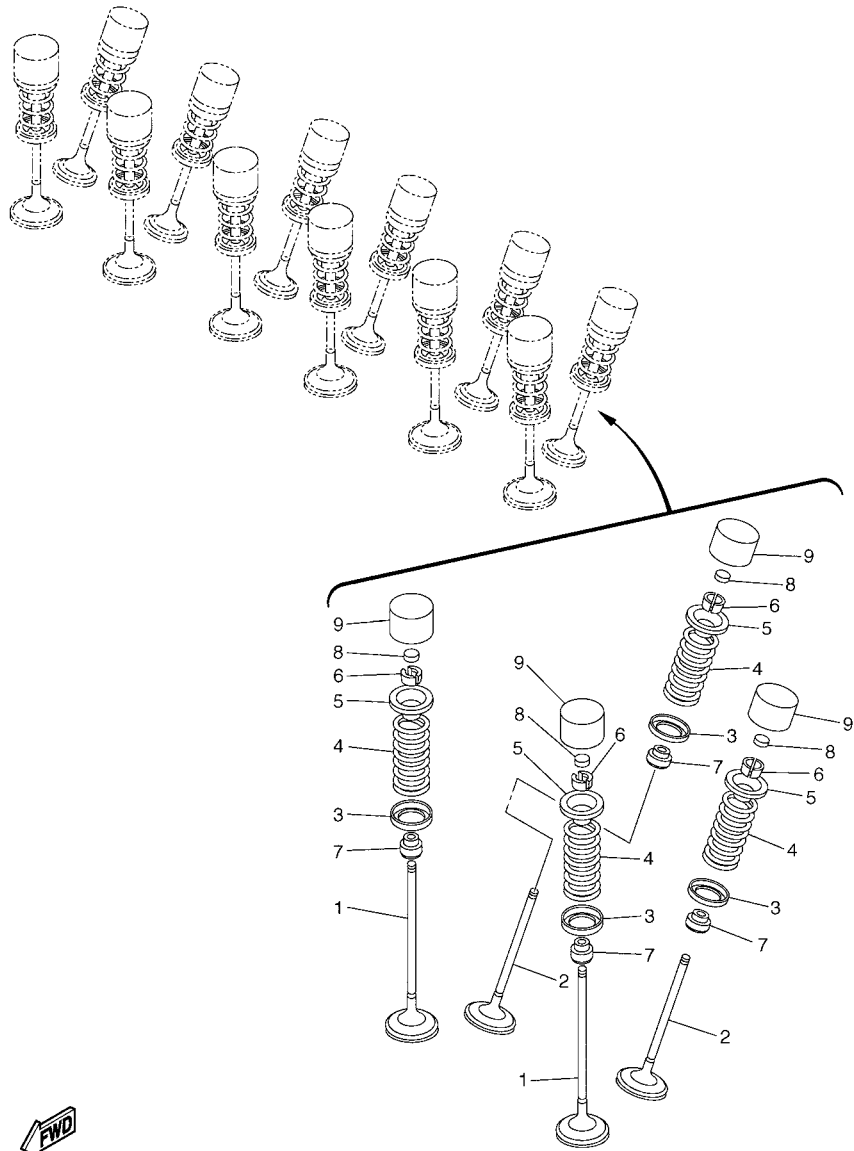

8ES1100-D030

FIG. 3 VALVE

REF. NO.	PART NO.	DESCRIPTION	8GSC	8GSD		REMARKS
8	3LD-12169-G0	PAD, ADJUSTING (2.20)	12	12		UR
	3LD-12169-J0	PAD, ADJUSTING (2.25)	12	12		UR
	3LD-12169-L0	PAD, ADJUSTING (2.30)	12	12		UR
	3LD-12169-N0	PAD, ADJUSTING (2.35)	12	12		UR
	3LD-12169-T0	PAD, ADJUSTING (2.40)	12	12		UR
9	5EB-12153-10	LIFTER, VALVE	12	12		UR YELLOW
	5EB-12153-09	LIFTER, VALVE (O/S)	12	12		UR GREEN

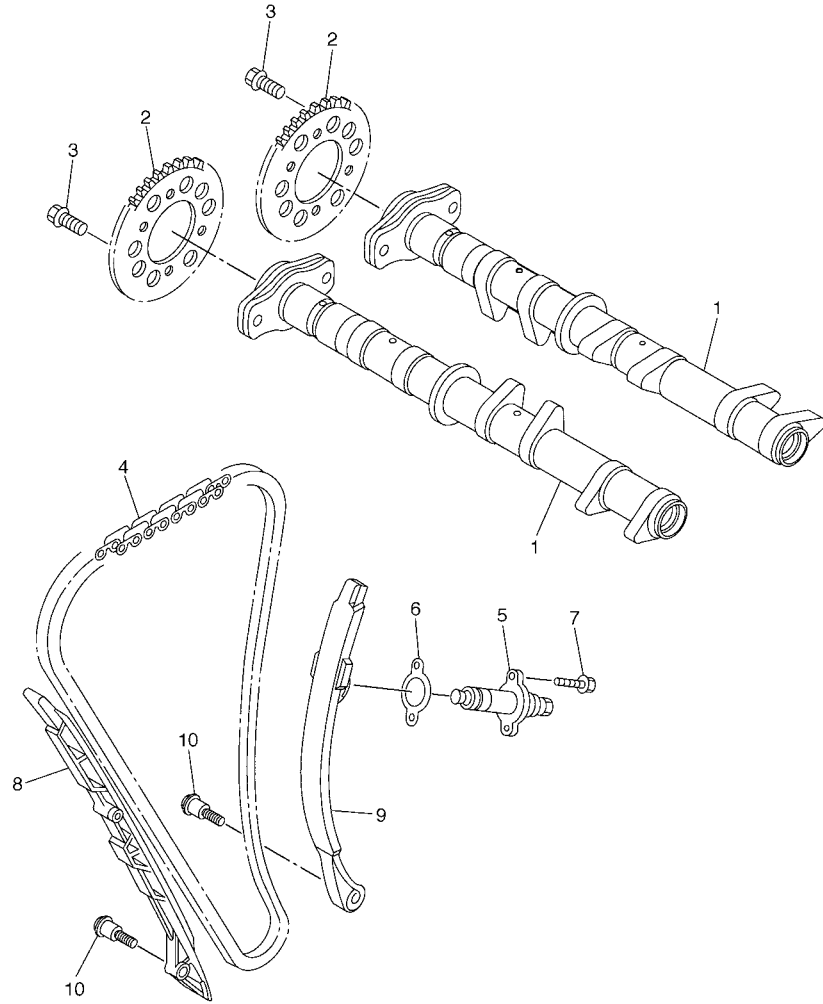

8ES1100-D040

FIG. 4 CAMSHAFT & CHAIN

REF. NO.	PART NO.	DESCRIPTION	8GSC	8GSD		REMARKS
1	8ES-12170-01	CAMSHAFT ASSY 1	2	2		
2	8ES-12176-00	SPROCKET, CAM CHAIN	2	2		
3	90105-07004	BOLT, FLANGE	4	4		
4	94591-59140	CHAIN	1	1		
5	8ES-12210-01	TENSIONER ASSY, CAM CHAIN	1	1		
6	4FM-12213-00	GASKET, TENSIONER CASE	1	1		
7	95022-06020	BOLT, FLANGE	2	2		
8	8ES-12251-00	DAMPER, CHAIN 1	1	1		
9	8ES-12252-00	DAMPER, CHAIN 2	1	1		
10	90109-06187	BOLT	2	2		

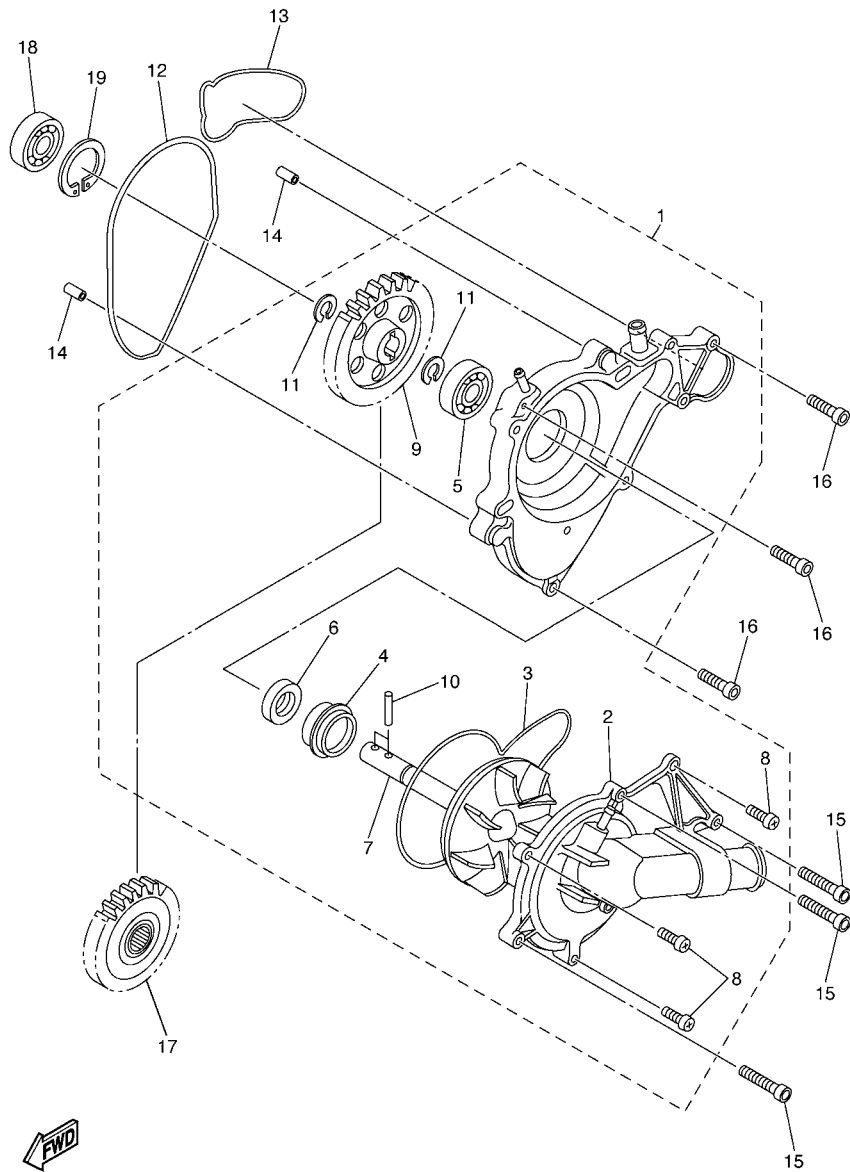

8FJ3100-E050

FIG. 5 WATER PUMP

REF. NO.	PART NO.	DESCRIPTION	8GSC	8GSD	REMARKS
1	8ES-12420-02	WATER PUMP ASSY	1	1	
2	8ES-12422-00	.COVER, HOUSING	1	1	
3	8ES-12427-00	.GASKET, HOUSING COVER 1	1	1	
4	8ES-12438-00	.SEAL, MECHANICAL	1	1	
5	93306-00006	.BEARING	1	1	
6	93102-10207	.OIL SEAL (SD 10-21-5 HS)	1	1	
7	8ES-12450-01	.IMPELLER SHAFT ASSY	1	1	
8	98502-06016	.SCREW, PAN HEAD	3	3	
9	8ES-12459-01	.GEAR, IMPELLER SHAFT	1	1	
10	93604-16092	.PIN, DOWEL	2	2	
11	99002-08600	.CLIP	2	2	
12	8ES-12435-00	GASKET	1	1	
13	8ES-12434-00	GASKET	1	1	
14	99530-08012	PIN, DOWEL	2	2	
15	91312-06040	BOLT	4	4	
16	91312-06025	BOLT	3	3	
17	8ES-12436-00	GEAR, DRIVE	1	1	
18	93306-00006	BEARING	1	1	
19	93420-26077	CIRCLIP	1	1	

FIG. 6 RADIATOR & HOSE

REF. NO.	PART NO.	DESCRIPTION	8GSC	8GSD	REMARKS
1	8ES-12482-00	PIPE 2	1	1	
2	8ES-12485-01	PIPE 5	1	1	
3	90467-110A2	CLIP	2	2	
4	8FN-12577-00	HOSE 2	1	1	
5	90467-110A2	CLIP	1	1	
6	8FN-1243E-00	HOSE 2	1	1	
7	90450-38040	HOSE CLAMP ASSY	1	1	
8	90467-110A2	CLIP	1	1	
9	8FW-1249A-00	COCK ASSY	1	1	
10	95812-06014	BOLT, FLANGE	2	2	
11	8FN-12579-00	HOSE 4	1	1	
12	90467-110A2	CLIP	1	1	
13	90467-110A2	CLIP	1	1	
14	90450-35001	HOSE CLAMP ASSY	1	1	
15	93210-26006	O-RING	1	1	
16	91312-06016	BOLT	1	1	
17	8ES-12578-00	HOSE 3	1	1	
18	90467-110A2	CLIP	2	2	
19	8ES-12588-00	HOSE 5	1	1	
20	90467-17089	CLIP	2	2	
21	8FN-12589-00	HOSE 6	1	1	
22	90467-17089	CLIP	1	1	
23	90467-17089	CLIP	1	1	
24	8FN-12580-00	JOINT ASSY	1	1	
25	5EB-12413-00	.COVER, THERMOSTAT	1	1	
26	8FN-12410-00	.THERMOSTAT ASSY	1	1	
27	8EK-12412-00	..SEAL, THERMOSTAT	1	1	

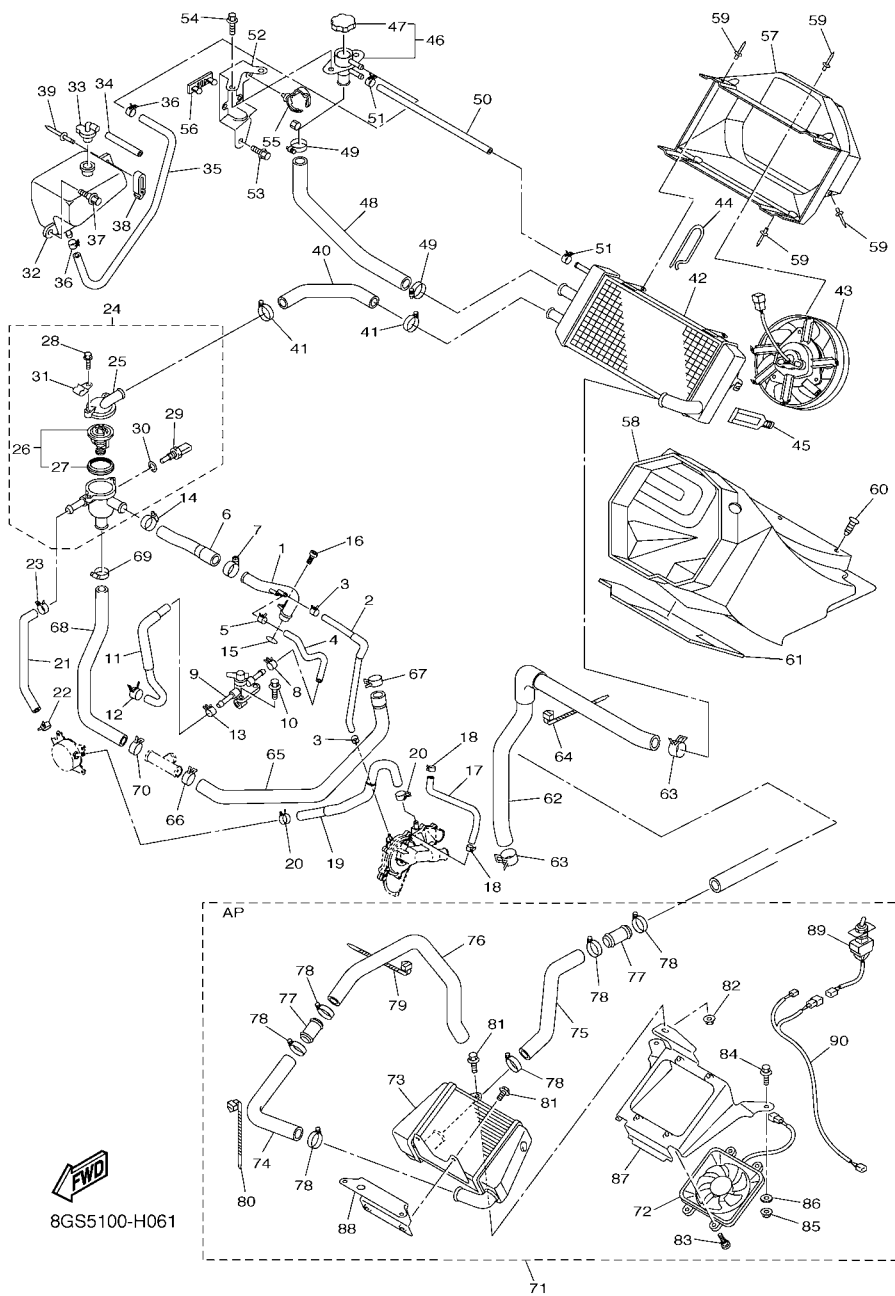
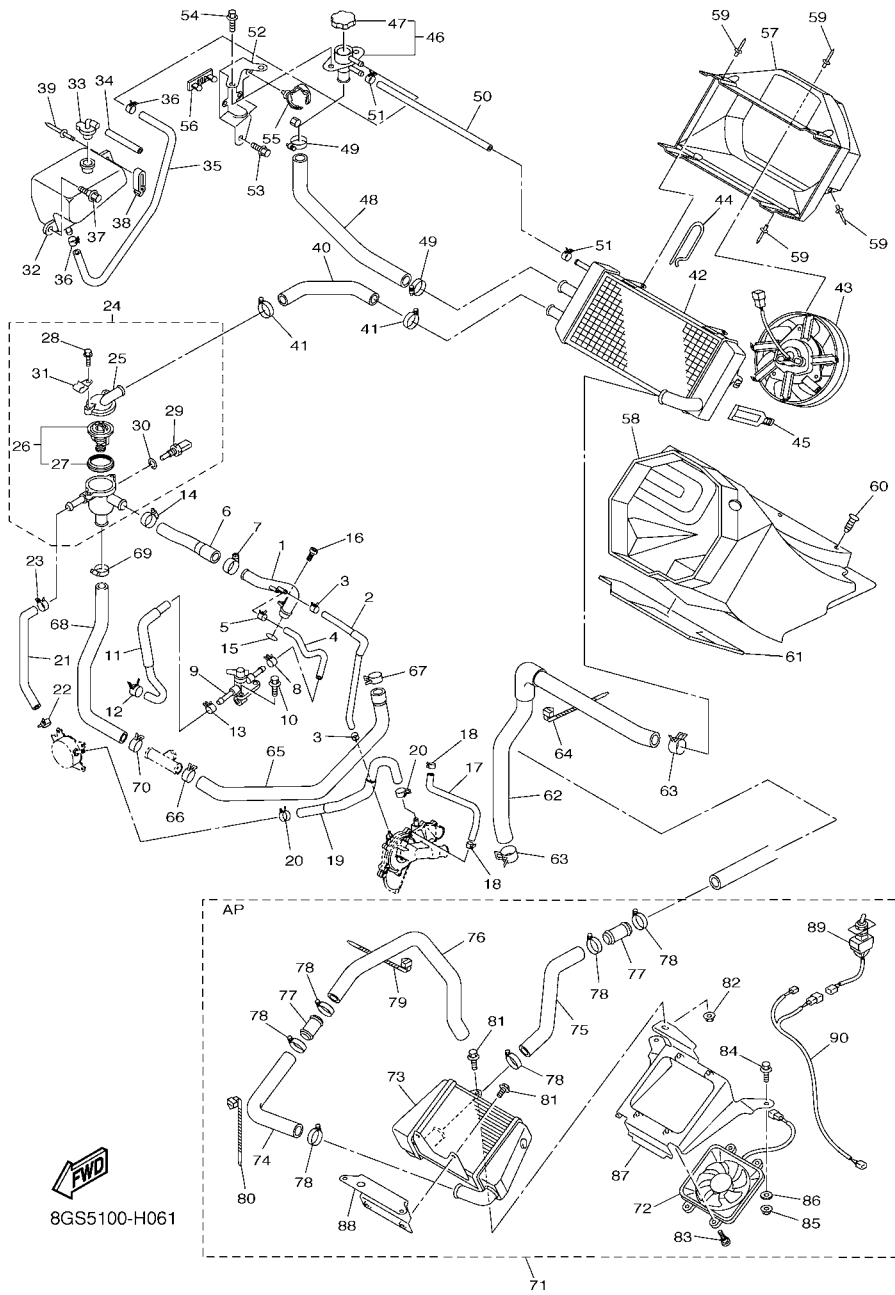

FIG. 6 RADIATOR & HOSE

REF. NO.	PART NO.	DESCRIPTION	8GSC	8GSD	REMARKS
28	95022-06020	.BOLT, FLANGE	2	2	
29	8CC-85790-01	.THERMOSENSOR ASSY	1	1	
30	90201-12790	.WASHER, PLATE	1	1	
31	90465-06M28	.CLAMP	1	1	
32	8FN-21871-00	TANK, RECOVERY	1	1	
33	89A-21815-00	CAP	1	1	
34	90445-112E0	HOSE (L70)	1	1	
35	90445-120J8	HOSE (L450)	1	1	
36	90467-11032	CLIP	2	2	
37	90149-06148	SCREW	2	2	
38	90465-10048	CLAMP	1	1	
39	90267-48182	RIVET, BLIND (4.8X23)	1	1	
40	8FN-1244G-00	HOSE, 4	1	1	
41	90450-35001	HOSE CLAMP ASSY	2	2	
42	8FN-12460-00	RADIATOR ASSY	1	1	
43	8FN-12405-01	BLOWER ASSY	1	1	
44	8CR-77384-01	PIN	1	1	
45	8FA-2389E-00	LATCH	1	1	
46	8FN-12590-00	CONDUCTION ASSY	1	1	
47	3XP-12462-00	.CAP, RADIATOR	1	1	
48	8FN-1244H-00	HOSE 5	1	1	
49	90450-28014	HOSE CLAMP ASSY	2	2	
50	90445-120J6	HOSE (L250)	1	1	
51	90467-11032	CLIP	2	2	
52	8FN-1244E-00	BRACKET 1	1	1	
53	95822-06012	BOLT, FLANGE	2	2	
54	95812-06016	BOLT, FLANGE	2	2	



8GS5100-H061

FIG. 6 RADIATOR & HOSE

REF. NO.	PART NO.	DESCRIPTION	8GSC	8GSD	REMARKS
55	90464-20181	CLAMP	1	1	
56	8FA-83614-00	BRACKET	1	1	
57	8FN-12467-00	COVER, RADIATOR	1	1	
58	8FN-21851-00	DUCT, COOLER	1	1	
59	90267-48018	RIVET, BLIND (4.8X18.6 BLACK)	7	7	
60	90269-05055	RIVET	6	6	
61	8FN-77261-00	LINING, SHROUD 1	1	1	
62	8FN-12477-02	PIPE 7	1	1	
63	90467-28144	CLIP	2	2	
64	90460-15126	CLAMP, HOSE	1	1	
65	8FN-1248A-00	PIPE 8	1	1	
66	90467-28046	CLIP	1	1	
67	90467-310A0	CLIP	1	1	
68	8FN-1248E-00	PIPE 9	1	1	
69	90450-35001	HOSE CLAMP ASSY	1	1	
70	90467-28144	CLIP	1	1	
71	8GS-W1246-00	VK10 SUB RADIATOR KIT	1	1	AP
72	8FP-12405-00	.BLOWER ASSY	1	1	AP
73	8GS-12461-00	.RADIATOR COMP	1	1	AP
74	8FN-1244J-00	.HOSE 6	1	1	AP
75	8FN-1243A-00	.HOSE 1	1	1	AP
76	8FN-1243F-00	.HOSE,3	1	1	AP
77	8FN-12469-00	.JOINT 1	2	2	AP
78	90450-35001	.HOSE CLAMP ASSY	6	6	AP
79	90464-15195	.CLAMP	1	1	AP
80	90460-15126	.CLAMP, HOSE	1	1	AP
81	95822-06012	.BOLT, FLANGE	3	3	AP

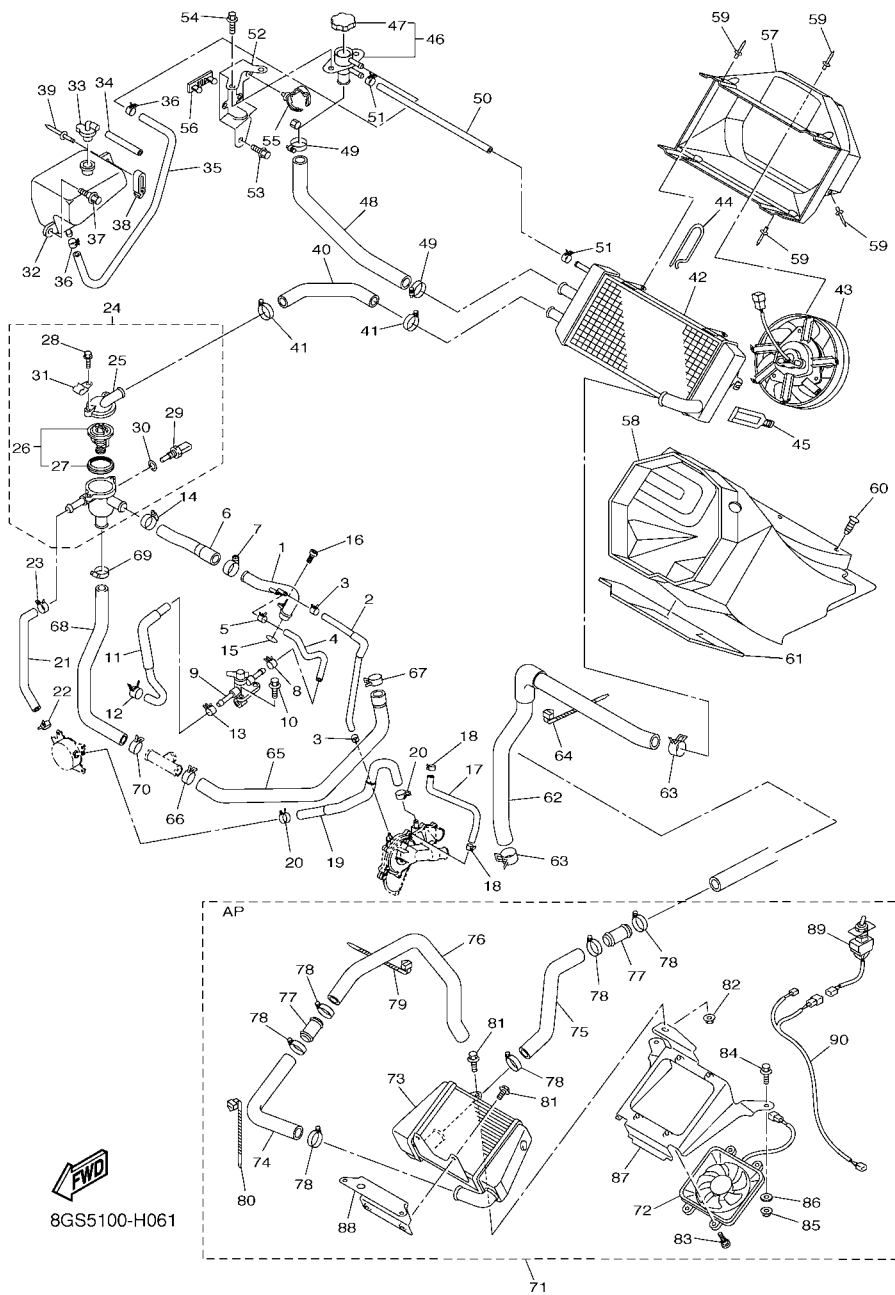
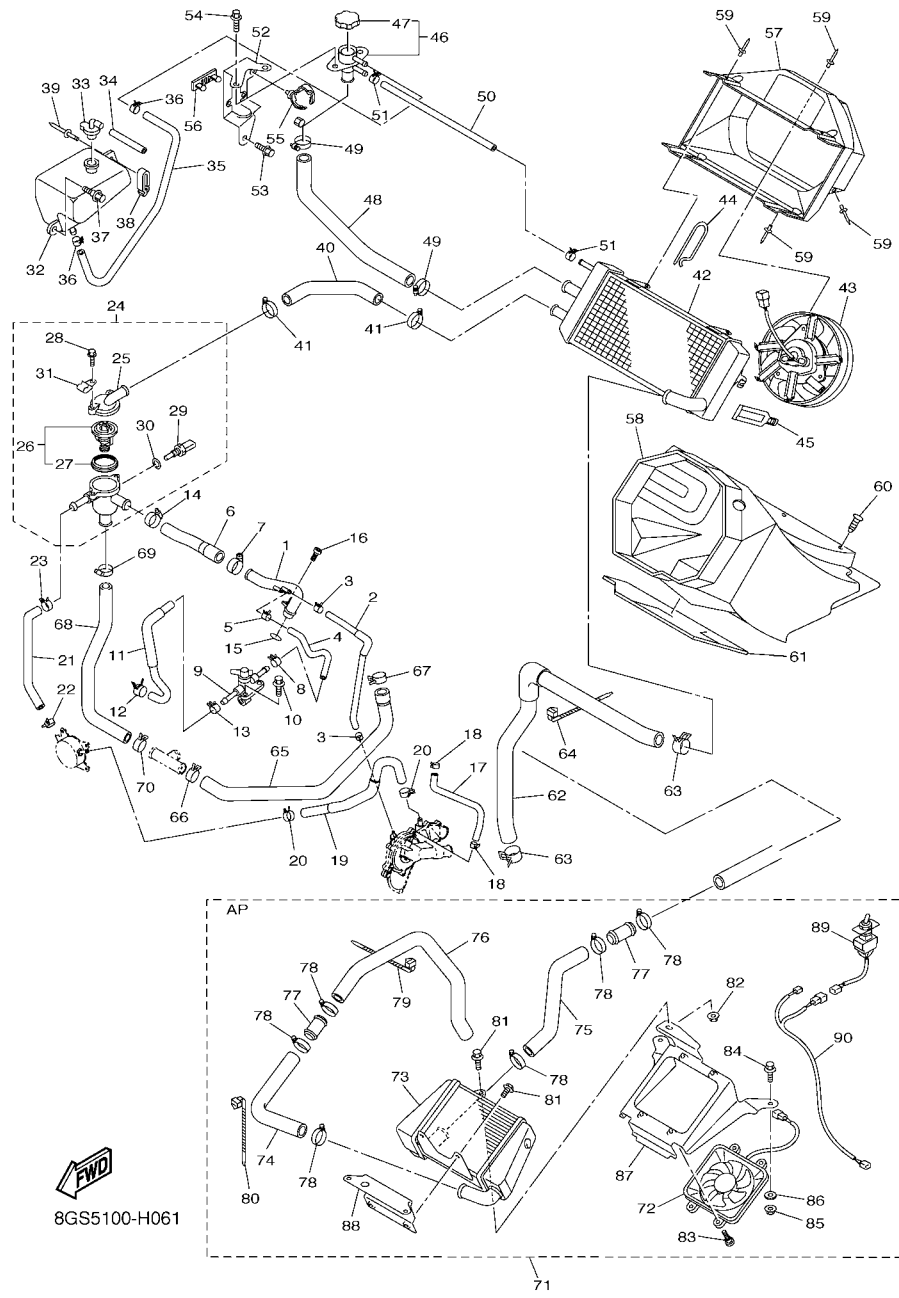
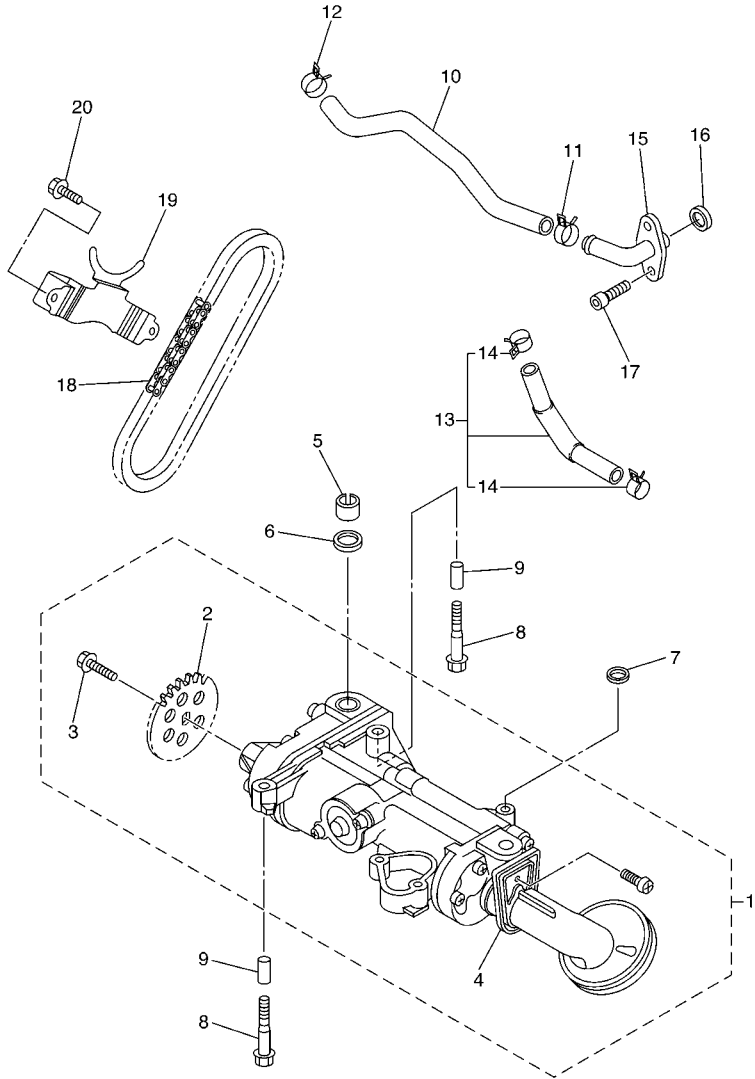

FIG. 6 RADIATOR & HOSE

REF. NO.	PART NO.	DESCRIPTION	8GSC	8GSD		REMARKS
82	95702-06500	.NUT, FLANGE	1	1		AP
83	90149-05129	.SCREW	4	4		AP
84	95822-08016	.BOLT, FLANGE	2	2		AP
85	95702-08500	.NUT, FLANGE	2	2		AP
86	90201-08784	.WASHER, PLATE	2	2		AP
87	8FN-1244F-00	.BRACKET 2	1	1		AP
88	8FN-12464-00	.STAY, RADIATOR	1	1		AP
89	8CN-82917-01	.SWITCH	1	1		AP
90	8FN-82509-00	.WIRE, SUB LEAD	1	1		AP



FWD
8GS5100-H061



8GS3100-G070

FIG. 7 OIL PUMP

REF. NO.	PART NO.	DESCRIPTION	8GSC	8GSD	REMARKS
1	8ES-13300-00	OIL PUMP ASSY	1	1	
2	4XV-13355-00	.SPROCKET, DRIVEN	1	1	
3	90105-06066	.BOLT, FLANGE	1	1	
4	8ES-13427-00	.SPACER, STRAINER	1	1	
5	8ES-13284-00	PIPE	1	1	
6	93210-18322	O-RING	1	1	
7	93210-14579	O-RING	1	1	
8	95812-06040	BOLT, FLANGE	5	5	
9	91808-22019	PIN, DOWEL	2	2	
10	8FN-13464-00	HOSE, OIL 1	1	1	
11	90467-22097	CLIP	1	1	
12	90467-22097	CLIP	1	1	
13	8FN-1319B-02	HOSE SUB-ASSY., 2	1	1	
14	90467-22097	.CLIP	2	2	
15	8ES-13115-00	CONNECTOR, SUCTION PIPE	1	1	
16	93210-16629	O-RING	1	1	
17	91312-06016	BOLT	2	2	
18	94580-25064	CHAIN	1	1	
19	8ES-13898-00	HOLDER	1	1	
20	95812-06012	BOLT, FLANGE	2	2	

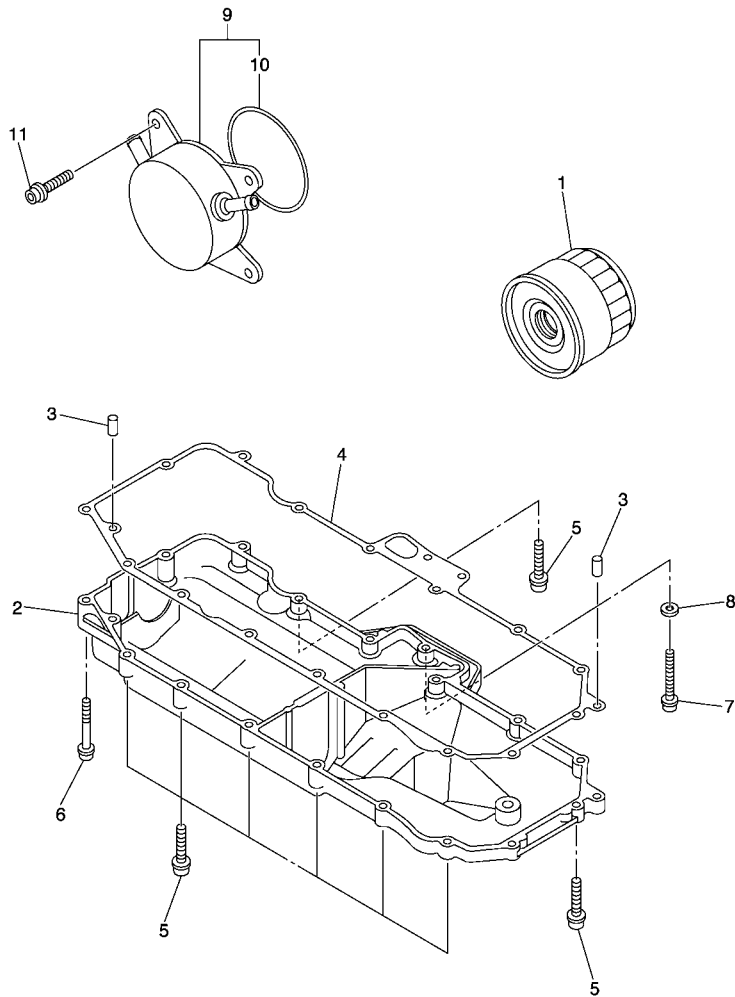
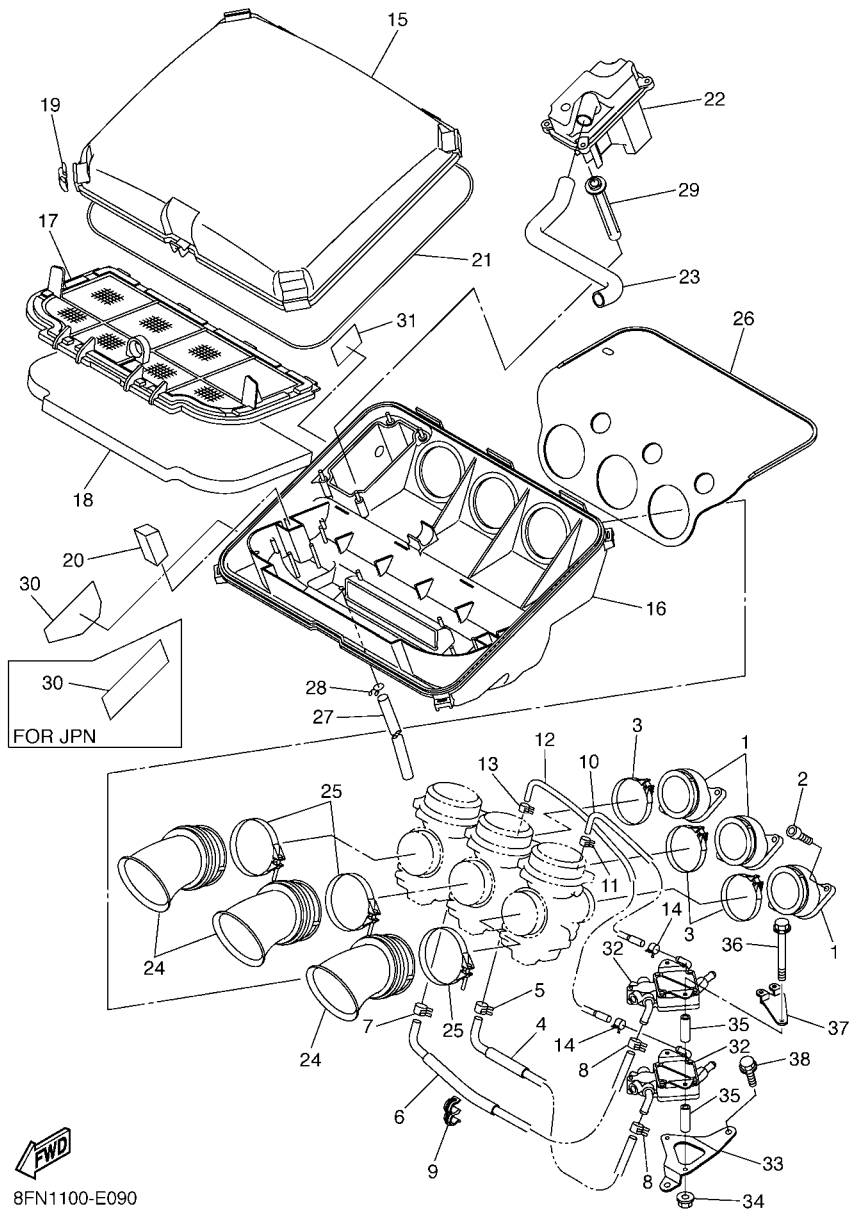

FIG. 8 OIL CLEANER

REF. NO.	PART NO.	DESCRIPTION	8GSC	8GSD		REMARKS
1	5DM-13440-00	ELEMENT ASSY, OIL CLEANER	1	1		
2	8ES-13417-00	COVER, STRAINER	1	1		
3	99530-08012	PIN, DOWEL	2	2		
4	8ES-13414-01	GASKET, STRAINER COVER	1	1		
5	90109-06015	BOLT	15	15		
6	90109-06081	BOLT	2	2		
7	90109-06031	BOLT	1	1		
8	90430-06192	GASKET	1	1		
9	8ES-13470-01	OIL COOLER ASSY	1	1		
10	5JW-13473-00	.O-RING	1	1		
11	90110-06164	BOLT, HEXAGON SOCKET HEAD	4	4		



8GF3100-F080



8FN1100-E090

FIG. 9 INTAKE

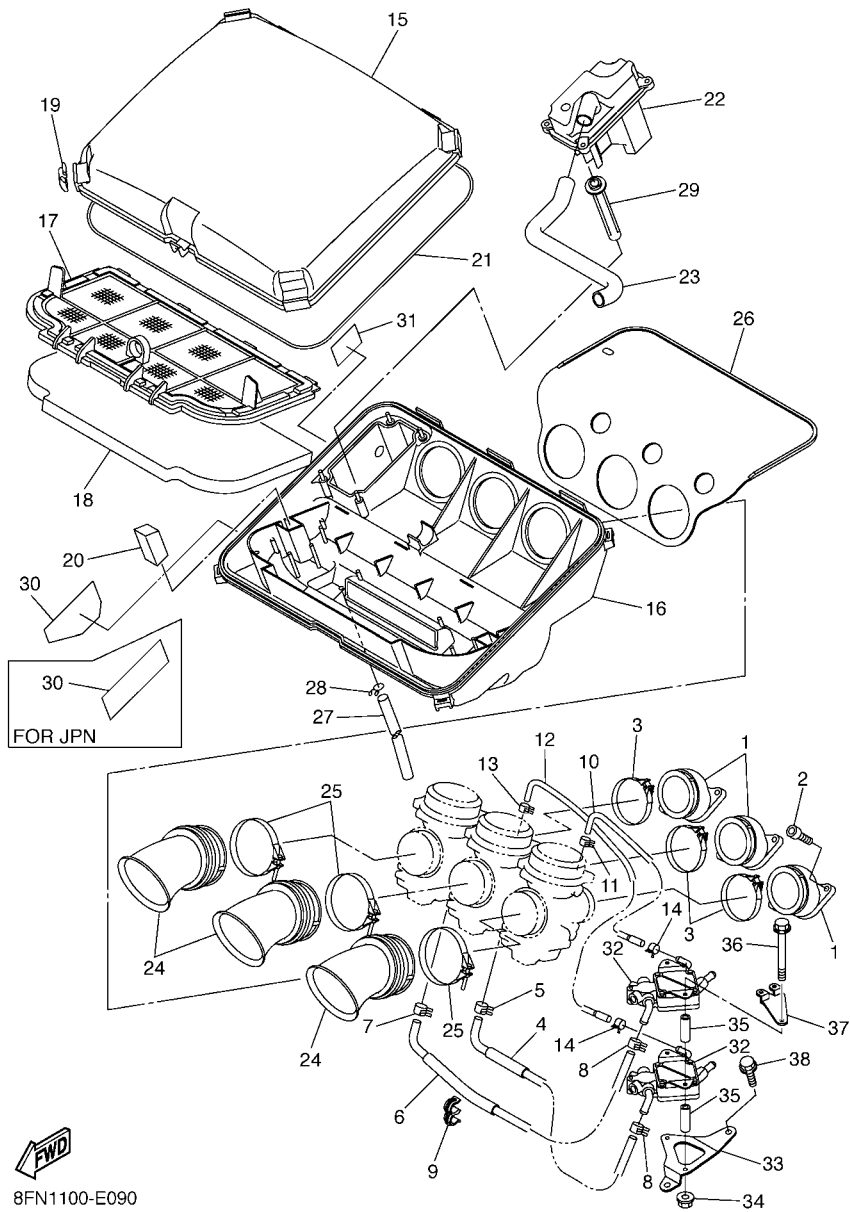
REF. NO.	PART NO.	DESCRIPTION	8GSC	8GSD	REMARKS
1	8ES-13586-10	JOINT, CARBURETOR 1	3	3	
2	91312-06020	BOLT	6	6	
3	90450-57016	HOSE CLAMP ASSY	3	3	
4	8ES-14294-10	HOSE	1		
	8ES-14294-00	HOSE		1	
5	90467-11028	CLIP	1	1	
6	8ES-14298-10	PIPE	1		
	8ES-14298-00	PIPE		1	
7	90467-11028	CLIP	1	1	
8	90467-11028	CLIP	2	2	
9	90464-13194	CLAMP	1	1	
10	8ES-13895-00	HOSE, AIR	1	1	
11	90467-08092	CLIP	1	1	
12	8ES-13892-00	HOSE, AIR 2	1	1	
13	90467-08092	CLIP	1	1	
14	90467-09026	CLIP	2	2	
15	8ES-14431-00	SILENCER, INTAKE 1	1	1	
16	8ES-14441-00	SILENCER, INTAKE 2	1	1	
17	8FN-14472-00	PLATE, ELEMENT	1	1	
18	8ES-14451-00	ELEMENT, AIR CLEANER	1	1	
19	8FA-14436-00	HOOK	4	4	
20	8ES-14425-00	DAMPER 1	2	2	
21	8ES-14452-00	SEAL	1	1	
22	8ES-1441A-00	COVER, CLEANER CASE 1	1	1	
23	8ES-14419-00	PIPE	1	1	
24	8ES-14453-00	JOINT, AIR CLEANER 1	3	3	
25	90450-67003	HOSE CLAMP ASSY	3	3	



FWD
8FN1100-E090

FIG. 9 INTAKE

REF. NO.	PART NO.	DESCRIPTION	8GSC	8GSD		REMARKS
26	8ES-14283-00	COVER, CARBURETOR 1	1	1		
27	90445-11M52	HOSE (L150)	1	1		
28	90467-10041	CLIP	1	1		
29	8ES-14148-00	PIPE	1	1		
30	8GS-2815J-E0	LABEL, NOTICE BREATHER PIPE	1			
	8GS-2815J-S0	LABEL, NOTICE BREATHER PIPE		1		UR FOR EUR,RUS
	8GS-2815J-J0	LABEL, NOTICE BREATHER PIPE		1		UR FOR JPN
31	8ES-14427-00	LABEL, INSTRUCTION	1	1		
32	8FA-13910-00	FUEL PUMP ASSY	2	2		
33	8FA-24491-00	BRACKET, FUEL PUMP	1	1		
34	95702-06500	NUT, FLANGE	2	2		
35	90387-065V0	COLLAR	4	4		
36	95022-06085	BOLT, FLANGE	2	2		
37	8FN-12443-00	STAY	1	1		
38	95822-06016	BOLT, FLANGE	2	2		

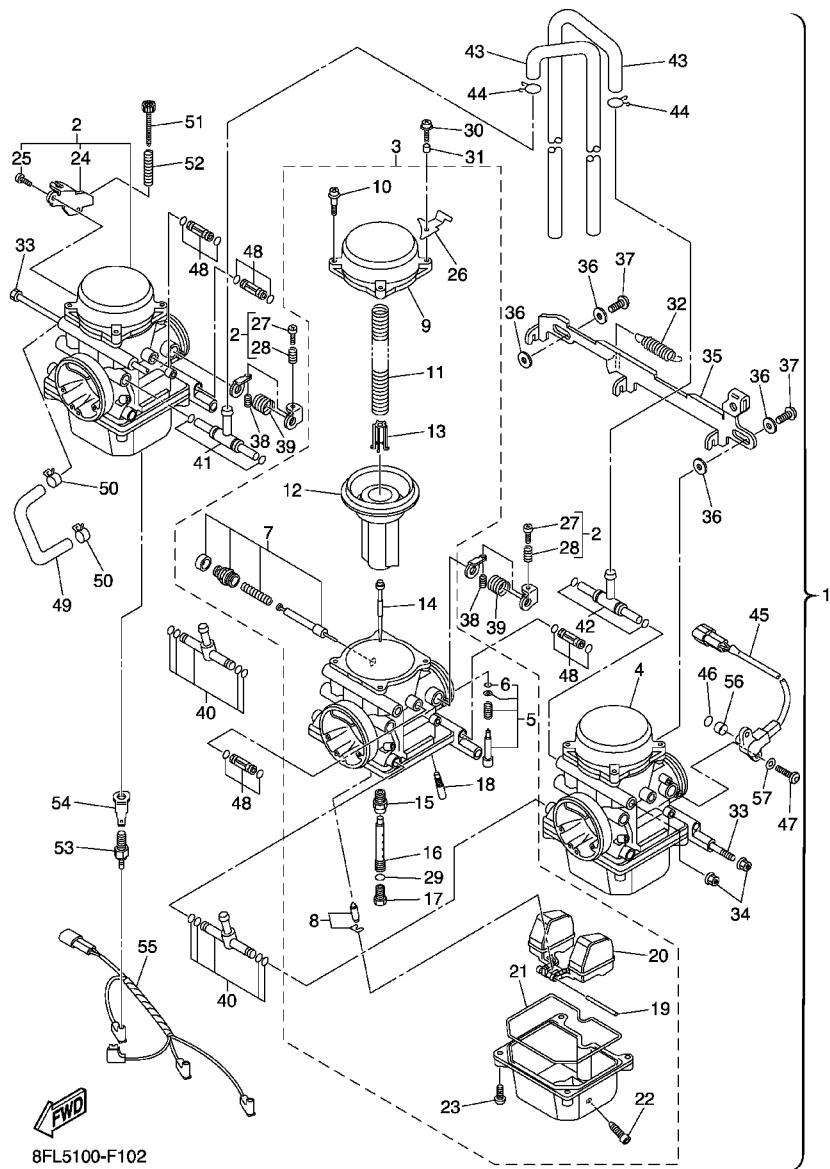

8FL5100-F102

FIG. 10 CARBURETOR

REF. NO.	PART NO.	DESCRIPTION	8GSC	8GSD	REMARKS
1	8ES-14900-02	CARBURETOR ASSY	1	1	
2	8ES-14901-01	.CARBURETOR ASSY 1	1	1	
3	8ES-14902-01	.CARBURETOR ASSY 2	1	1	
4	8ES-14903-01	.CARBURETOR ASSY 3	1	1	
5	8ES-14105-00	..PILOT SCREW SET	1	1	
6	8ES-14147-00	..O-RING	1	1	
7	8ES-1410A-00	..STARTER SET	1	1	
8	8ES-14107-00	..NEEDLE VALVE SET	1	1	
9	8ES-14958-00	..COVER, DIAPHRAGM	1	1	
10	4JH-14216-00	..SCREW	4	4	#1,3
	4JH-14216-00	..SCREW	3	3	#2
11	8ES-14933-00	..SPRING, DIAPHRAGM	1	1	
12	8ES-14940-00	..DIAPHRAGM ASSY	1	1	
13	4JH-14936-00	..SEAT, SPRING	1	1	
14	8ES-14916-00	..JET NEEDLE COMP.	1	1	
15	8ES-14947-00	..JET, NEEDLE	1	1	
16	8ES-1414G-00	..PIPE, MAIN BLEED	1	1	
17	3TJ-14943-87	..JET, MAIN (#148)	1	1	STD
	3TJ-14943-36	..JET, MAIN (#145)	1	1	AP
	3TJ-14943-37	..JET, MAIN (#150)	1	1	AP
18	8ES-14948-05	..JET (#45)	1	1	STD
	8ES-14948-03	..JET (#40)	1	1	AP
	8ES-14948-06	..JET (#48)	1	1	AP
	8ES-14948-07	..JET (#50)	1	1	AP
19	676-14548-00	..PIN, FLOAT ARM	1	1	
20	8ES-14985-00	..FLOAT	1	1	
21	8ES-14984-00	..GASKET, FLOAT CHAMBER	1	1	

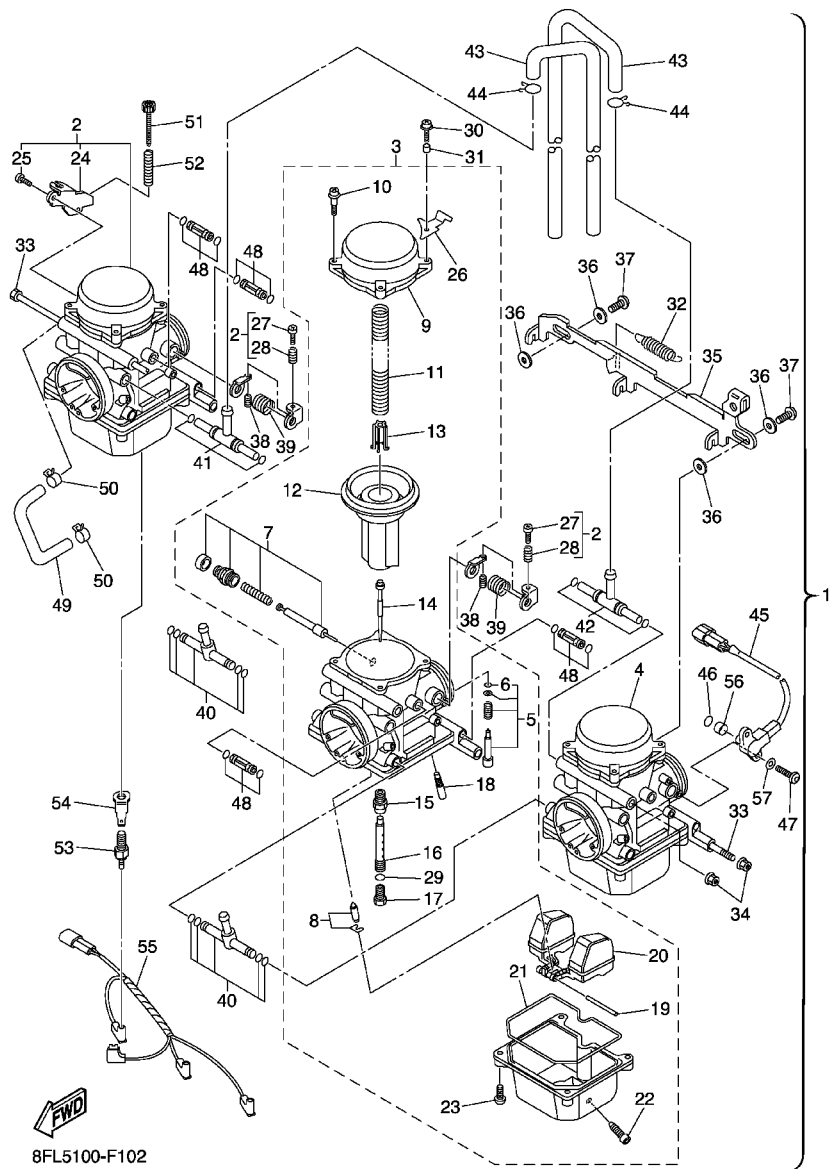

8FL5100-F102

FIG. 10 CARBURETOR

REF. NO.	PART NO.	DESCRIPTION	8GSC	8GSD	REMARKS
22	3TJ-14191-40	..PLUG, DRAIN	1	1	
23	98502-04014	..SCREW, PAN HEAD	4	4	
24	8ES-14926-01	..BRACKET, THROTTLE 1	1	1	#1
25	8ES-14592-00	..SCREW	1	1	#1
26	4TV-14926-00	..BRACKET, THROTTLE 1	1	1	#2
27	4JH-14121-00	..SCREW, THROTTLE STOP	1	1	#1,2
28	7A9-14555-00	..SPRING	1	1	#1,2
29	8ES-14561-00	..O-RING	1	1	
30	8ES-14565-00	.SCREW	1	1	
31	4JH-14264-00	.COLLAR	1	1	
32	8ES-14935-00	.SPRING	1	1	
33	8ES-14162-00	.BOLT, HOLDING	2	2	
34	4JH-14358-00	.NUT	2	2	
35	8ES-14965-00	.LEVER, STARTER	1	1	
36	8ES-14578-00	.COLLAR	4	4	
37	8ES-14567-00	.SCREW	2	2	
38	4YR-14133-00	.SPRING, THROTTLE STOP	2	2	
39	4JH-14487-00	.SPRING	2	2	
40	8ES-14295-00	.PIPE, FUEL	2	2	
41	8ES-13815-00	.JOINT 1	1	1	
42	8ES-13816-00	.JOINT 2	1	1	
43	8ES-14197-01	.PIPE	2	2	
44	3TJ-14937-40	.CLIP	2	2	
45	8ES-85885-01	.THROTTLE SENSOR ASSY	1	1	
46	4TV-14562-00	.O-RING	1	1	
47	4YR-14216-00	.SCREW	2	2	
48	8ES-14454-00	.JOINT	4	4	

FIG. 10 CARBURETOR

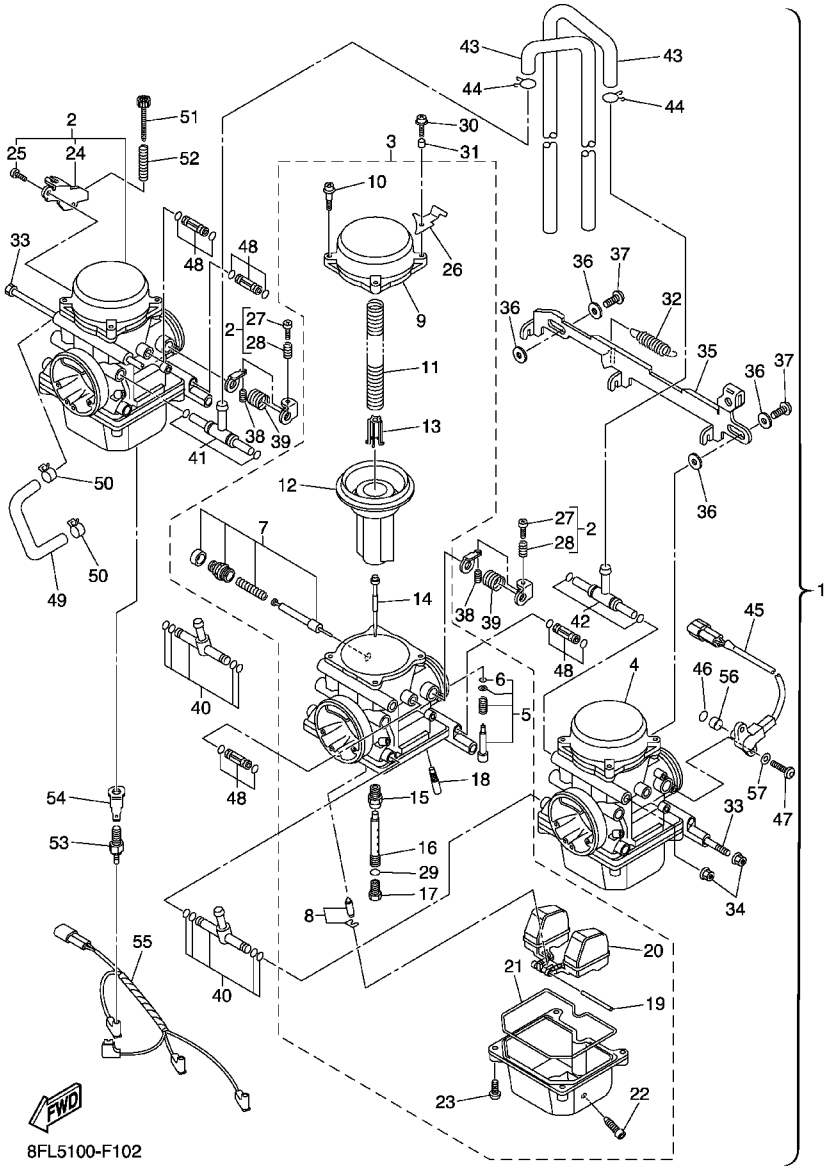

REF. NO.	PART NO.	DESCRIPTION	8GSC	8GSD	REMARKS
49	8ES-14987-00	.HOSE	1	1	
50	4TV-12486-00	.CLIP	2	2	
51	8ES-14121-00	.SCREW, THROTTLE STOP	1	1	
52	4YR-14934-00	.SPRING, THROTTLE STOP	1	1	
53	5FU-83790-20	.HEATER ASSY (30W)	3	3	
54	8FA-82103-00	.TERMINAL 1	1	1	
55	8ES-81517-01	.WIRE, SUB LEAD	1	1	
56	4TV-14534-00	.COLLAR	1	1	
57	4YR-14557-00	.WASHER	2	2	

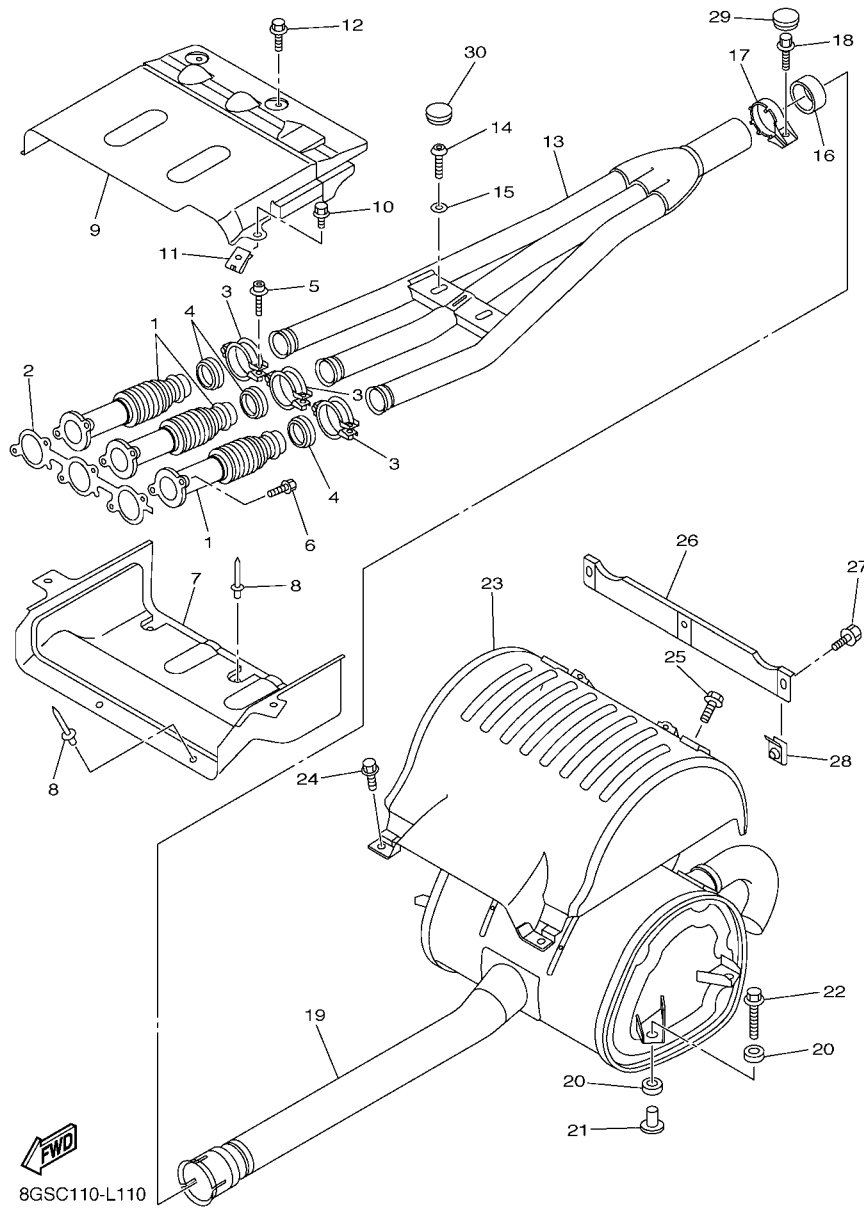
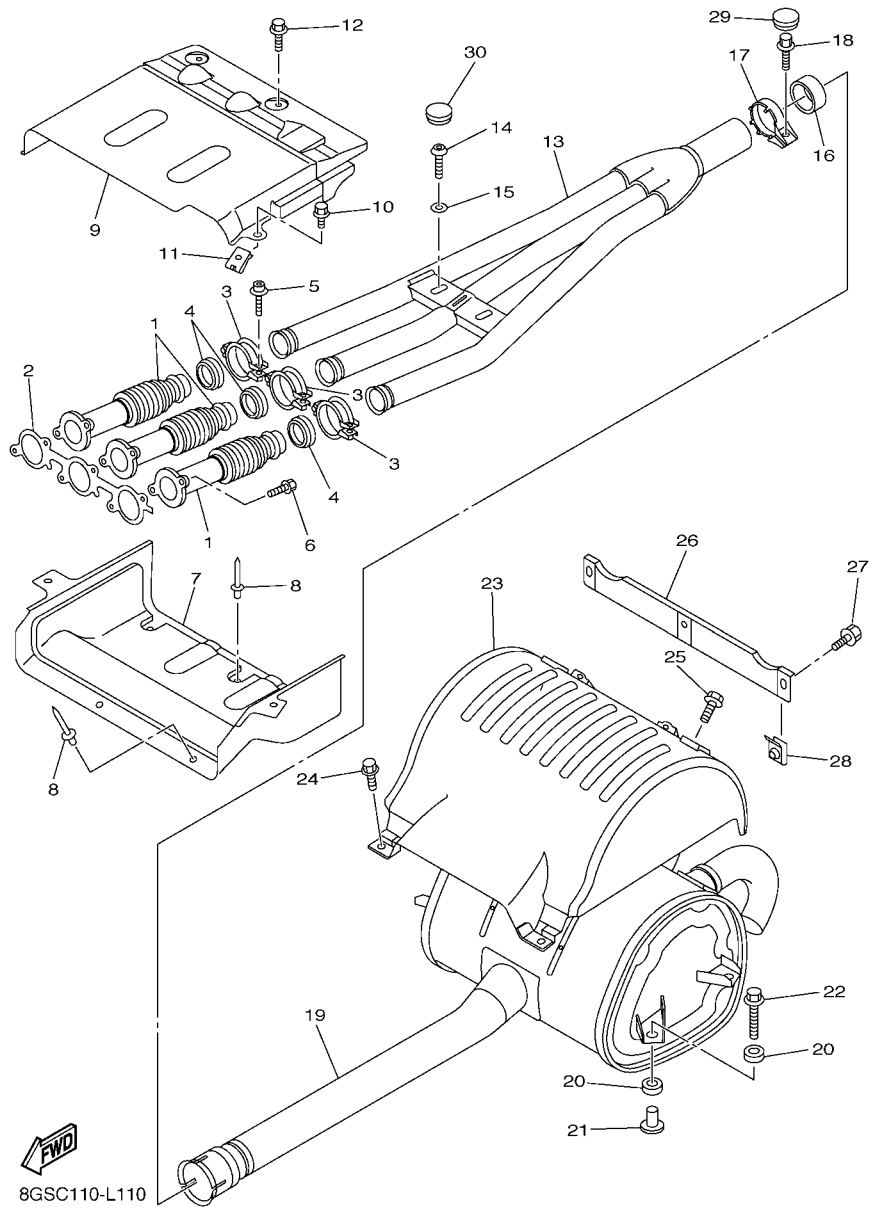

FIG. 11 EXHAUST

REF. NO.	PART NO.	DESCRIPTION	8GSC	8GSD	REMARKS
1	8ES-14615-01	JOINT, EXHAUST 1	3	3	
2	8ES-14613-00	GASKET, EXHAUST PIPE	1	1	
3	8FA-14715-00	BAND, MUFFLER	3	3	
4	8FA-14623-10	GASKET, EXHAUST PIPE	3	3	
5	90109-06031	BOLT	3	3	
6	95022-08020	BOLT, FLANGE	6	6	
7	8ES-14627-00	COVER, EXHAUST	1	1	
8	90267-47195	RIVET, BLIND(4.7X16.4 YELLOW)	3	3	
9	8FN-14637-00	EXHAUST COVER ASS'Y	1	1	
10	95812-06008	BOLT, FLANGE	2	2	
11	90183-060A0	NUT, SPRING	2	2	
12	95812-06016	BOLT, FLANGE	2	2	
13	8ES-14610-00	EXHAUST PIPE ASSY 1	1	1	
14	92012-08025	BOLT, BUTTON HEAD	2	2	
15	92990-08200	WASHER, PLAIN	2	2	
16	8FA-14714-10	GASKET, MUFFLER	1	1	
17	8FA-14788-00	BAND, SILENCER	1	1	
18	95812-08020	BOLT, FLANGE	1	1	
19	8FN-14750-00	SILENCER ASSY	1	1	
20	8FA-14737-00	DAMPER, MUFFLER	8	8	
21	90387-08071	COLLAR	4	4	
22	90119-08112	BOLT, WITH WASHER	4	4	
23	8ES-14708-02	PROTECTOR ASSY	1	1	
24	90119-06179	BOLT, WITH WASHER	2	2	
25	95812-06008	BOLT, FLANGE	2	2	
26	8ES-1478N-00	PLATE, 8	1	1	
27	95812-06008	BOLT, FLANGE	3	3	



8GSC110-L110

FIG. 11 EXHAUST

REF. NO.	PART NO.	DESCRIPTION	8GSC	8GSD		REMARKS
28	90183-060A0	NUT, SPRING	3	3		
29	90338-20004	PLUG	1	1		
30	90338-20007	PLUG	2	2		

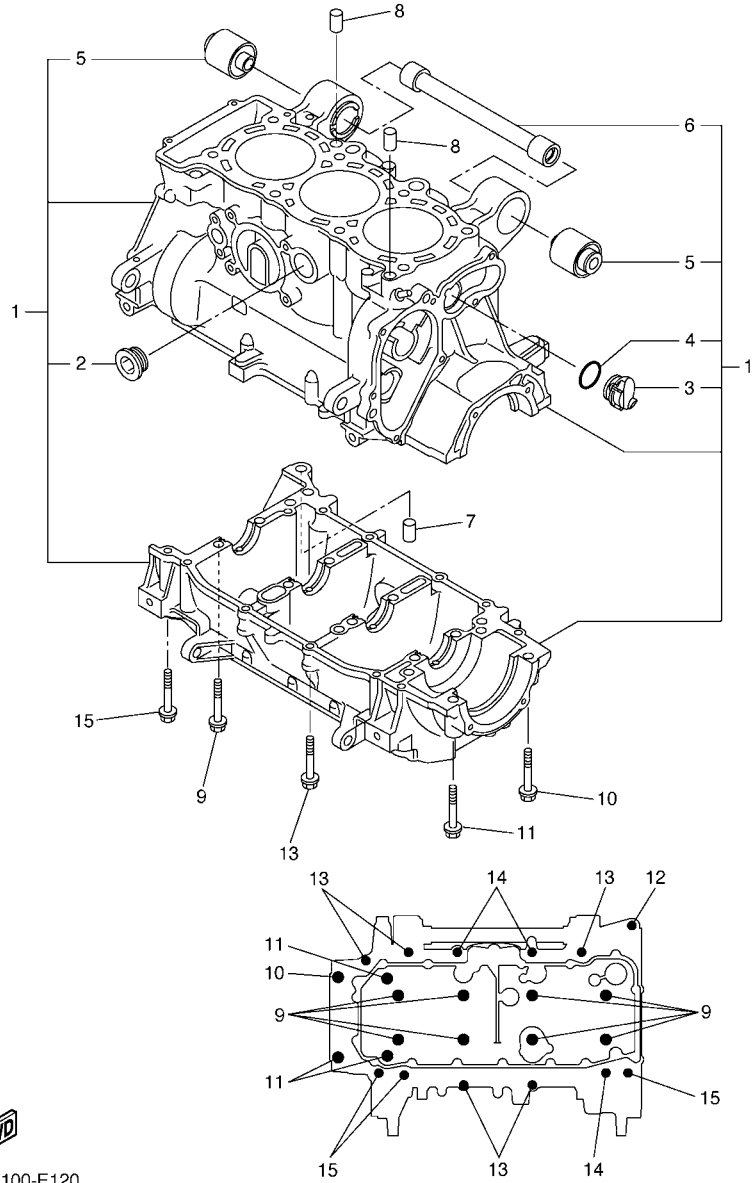

8FJ3100-E120

FIG. 12 CRANKCASE

REF. NO.	PART NO.	DESCRIPTION	8GSC	8GSD	REMARKS
1	8ES-15100-08	CRANKCASE ASSY	1	1	
2	90340-27129	.PLUG, STRAIGHT SCREW	1	1	
3	8ES-15167-00	.PLUG, BLIND 1	1	1	
4	93210-24709	.O-RING	1	1	
5	8FA-2139X-00	.DAMPER	2	2	
6	8ES-21459-00	.SPACER	1	1	
7	99530-10014	PIN, DOWEL	1	1	
8	99530-10114	PIN, DOWEL	2	2	
9	90119-09004	BOLT, WITH WASHER	8	8	
10	95812-08055	BOLT, FLANGE	1	1	
11	95812-08070	BOLT, FLANGE	3	3	
12	90109-06185	BOLT	1	1	
13	95812-06055	BOLT, FLANGE	5	5	
14	95812-06080	BOLT, FLANGE	3	3	
15	90105-06123	BOLT, FLANGE	3	3	



8ES1100-D130

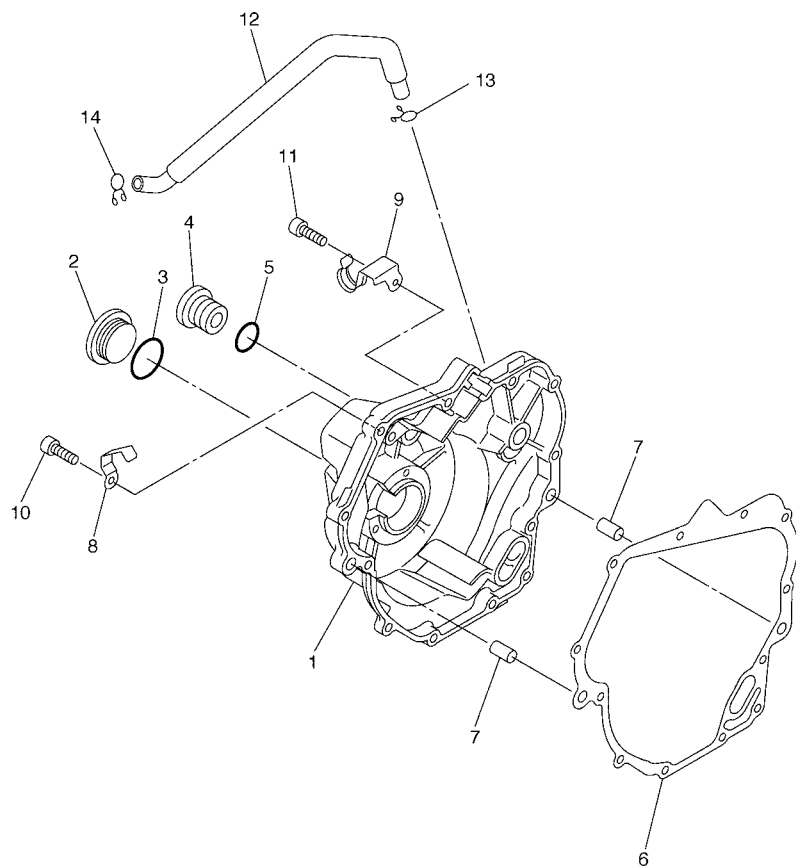

FIG. 13 CRANKCASE COVER 1

REF. NO.	PART NO.	DESCRIPTION	8GSC	8GSD		REMARKS
1	8ES-15421-01	COVER, CRANKCASE 2	1	1		
2	90340-32080	PLUG, STRAIGHT SCREW	1	1		
3	93210-32172	O-RING	1	1		
4	90340-14117	PLUG, STRAIGHT SCREW	1	1		
5	93210-14369	O-RING	1	1		
6	8ES-15461-01	GASKET, CRANKCASE COVER 2	1	1		
7	99530-08012	PIN, DOWEL	2	2		
8	90462-08225	CLAMP	1	1		
9	90465-10038	CLAMP	1	1		
10	90109-06015	BOLT	11	11		
11	90110-06234	BOLT, HEXAGON SOCKET HEAD	1	1		
12	8ES-1531A-00	HOSE, BREATHER 1	1	1		
13	90467-100A1	CLIP	1	1		
14	90467-11019	CLIP	1	1		



8GM1100-G140

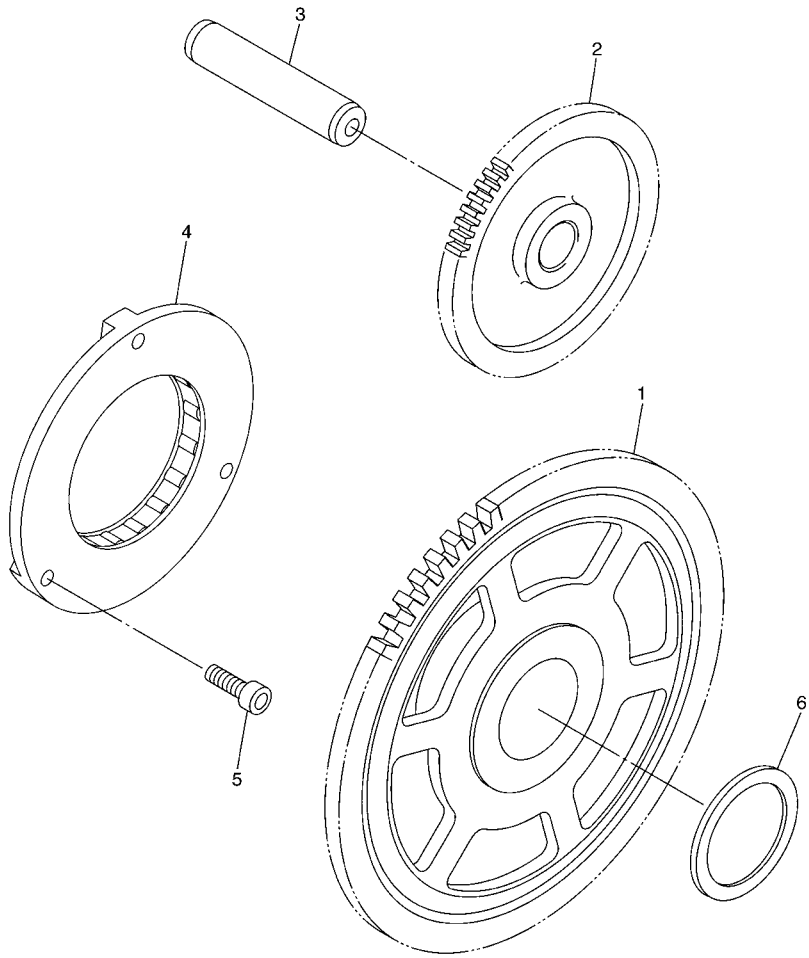
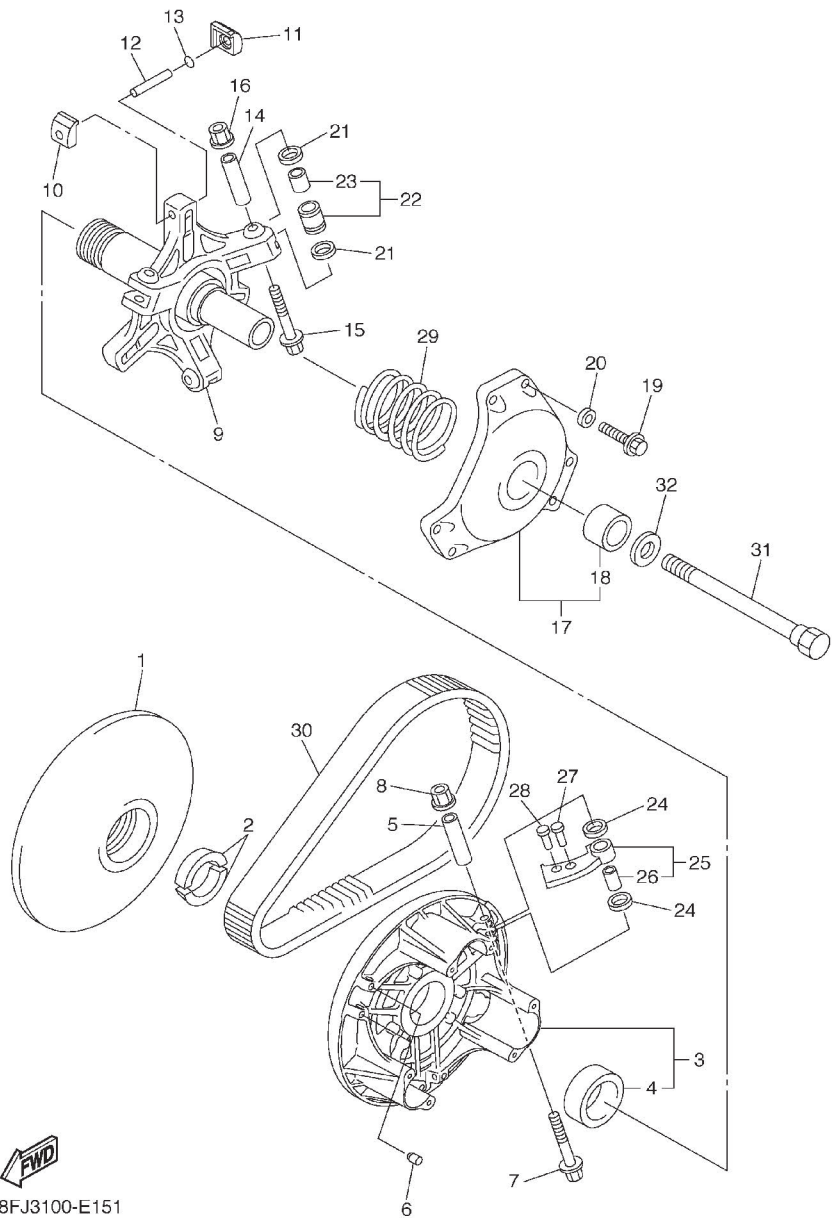

FIG. 14 STARTER

REF. NO.	PART NO.	DESCRIPTION	8GSC	8GSD				REMARKS
1	8FA-15515-00	GEAR 3	1	1				
2	8ES-15512-01	GEAR, IDLER 1	1	1				
3	8ES-15521-00	SHAFT 1	1	1				
4	8GL-15590-00	STARTER ONE-WAY ASSY	1	1				
5	90110-06168	BOLT, HEXAGON SOCKET HEAD	3	3				
6	90201-30013	WASHER, PLATE	1	1				



8FJ3100-E151

FIG. 15 PRIMARY SHEAVE

REF. NO.	PART NO.	DESCRIPTION	8GSC	8GSD	REMARKS
1	8FA-17611-01	SHEAVE, PRIMARY FIXED	1	1	
2	8V0-17639-00	STOPPER	2	2	
3	8FP-17620-00	PRIMARY SLIDING SHEAVE COMP.	1	1	
4	90384-41242	.BUSH, BIMETAL FORMED	1	1	
5	90387-0514T	COLLAR	3	3	
6	90113-05053	BOLT, SET	6	6	
7	90105-05644	BOLT, FLANGE	3	3	
8	95602-05200	NUT, SELF-LOCKING	3	3	
9	8GS-17640-02	SPIDER COMPLETE	1	1	
10	8BW-17653-00	SLIDER	3	3	
11	8ES-17653-00	SLIDER	3	3	
12	91609-50032	PIN, SPRING	3	3	
13	8ES-17655-00	DAMPER, SLIDER	3	3	
14	90387-0514U	COLLAR	3	3	
15	90105-05644	BOLT, FLANGE	3	3	
16	95602-05200	NUT, SELF-LOCKING	3	3	
17	8DF-17630-00	PRIMARY SHEAVE CAP COMP.	1	1	
18	90380-28237	.BUSH, SOLID	1	1	
19	97017-06030	BOLT	6	6	
20	92907-06600	WASHER, PLATE	6	6	
21	90202-09227	WASHER, PLATE	6	6	
22	8FG-17624-20	ROLLER, COMP	3	3	
23	90386-09001	.BUSH	1	1	
24	90202-08204	WASHER, PLATE	6	6	
25	8FN-17605-00	WEIGHT COMP	3	3	
26	90386-08002	.BUSH	1	1	
27	90269-06006	RIVET (ST17.2MM)	3	3	IN

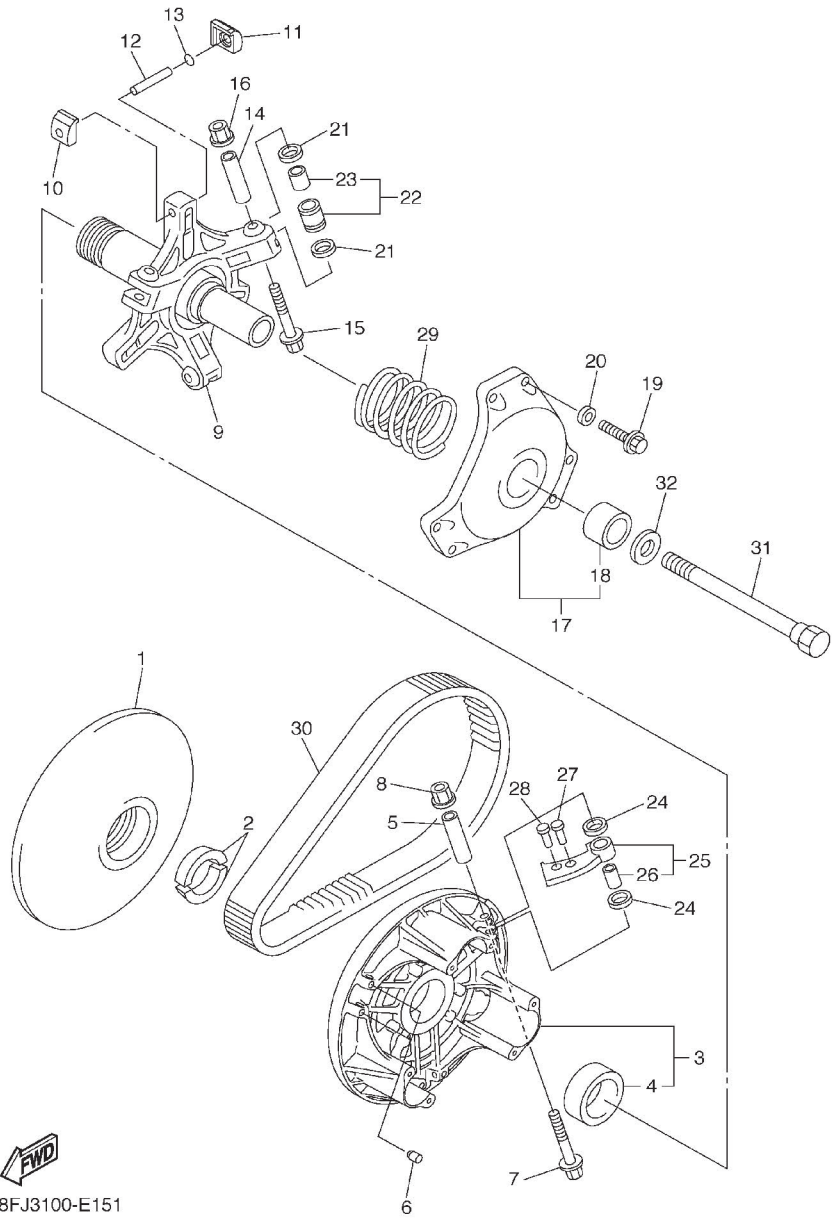

8FJ3100-E151

FIG. 15 PRIMARY SHEAVE

REF. NO.	PART NO.	DESCRIPTION	8GSC	8GSD	REMARKS
28	90261-06033	RIVET, COUNTERSUNK (ST17.2MM)	3	3	OUT
29	90501-550A3	SPRING, COMPRESSION	1	1	(WH-BL-WH)
30	8GS-17641-00	V-BELT	1	1	
31	8V0-17647-00	BOLT (L=156.5MM)	1	1	
32	92907-16100	WASHER	1	1	

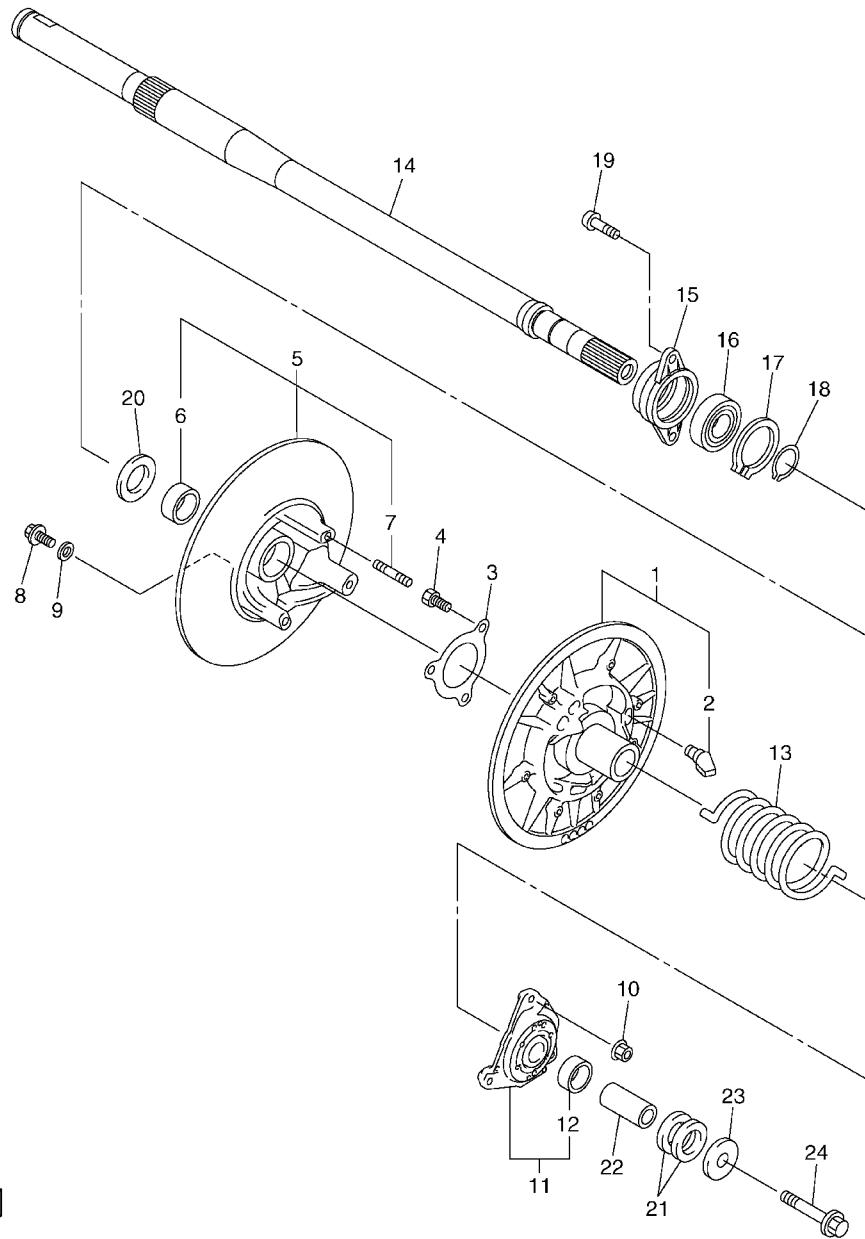
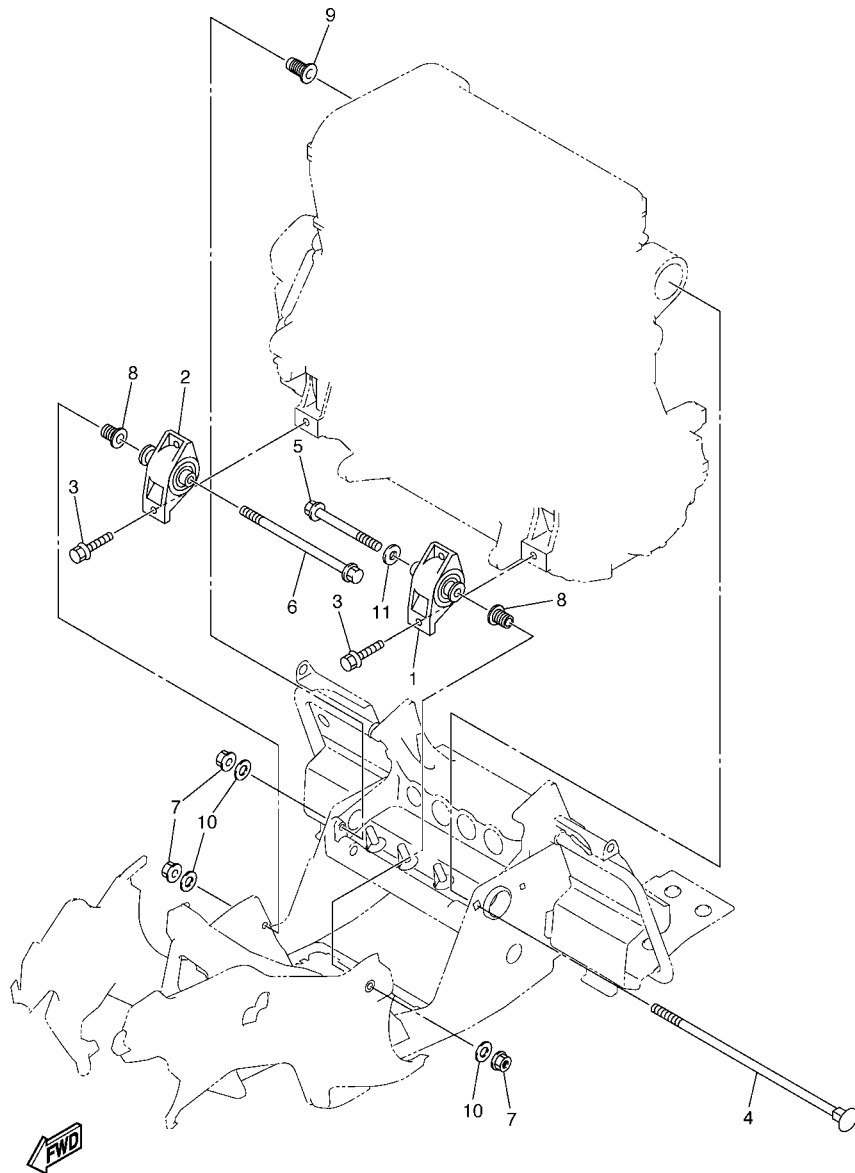

FIG. 16 SECONDARY SHEAVE

REF. NO.	PART NO.	DESCRIPTION	8GSC	8GSD	REMARKS
1	8CR-17660-30	SECONDARY FIXED SHEAVE COMP.	1	1	
2	8AV-17688-10	.SHOE, RAMP	3	3	
3	8BV-17656-00	STOPPER, HOLDER	1	1	
4	90154-06062	SCREW, BINDING	3	3	
5	8BU-17670-30	SECONDARY SLIDING SHEAVE	1	1	
6	90384-38243	.BUSH, BIMETAL FORMED	1	1	
7	95617-08630	.BOLT, STUD	3	3	
8	90105-06734	BOLT, FLANGE	3	3	
9	90201-06037	WASHER, PLATE (T=1.0)	3	3	UR UN
	90201-061H1	WASHER, PLATE (T=0.5)	3	3	UR UN
10	90179-08655	NUT	3	3	
11	8BV-17604-91	SEAT SPRING SET	1	1	
12	90384-38243	.BUSH, BIMETAL FORMED	1	1	
13	90508-60018	SPRING, TORSION	1	1	(P-P)
14	8GS-17681-01	SHAFT, SECONDARY	1	1	
15	8FN-47631-00	HOUSING, BEARING	1	1	
16	93306-30579	BEARING	1	1	
17	99009-62500	CIRCLIP	1	1	
18	99009-25400	CIRCLIP	1	1	
19	90149-08034	SCREW	2	2	
20	90201-25526	WASHER, PLATE (T2.0)	2	2	UN
21	90201-225A4	WASHER, PLATE (T=1.0)	3	3	UR UN
	90201-222F0	WASHER, PLATE (T=0.5)	1	1	UR UN
22	90387-1407L	COLLAR	1	1	
23	90201-141A3	WASHER, PLATE	1	1	
24	90105-14766	BOLT, FLANGE	1	1	



8GS1100-F161



8FN1100-E170

FIG. 17 ENGINE BRACKET

REF. NO.	PART NO.	DESCRIPTION	8GSC	8GSD	REMARKS
1	8ES-21410-00	ENGINE BRACKET COMP.	1	1	
2	8ES-21420-00	ENGINE BRACKET COMP. 2	1	1	
3	95812-08030	BOLT, FLANGE	4	4	
4	8FN-21481-00	BOLT, ENGINE MOUNTING 1	1	1	
5	95817-12100	BOLT, FLANGE	1	1	
6	95817-12200	BOLT, FLANGE	1	1	
7	90179-12004	NUT	3	3	
8	8FG-21495-00	BOLT, ENGINE ADJUSTING	2	2	
9	8FG-2149C-00	BOLT	1	1	
10	90201-120T5	WASHER, PLATE	3	3	
11	90201-125A3	WASHER, PLATE	1	1	

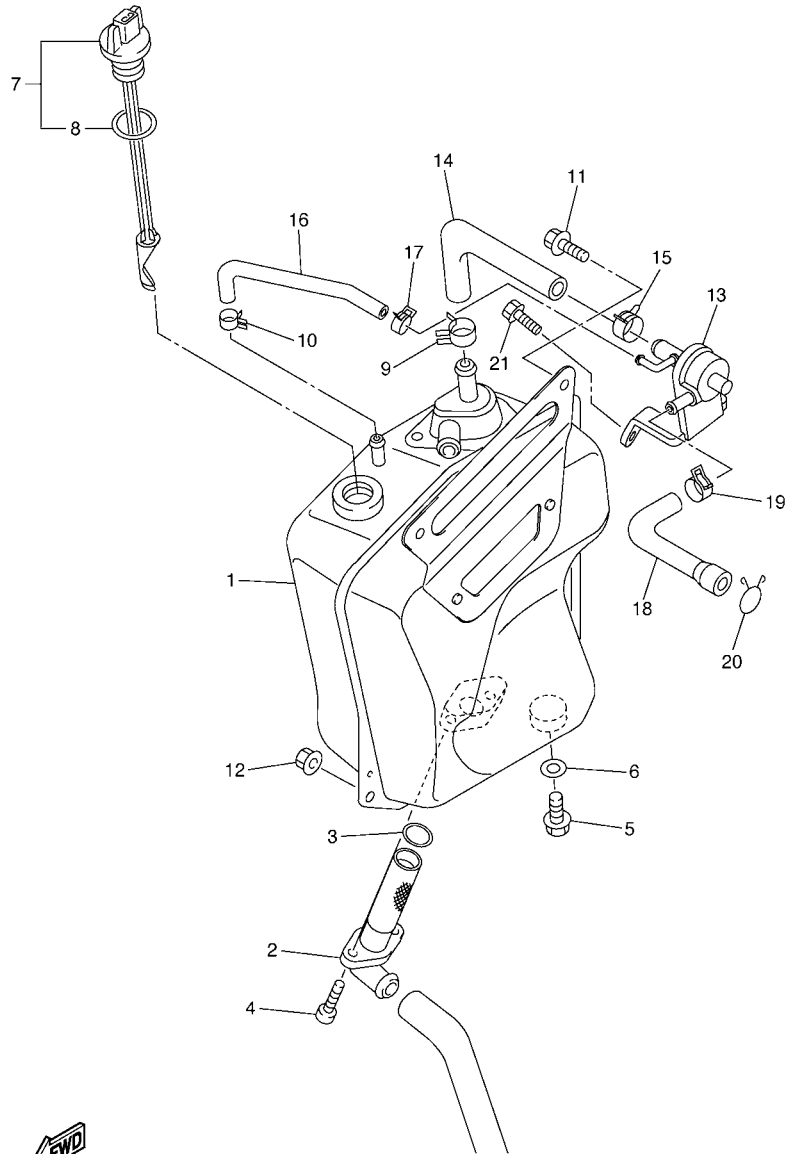

8FN1100-E180

FIG. 18 OIL TANK

REF. NO.	PART NO.	DESCRIPTION	8GSC	8GSD	REMARKS
1	8FG-21751-02	TANK, OIL	1	1	
2	8FG-13406-00	OIL PIPE COMP. 2	1	1	
3	93210-19026	O-RING	1	1	
4	91317-06016	BOLT	2	2	
5	95807-08012	BOLT, FLANGE	1	1	
6	90430-08204	GASKET	1	1	
7	8FA-85720-01	OIL LEVEL GAUGE ASSY	1	1	
8	8FP-85075-00	.O-RING	1	1	
9	90468-08104	CLIP	1	1	
10	90467-12053	CLIP	1	1	
11	95812-06016	BOLT, FLANGE	2	2	
12	95602-08200	NUT, SELF-LOCKING	1	1	
13	8FN-13520-00	VALVE ASSY.	1	1	
14	8ES-21745-00	PIPE, OIL TANK BREATHER	1	1	
15	90468-08104	CLIP	1	1	
16	8ES-2174N-00	PIPE, OIL TANK	1	1	
17	90467-12053	CLIP	1	1	
18	8FN-21816-00	PIPE 1	1	1	
19	90467-20085	CLIP	1	1	
20	90467-22080	CLIP	1	1	
21	95822-06020	BOLT, FLANGE	2	2	

FIG. 19 FRAME

REF. NO.	PART NO.	DESCRIPTION	8GSC	8GSD	REMARKS
1	8GS-21940-11	FRONT FRAME COMP.	1	1	
2	8FN-W2197-01	.BULKHEAD	1	1	
3	90381-15001	..BUSH, SOLID	2	2	
4	90381-16004	..BUSH, SOLID	2	2	
5	8FN-W2198-01	.BULKHEAD 2	1	1	
6	90381-15001	..BUSH, SOLID	2	2	
7	90381-16004	..BUSH, SOLID	2	2	
8	90105-08072	.BOLT, FLANGE	4	4	
9	95607-08200	.NUT, SELF-LOCKING	4	4	
10	8FN-21947-00	.BRACKET, STEERING 1	1	1	
11	95607-10200	.NUT, U FLANGE	4	4	
12	8GS-2193A-01	.PROTECTOR	1	1	
13	90267-47195	.RIVET, BLIND(4.7X16.4 YELLOW)	57	57	
14	90267-48016	.RIVET, BLIND (4.8X16.4 YELLOW)	21	21	
15	8FN-2198E-00	.REINFORCEMENT, FRAME 3	1	1	
16	8FN-2194F-00	.BRACKET, ENGINE 2	1	1	
17	8FN-2194G-00	.BRACKET, ENGINE 3	1	1	
18	90267-48176	.RIVET, BLIND (4.8X17 YELLOW)	2	2	
19	90267-48177	.RIVET, BLIND (4.8X14 YELLOW)	1	1	
20	8GS-21950-01	REAR FRAME COMP.	1	1	
21	90267-48023	.RIVET, BLIND(4.8X12.1 YELLOW)	99	99	
22	90267-48177	.RIVET, BLIND (4.8X14 YELLOW)	89	89	
23	8FN-21944-01	.BRACKET,RR.TRACK SUSPENTION 1	1	1	
24	8FN-21954-01	.BRACKET,RR.TRACK SUSPENTION 2	1	1	
25	90176-10075	.NUT, CROWN	6	6	
26	8FN-2194H-00	.PROTECTOR, MUFFLER	1	1	
27	8FN-21926-00	.REINFORCEMENT, FOOTREST 1	1	1	

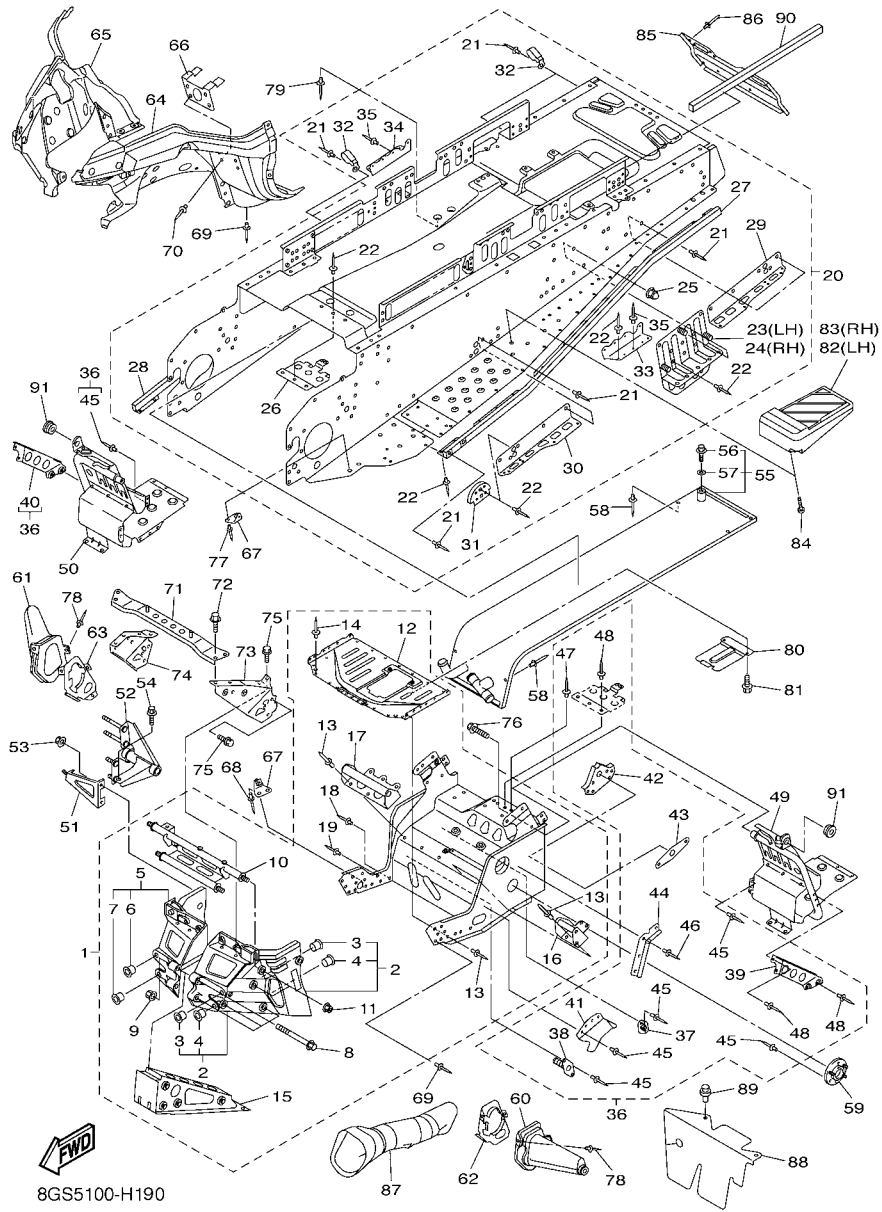

8GS5100-H190

FIG. 19 FRAME

REF. NO.	PART NO.	DESCRIPTION	8GSC	8GSD	REMARKS
28	8FN-21936-00	.REINFORCEMENT, FOOTREST 2	1	1	
29	8FN-21962-01	.PATCH 2	2	2	
30	8FN-21963-01	.PATCH 3	2	2	
31	8CW-21943-00	.BRACKET, MAIN TRACK 1	2	2	
32	90465-08368	.CLAMP	7	7	
33	8GS-21965-00	.PATCH 5	1	1	
34	8GS-21966-00	.PATCH 6	1	1	
35	90267-48176	.RIVET, BLIND (4.8X17 YELLOW)	16	16	
36	8GS-W2195-00	FRAME CONNECTION KIT	1	1	
37	8CR-21939-01	.BRACKET, CHAIN HOUSING	1	1	
38	8FN-21939-00	.BRACKET, CHAIN HOUSING	1	1	
39	8FG-2196M-00	.BRACKET, 5	1	1	
40	8FG-2197M-00	.BRACKET, 6	1	1	
41	8FU-2198G-00	.COVER 2	1	1	
42	8GS-21943-00	.BRACKET, MAIN TRACK 1	2	2	
43	8FN-21953-00	.BRACKET, MAIN TRACK 2	2	2	
44	8FA-21999-00	.CLAMP, WIRE HARNESS	1	1	
45	90267-47195	.RIVET, BLIND(4.7X16.4 YELLOW)	60	60	UN
46	90267-48018	.RIVET, BLIND (4.8X18.6 BLACK)	4	4	
47	90267-48023	.RIVET, BLIND(4.8X12.1 YELLOW)	6	6	
48	90267-48177	.RIVET, BLIND (4.8X14 YELLOW)	10	10	
49	8FN-21960-01	FOOTREST COMP. 1	1	1	
50	8GS-21970-00	FOOTREST COMP. 2	1	1	
51	8FN-2193E-00	BRACKET, OIL TANK 1	1	1	
52	8FN-2194E-00	BRACKET, ENGINE	1	1	
53	95602-08200	NUT, SELF-LOCKING	2	2	
54	95822-10016	BOLT, FLANGE	1	1	

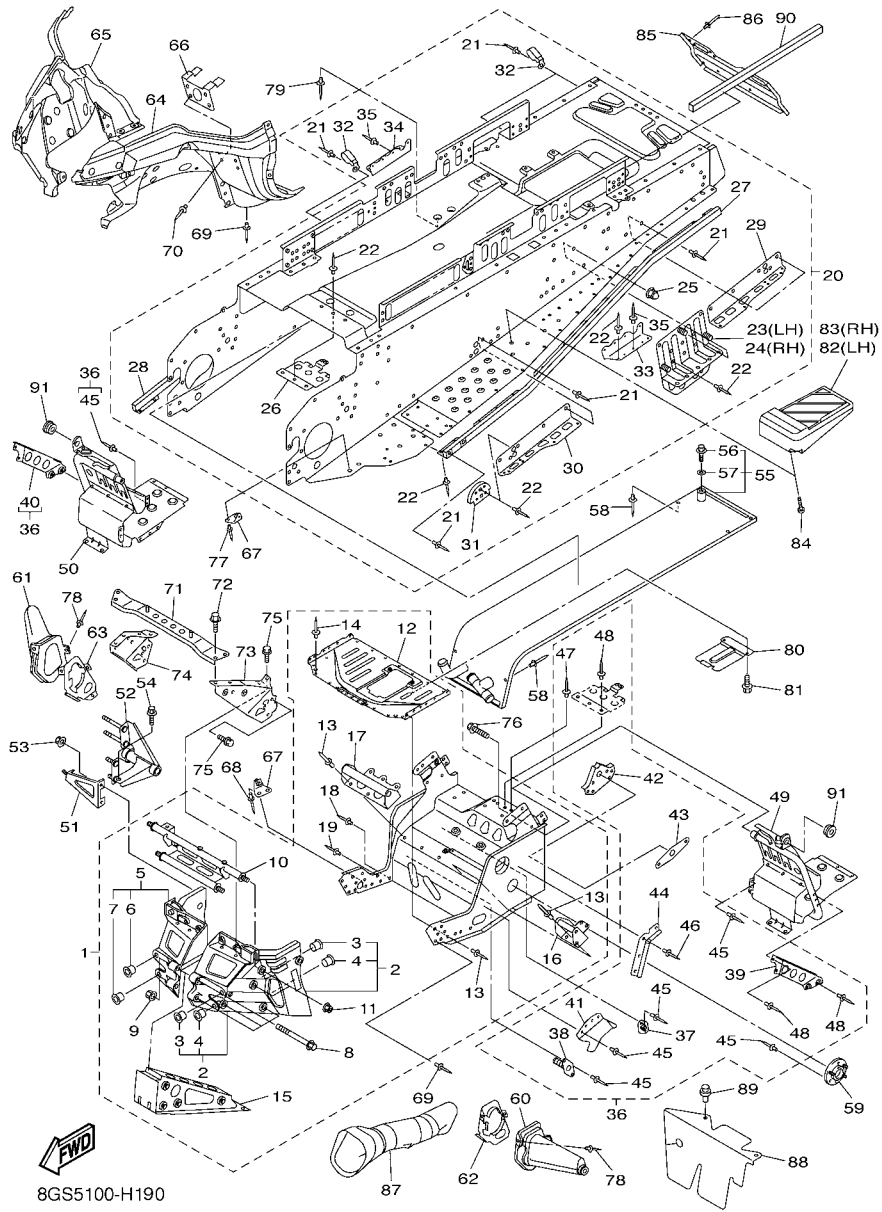

FIG. 19 FRAME

REF. NO.	PART NO.	DESCRIPTION	8GSC	8GSD	REMARKS
55	8FN-12440-00	HEAT EXCHANGER ASSY	1	1	
56	95812-06016	.BOLT, FLANGE	1	1	
57	90210-06006	.WASHER, SEAL	1	1	
58	90267-48016	RIVET, BLIND (4.8X16.4 YELLOW)	8	8	
59	8EK-21920-01	HOUSING, REINF SUB-ASSY(L.H)	1	1	
60	8FU-2198F-01	COVER 1	1	1	
61	8FU-2198J-01	COVER 3	1	1	
62	8FU-2195E-01	PLATE, STRG BRACKET 1	1	1	
63	8FU-2195F-01	PLATE, STRG BRACKET 2	1	1	
64	8ES-2196A-01	FRAME UNDER 1	1	1	
65	8FA-2196E-01	FRAME, UNDER 2	1	1	
66	8FA-21972-01	BRACKET, GUARD FITTING	1	1	
67	8FA-2196F-00	BRACKET 3	6	6	
68	90267-48083	RIVET,BLIND (4.8X15.2 SILVER)	8	8	
69	90267-48018	RIVET, BLIND (4.8X18.6 BLACK)	14	14	
70	90267-47187	RIVET, BLIND (4.7X16.4 BLACK)	4	4	
71	8FN-77512-00	BUMPER, FRONT 2	1	1	
72	95822-06012	BOLT, FLANGE	4	4	
73	8FN-21949-00	BRACKET, FRONT	1	1	
74	8FN-21959-00	BRACKET, FRONT BUMPER	1	1	
75	95822-08016	BOLT, FLANGE	6	6	
76	95822-08020	BOLT, FLANGE	2	2	
77	90267-48095	RIVET,BLIND (4.8X12.6 SILVER)	4	4	
78	90267-47195	RIVET, BLIND(4.7X16.4 YELLOW)	6	6	
79	90267-48016	RIVET, BLIND (4.8X16.4 YELLOW)	6	6	
80	8FR-2197E-00	PROTECTOR, FRAME FR	1	1	
81	92012-06012	BOLT, BUTTON HEAD	2	2	

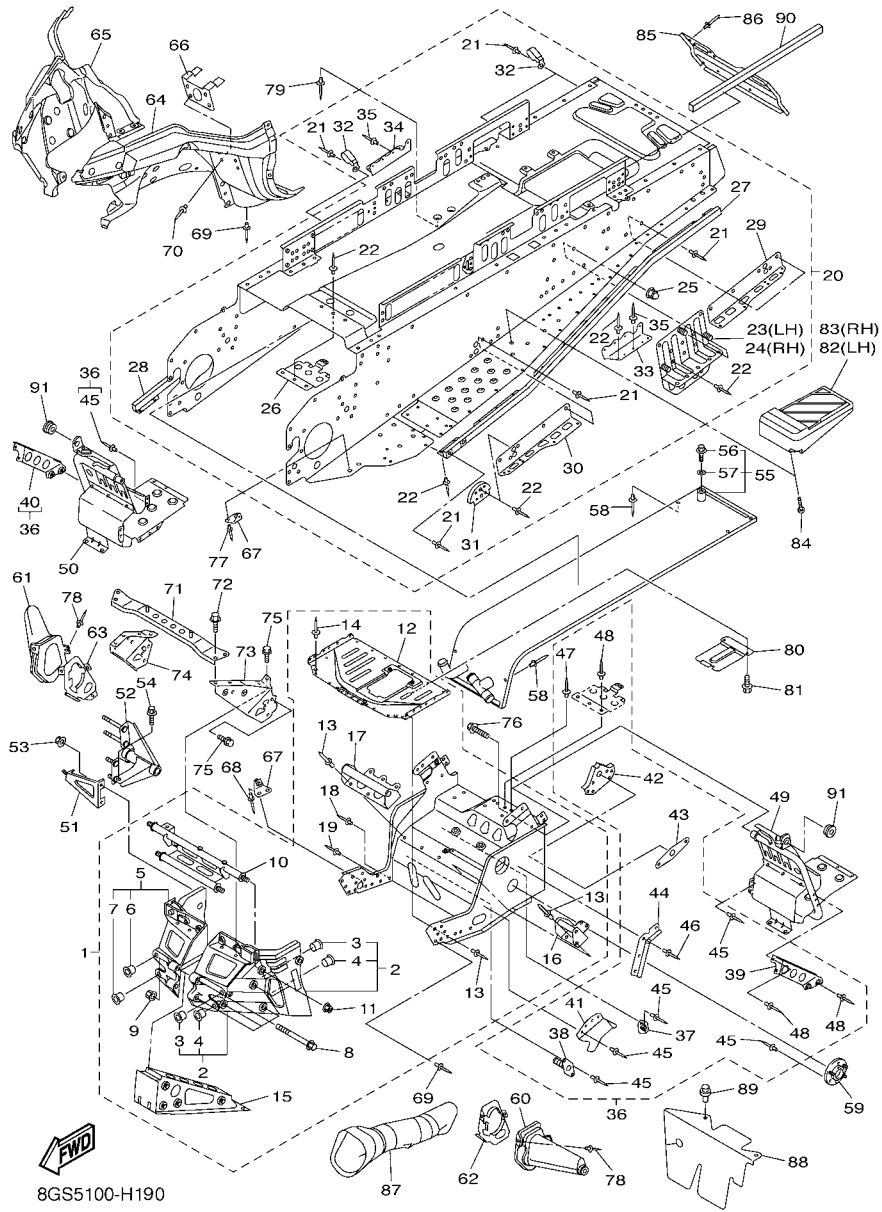
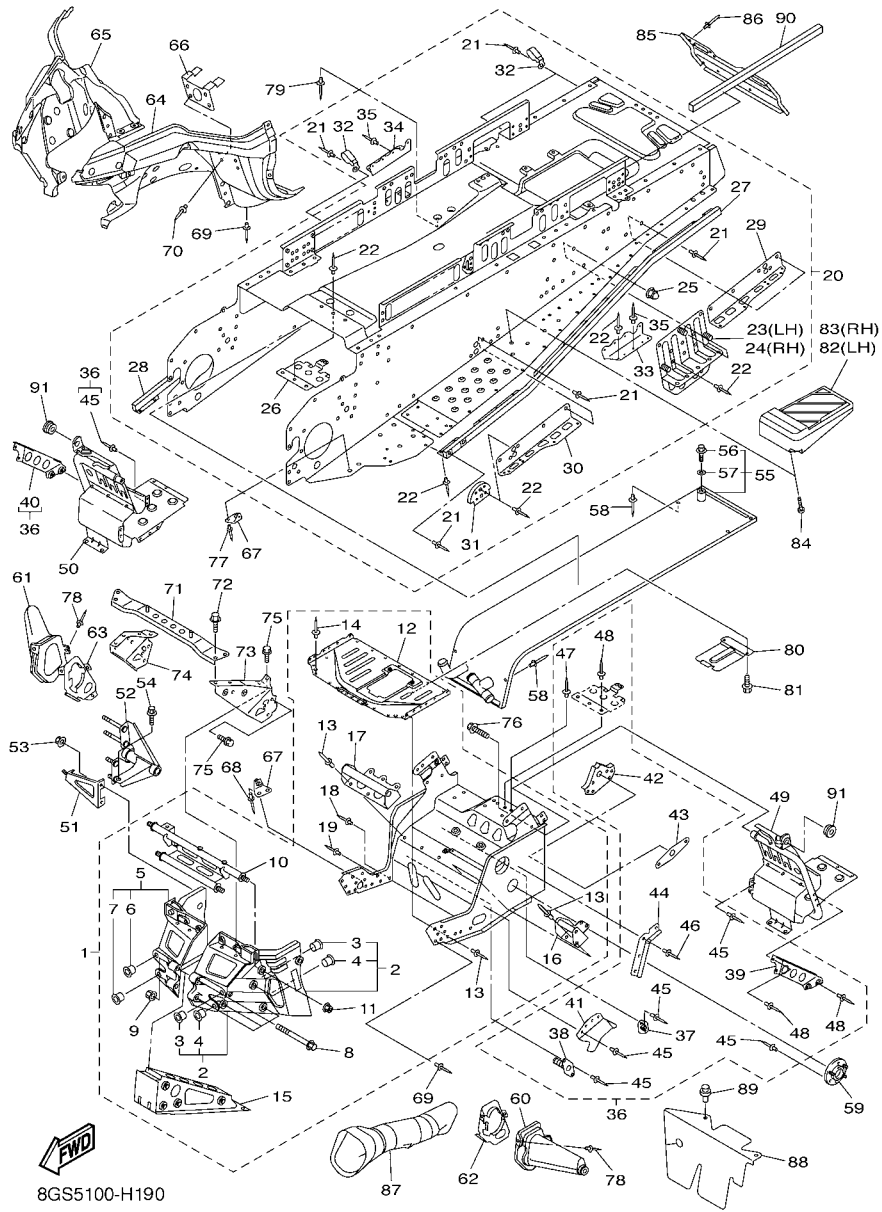
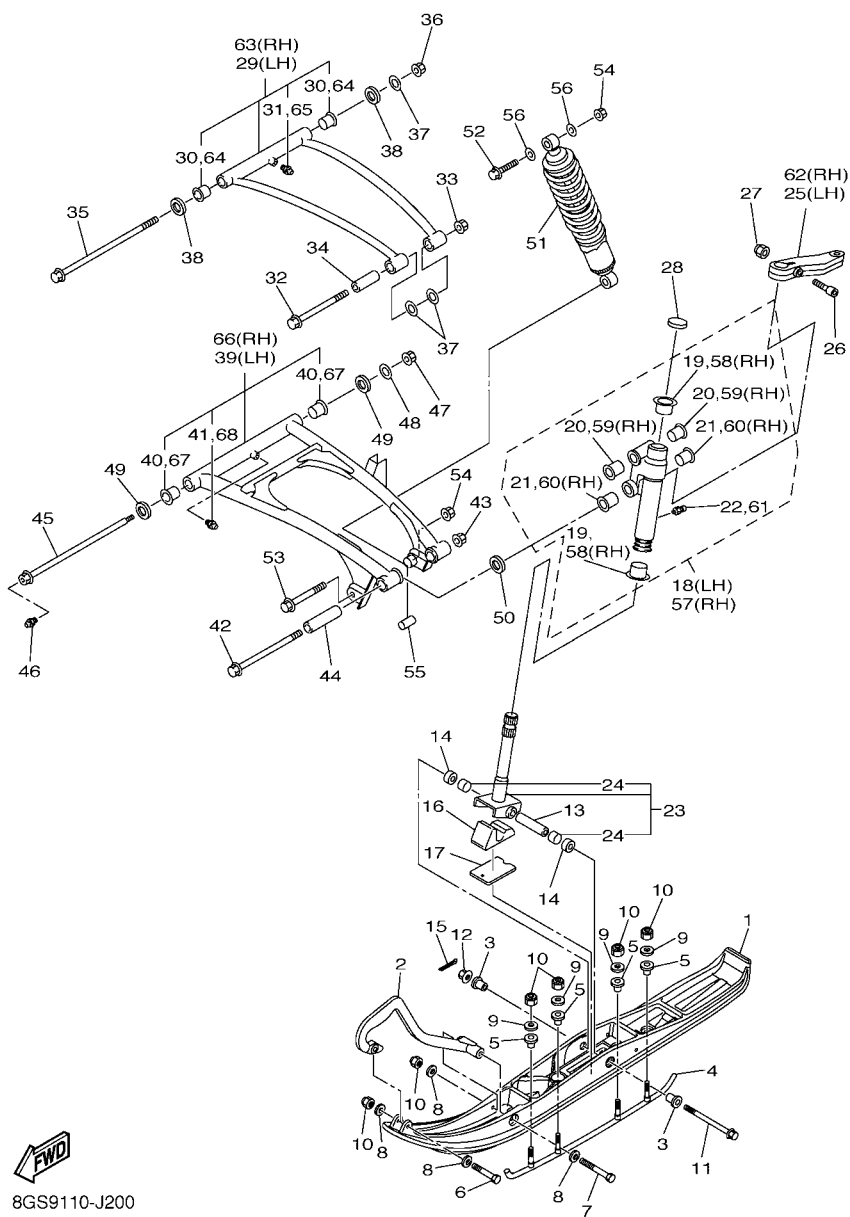

FIG. 19 FRAME

REF. NO.	PART NO.	DESCRIPTION	8GSC	8GSD	REMARKS
82	8DM-27431-02	FOOTREST, REAR 1	1	1	
83	8DM-27441-02	FOOTREST, REAR 2	1	1	
84	97702-50020	SCREW, TAPPING	8	8	
85	8FN-21933-01	REINFORCEMENT, FRAME REAR 2	1	1	
86	90267-47195	RIVET, BLIND(4.7X16.4 YELLOW)	8	8	
87	8FN-21557-00	DUCT, AIR	1	1	
88	8FN-2198F-00	COVER 1	1	1	
89	90269-09002	RIVET	2	2	
90	8FN-241A5-00	SEAL 5	1	1	
91	90480-16278	GROMMET	2	2	





8GS9110-J200

FIG. 20 SKI

REF. NO.	PART NO.	DESCRIPTION	8GSC	8GSD	REMARKS
1	8FN-F3711-00	SKI 1	2		
	8FN-23711-00	SKI 1		2	
2	8DM-F3712-00	REINFORCEMENT, HEAD	2		
	8DM-23712-00	REINFORCEMENT, HEAD		2	
3	8EX-F3754-00	COLLAR, 1	4		
	8EX-23754-00	COLLAR, 1		4	
4	8EN-F3731-01	RUNNER 1	2		
	8EN-23731-01	RUNNER 1		2	
5	8EK-F3751-00	BUSH, SKI 1	8		
	8EK-23751-00	BUSH, SKI 1		8	
6	8HG-F3755-00	BOLT, REINFORCEMENT HEAD 1	2		
	8HG-23755-00	BOLT, REINFORCEMENT HEAD 1		2	
7	8HG-F3756-00	BOLT, REINFORCEMENT HEAD 2	2		
	8HG-23756-00	BOLT, REINFORCEMENT HEAD 2		2	
8	8HG-F3737-00	WASHER 1	8		
	8HG-23737-00	WASHER 1		8	
9	8HG-F3738-00	WASHER 2	8		
	8HG-23738-00	WASHER 2		8	
10	8HG-F3778-00	NUT	12		
	8HG-23778-00	NUT		12	
11	90105-10106	BOLT, FLANGE	2	2	
12	95607-10200	NUT, U FLANGE	2	2	
13	90387-1012H	COLLAR	2	2	
14	90387-10029	COLLAR	4	4	
15	91401-20020	PIN, COTTER	2	2	
16	8ES-23743-00	STOPPER 1	2	2	
17	8FM-23744-00	STOPPER 2	2	2	

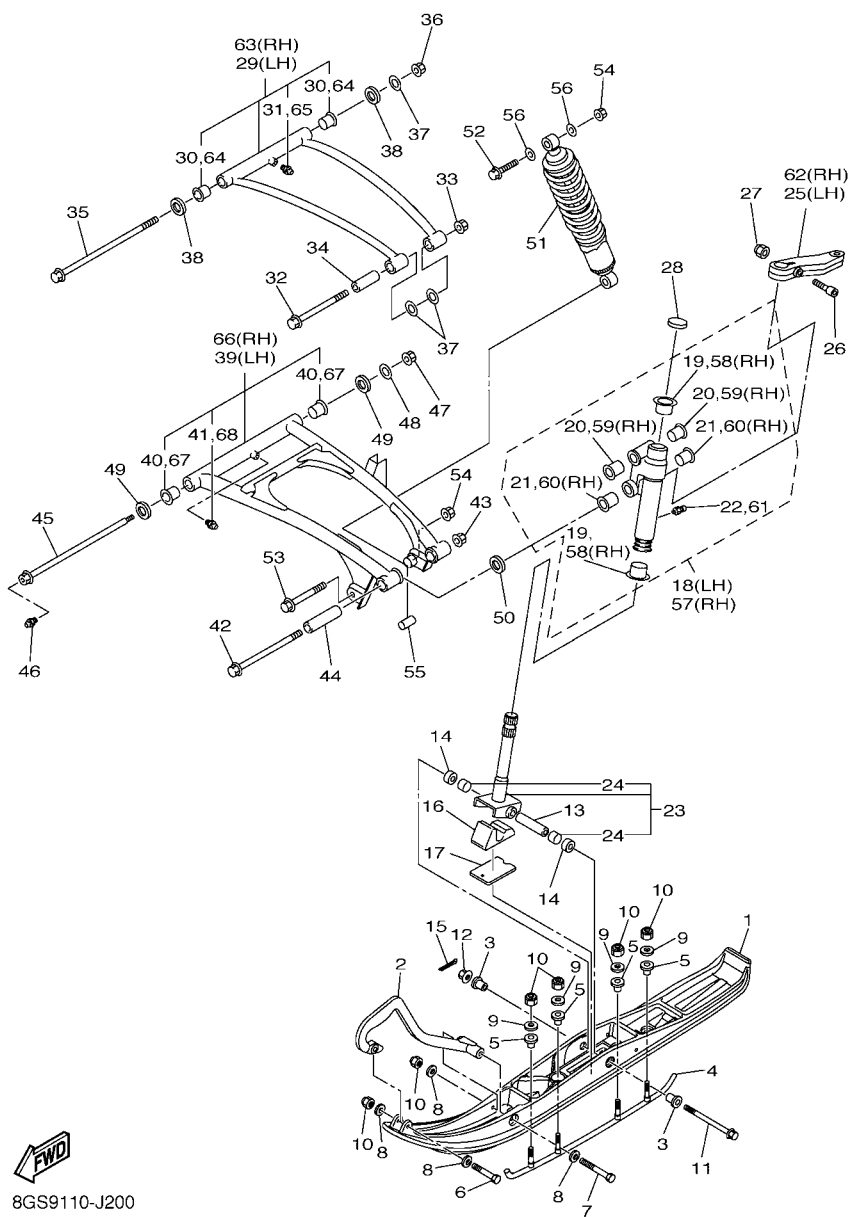

8GS9110-J200

FIG. 20 SKI

REF. NO.	PART NO.	DESCRIPTION	8GSC	8GSD	REMARKS
18	8ES-23501-00	STEERING KNUCKLE ASSY (LEFT)	1	1	
19	90381-25115	.BUSH, SOLID	2	2	
20	90381-15N50	.BUSH, SOLID	2	2	
21	90381-18N51	.BUSH, SOLID	2	2	
22	93700-06004	.NIPPLE, GREASE	1	1	
23	8ES-23803-00	COLUMN, SKI ASSY	2	2	
24	90384-16N51	.BUSH, BIMETAL FORMED	2	2	
25	8FN-23851-00	ARM, OUTSIDE 1	1	1	
26	90110-08N53	BOLT, HEXAGON SOCKET HEAD	2	2	
27	95607-08200	NUT, SELF-LOCKING	2	2	
28	3YK-22472-40	CAP, CASE	2	2	
29	8GS-23540-00	FRONT UPPER ARM COMP. (LEFT)	1	1	
30	90381-15N50	.BUSH, SOLID	2	2	
31	93700-06004	.NIPPLE, GREASE	1	1	
32	90105-10N51	BOLT, FLANGE	2	2	
33	95607-10200	NUT, U FLANGE	2	2	
34	90387-10N58	COLLAR	2	2	
35	90105-10N54	BOLT, FLANGE	2	2	
36	95607-10200	NUT, U FLANGE	2	2	
37	90201-106F2	WASHER, PLATE	6	6	
38	90209-15N50	WASHER	4	4	
39	8GS-23570-00	FRONT LOWER ARM COMP. (LEFT)	1	1	
40	90381-16N51	.BUSH, SOLID	2	2	
41	93700-06004	.NIPPLE, GREASE	1	1	
42	90105-12N54	BOLT, FLANGE	2	2	
43	95607-12200	NUT, SELF-LOCKING	2	2	
44	90387-12N54	COLLAR	2	2	

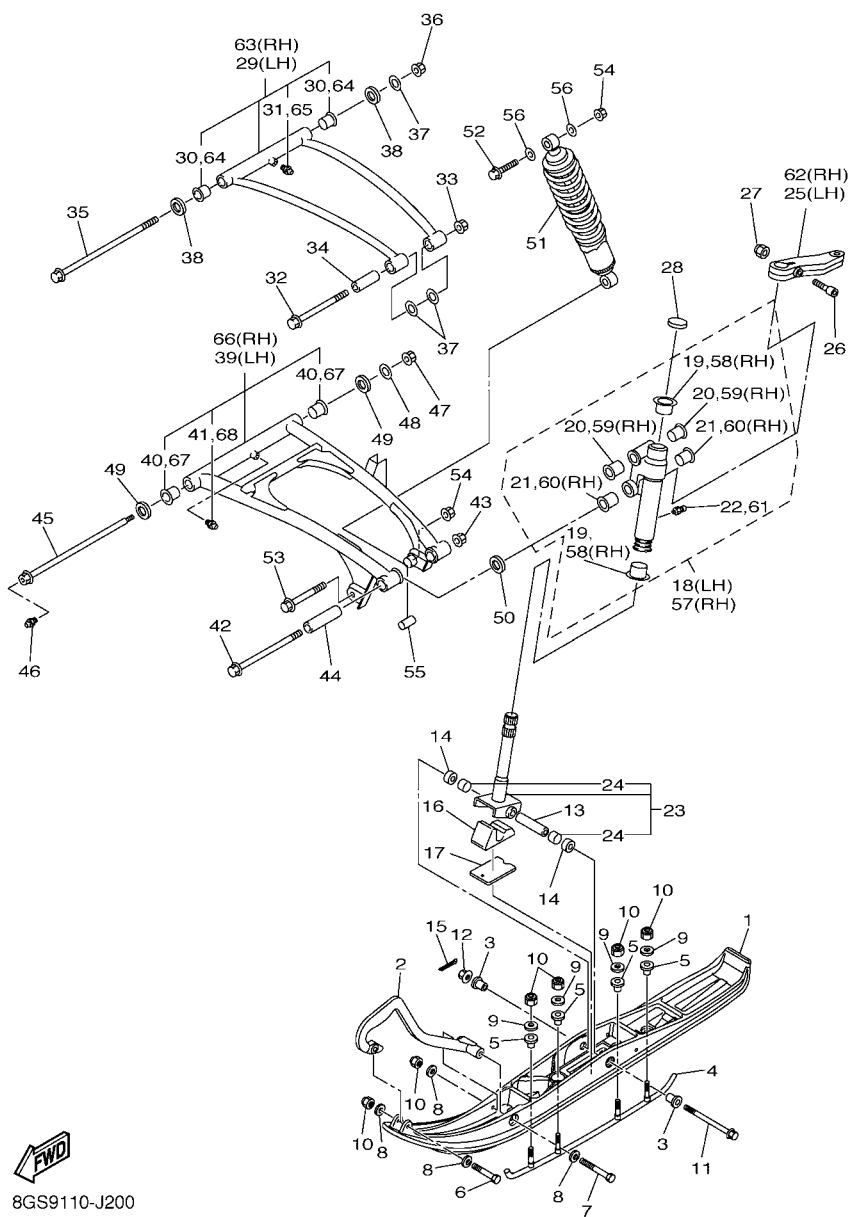

8GS9110-J200

FIG. 20 SKI

REF. NO.	PART NO.	DESCRIPTION	8GSC	8GSD	REMARKS
45	90401-10043	BOLT, UNION	2	2	
46	93700-06004	NIPPLE, GREASE	2	2	
47	95607-10200	NUT, U FLANGE	2	2	
48	90201-106F2	WASHER, PLATE	2	2	
49	90209-15N50	WASHER	4	4	
50	90201-12032	WASHER, PLATE	4	4	
51	8FN-2376A-00	ABSORBER ASSY 1	2	2	
52	90105-10232	BOLT, FLANGE	2	2	
53	90105-10392	BOLT, FLANGE	2	2	
54	95607-10200	NUT, U FLANGE	4	4	
55	90387-10N59	COLLAR	2	2	
56	90201-106F2	WASHER, PLATE	4	4	
57	8ES-23502-00	STEERING KNUCKLE ASSY (RIGHT)	1	1	
58	90381-25115	.BUSH, SOLID	2	2	
59	90381-15N50	.BUSH, SOLID	2	2	
60	90381-18N51	.BUSH, SOLID	2	2	
61	93700-06004	.NIPPLE, GREASE	1	1	
62	8FN-23852-00	ARM, OUTSIDE 2	1	1	
63	8GS-23550-00	FRONT UPPER ARM COMP. (RIGHT)	1	1	
64	90381-15N50	.BUSH, SOLID	2	2	
65	93700-06004	.NIPPLE, GREASE	1	1	
66	8GS-23580-00	FRONT LOWER ARM COMP. (RIGHT)	1	1	
67	90381-16N51	.BUSH, SOLID	2	2	
68	93700-06004	.NIPPLE, GREASE	1	1	

FIG. 21 STEERING

REF. NO.	PART NO.	DESCRIPTION	8GSC	8GSD	REMARKS
1	8FN-26110-00	HANDLE COMP.	1	1	
2	8FS-23829-00	.STRAP, STRG	1	1	
3	92014-06020	.BOLT, BUTTON HEAD	2	2	
4	8FA-23813-01	COLUMN, STEERING 2	1	1	
5	8K1-23814-00	HOLDER, HANDLE	2	2	
6	8ED-23442-00	HOLDER, HANDLE LOWER	1	1	
7	8DF-23857-00	HOLDER	1	1	
8	8FK-2381B-00	JOINT	1	1	
9	90105-08072	BOLT, FLANGE	4	4	
10	90201-08020	WASHER, PLATE	2	2	
11	8FA-23811-00	COLUMN, STEERING	1	1	
12	8FA-23818-02	COVER, STEERING	1	1	
13	8FA-23873-01	BEARING, STEERING UPPER	1	1	
14	8FN-23867-00	HOLDER 2	1	1	
15	90105-10549	BOLT, FLANGE	1	1	
16	95602-10200	NUT, U FLANGE	1	1	
17	90105-08552	BOLT, FLANGE	2	2	
18	95602-08200	NUT, SELF-LOCKING	2	2	
19	90468-12006	CLIP	3	3	
20	8FA-23872-00	HOLDER, BEARING	1	1	
21	8FN-2376H-00	HOLDER, BEARING	1	1	
22	8FA-23812-00	BEARING, STEERING	6	6	
23	8FA-23867-00	HOLDER 2	2	2	
24	8FN-23872-00	HOLDER, BEARING	1	1	
25	95312-08600	NUT	6	6	
26	1UY-23894-01	WASHER, LOCK 1	3	3	
27	8HF-2412G-00	COLLAR	6	6	

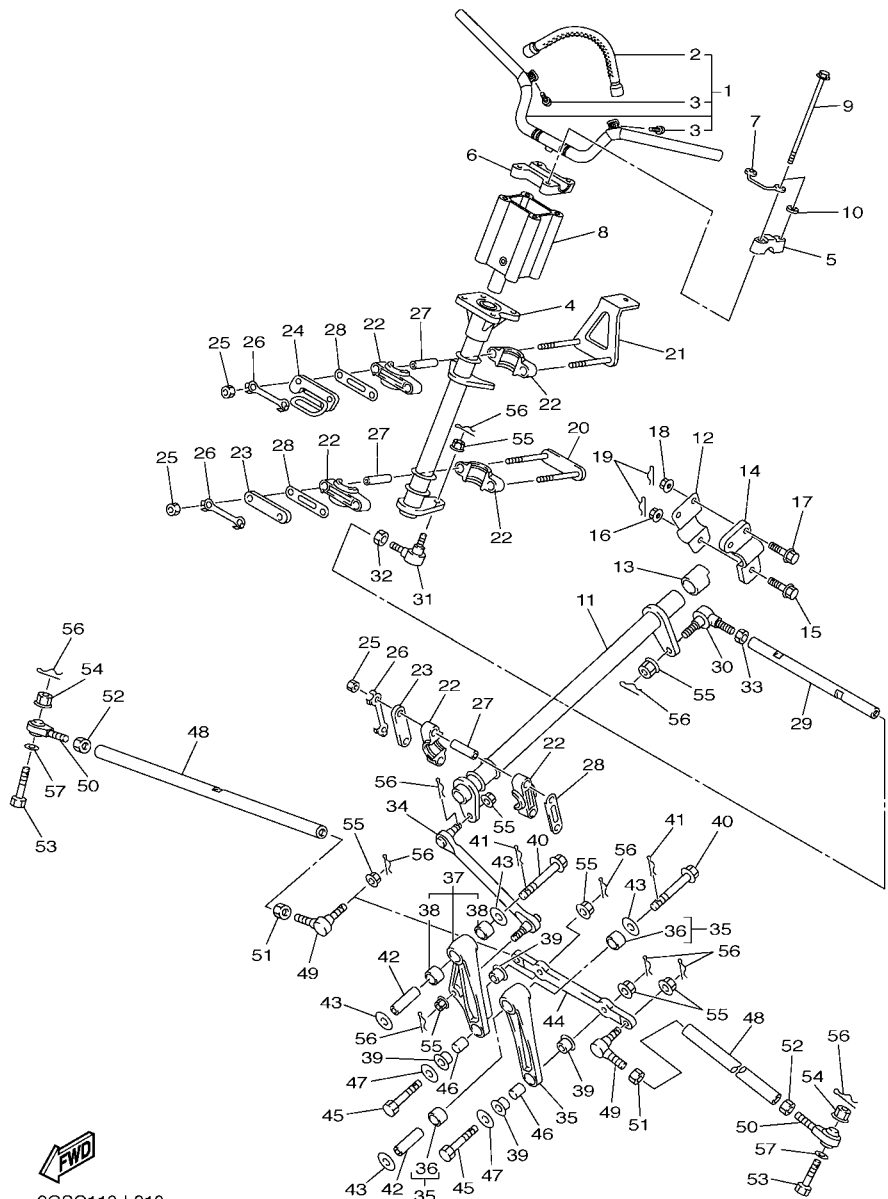

8GSC110-L210

FIG. 21 STEERING

REF. NO.	PART NO.	DESCRIPTION	8GSC	8GSD	REMARKS
28	8FA-23843-00	WASHER, PLAIN	3	3	
29	8FN-23828-00	ROD, STEERING	1	1	
30	8CR-23847-00	JOINT, UNIVERSAL 3	1	1	
31	8CR-23845-10	JOINT, UNIVERSAL 2	1	1	
32	95307-10700	NUT	1	1	
33	90170-10186	NUT	1	1	(L.H. THREAD)
34	8FA-23821-00	ROD, STEERING RELAY	1	1	
35	8FN-2389K-00	ARM PIVOT ASSY	1	1	
36	90383-17001	.BUSH, FORMED	2	2	
37	8FN-2389M-00	PIVOT ARM ASSY 2	1	1	
38	93317-41785	.BEARING	2	2	
39	90381-14001	BUSH, SOLID	4	4	
40	90105-12017	BOLT, FLANGE	2	2	
41	8FA-2384N-00	CLIP, RING	2	2	
42	8FA-2412G-00	COLLAR	2	2	
43	90201-121U3	WASHER, PLATE	4	4	
44	8FN-23826-00	ARM, IDLER	1	1	
45	90102-10044	BOLT, WITH HOLE	2	2	
46	90387-10008	COLLAR	2	2	
47	90201-10742	WASHER, PLATE	2	2	
48	8FN-23831-00	ROD, TIE	2	2	
49	8CR-23845-10	JOINT, UNIVERSAL 2	2	2	
50	8FA-23847-00	JOINT, UNIVERSAL 3	2	2	
51	95307-10700	NUT	2	2	
52	90170-10186	NUT	2	2	(L.H. THREAD)
53	90102-10044	BOLT, WITH HOLE	2	2	
54	95702-10300	NUT, NYLON	2	2	

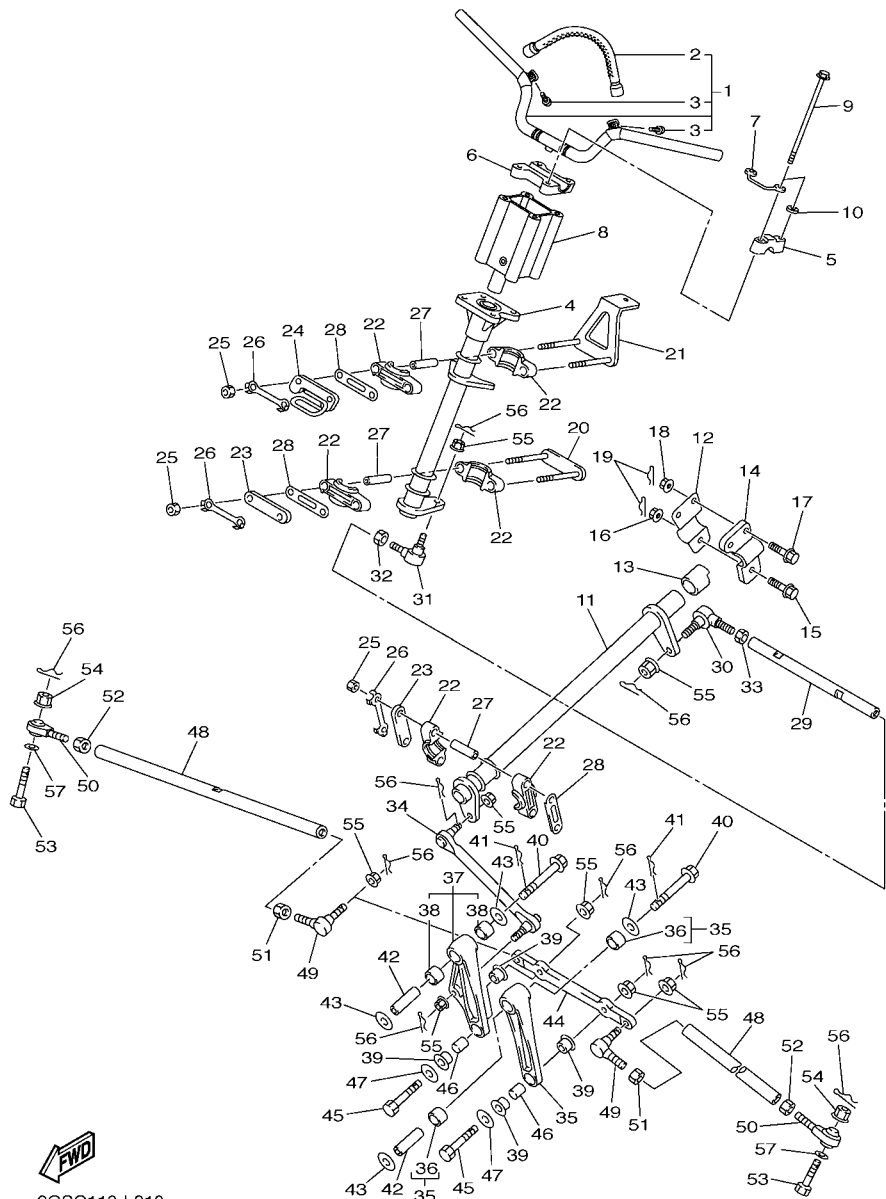

8GSC110-L210

FIG. 21 STEERING

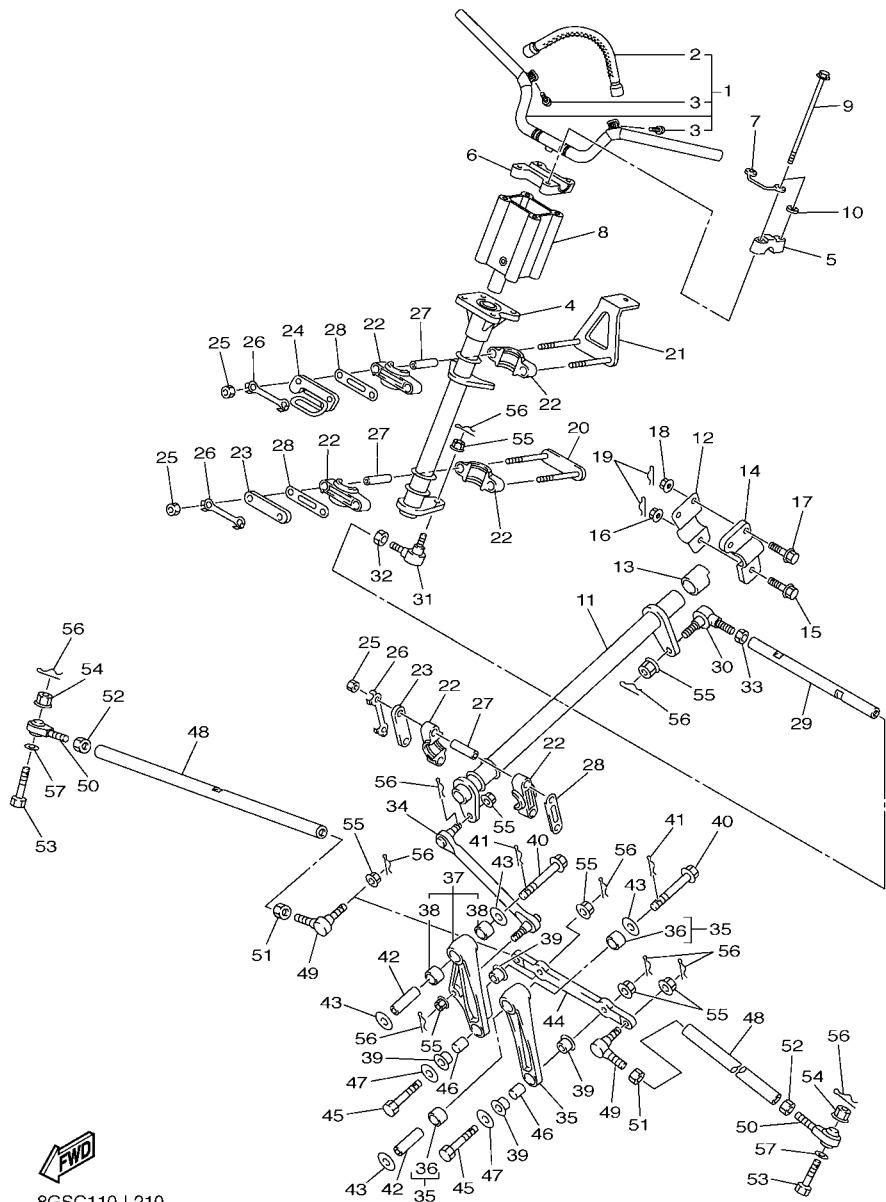

8GSC110-L210

REF. NO.	PART NO.	DESCRIPTION	8GSC	8GSD		REMARKS
55	95702-10500	NUT, FLANGE	8	8		
56	91402-20020	PIN, COTTER	10	10		
57	90201-08759	WASHER, PLATE	2	2		

FIG. 22 STEERING GATE

REF. NO.	PART NO.	DESCRIPTION	8GSC	8GSD	REMARKS
1	8GS-23870-00	STEERING GATE COMP.	1	1	
2	90464-11007	.CLAMP	2	2	
3	8FN-24181-00	DAMPER, LOCATING 1	2	2	
4	8FN-24182-00	DAMPER, LOCATING 2	1	1	
5	8FA-2389C-E0	LABEL, CAUTION	1		
	8FA-2389C-S0	LABEL, CAUTION		1	UR FOR EUR,RUS
	8FA-2389C-J0	LABEL, CAUTION		1	UR FOR JPN
6	90105-081A7	BOLT, FLANGE	2	2	
7	90201-08326	WASHER, PLATE	4	4	
8	95822-08020	BOLT, FLANGE	7	7	
9	8FA-2389E-00	LATCH	1	1	
10	95602-08200	NUT, SELF-LOCKING	9	9	
11	90462-10022	CLAMP	2	2	
12	8FN-23815-00	PAD, STEERING	1	1	
13	8ES-14146-00	PLATE	1	1	AP
14	90150-06015	SCREW, ROUND HEAD	1	1	AP

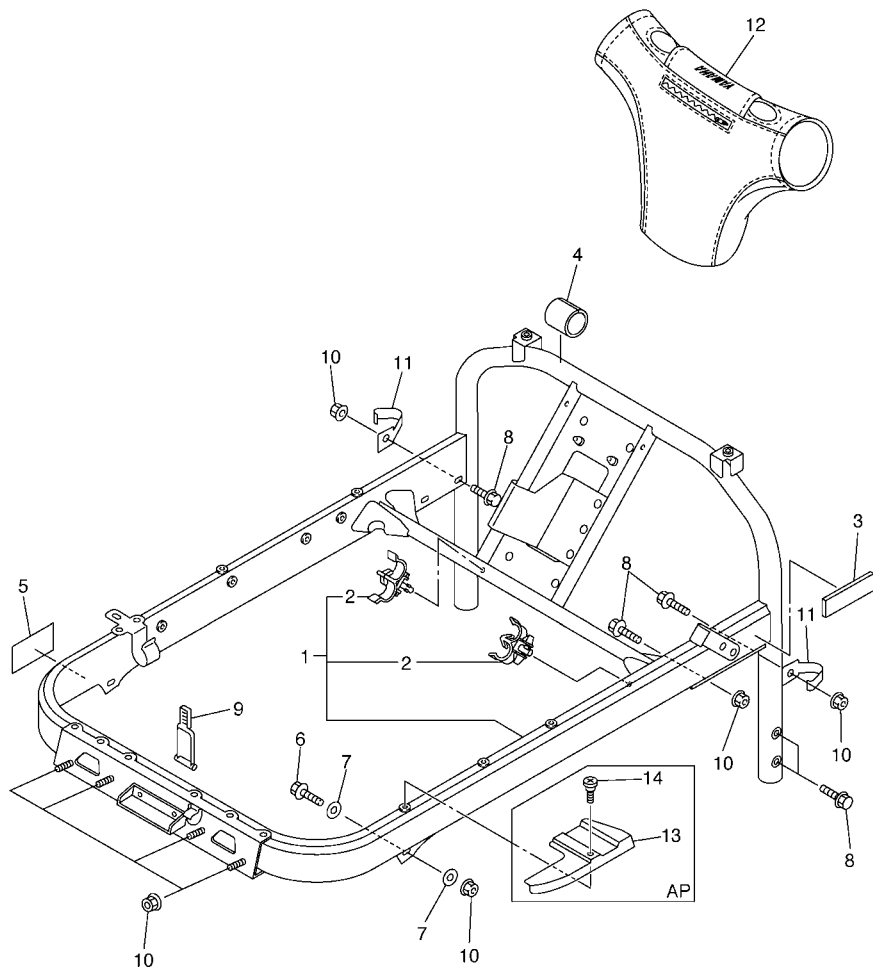

8FN1100-E220

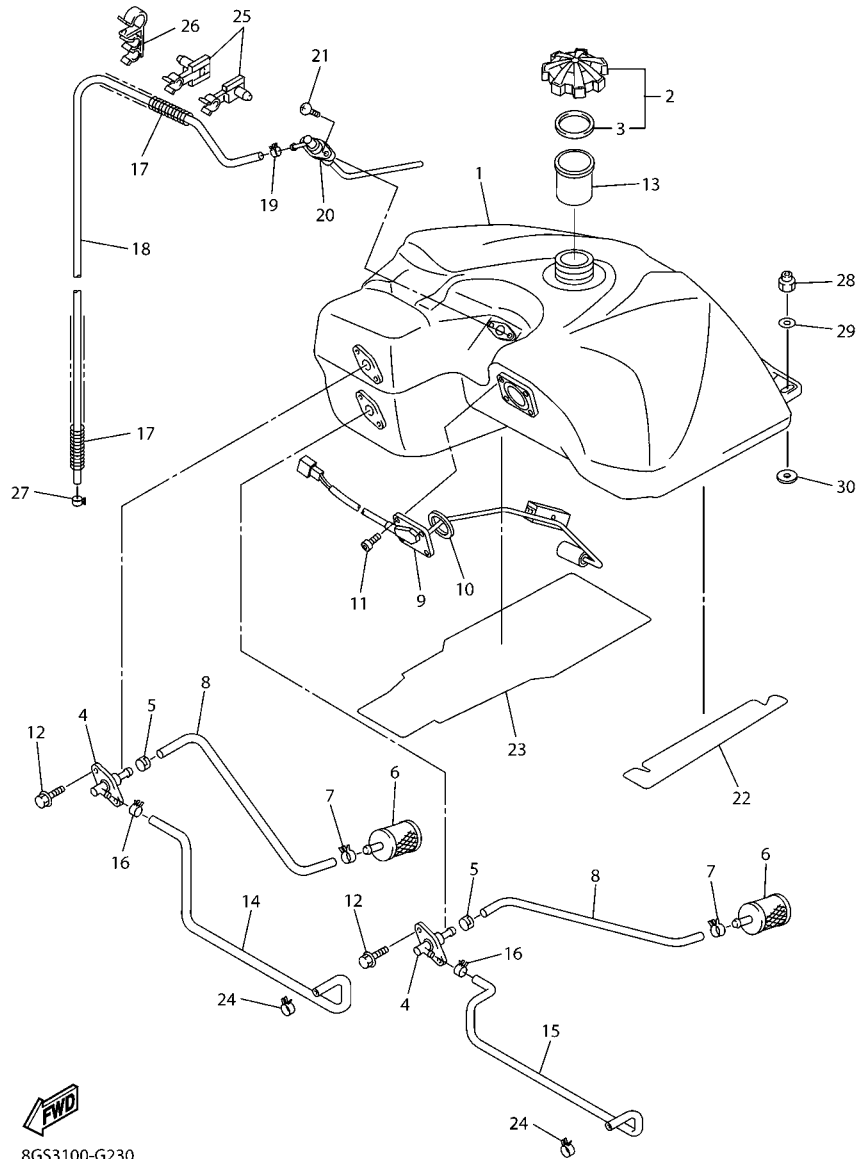

8GS3100-G230

FIG. 23 FUEL TANK

REF. NO.	PART NO.	DESCRIPTION	8GSC	8GSD	REMARKS
1	8FN-24111-10	TANK, FUEL	1		
	8FN-24111-01	TANK, FUEL		1	
2	8FG-24610-00	CAP ASSY	1	1	
3	8FG-24641-00	.GASKET, CAP 1	1	1	
4	8CR-24301-00	SUCTION PIPE COMP. 1	2	2	
5	90468-04092	CLIP	2	2	
6	8H5-24560-00	FILTER ASSY	2	2	
7	90467-11032	CLIP	2	2	
8	8FA-24335-00	PIPE, SUCTION 1	2	2	
9	8GS-85752-00	SENDER UNIT ASSY, FUEL METER	1	1	
10	93210-41041	O-RING	1	1	
11	98902-05008	SCREW, BIND	4	4	
12	90105-060A6	BOLT, FLANGE	4	4	
13	8FN-24114-00	TUBE, FILLER	1	1	
14	8GS-24311-00	PIPE, FUEL 1	1		
	8FN-24311-00	PIPE, FUEL 1		1	
15	8GS-24311-10	PIPE, FUEL 1	1		
	8FN-24311-10	PIPE, FUEL 1		1	
16	90467-11032	CLIP	2	2	
17	90501-08668	SPRING, COMPRESSION	2	2	
18	91A20-05130	TUBE, FLEXIBLE VINYL	1	1	
19	90467-09026	CLIP	1	1	
20	8FN-2418A-00	BREATHER COMP.	1	1	
21	90149-06330	SCREW	2	2	
22	8GS-24181-00	DAMPER, LOCATING 1	1		
23	8GS-24182-00	DAMPER, LOCATING 2	1		
24	90467-11032	CLIP	2	2	

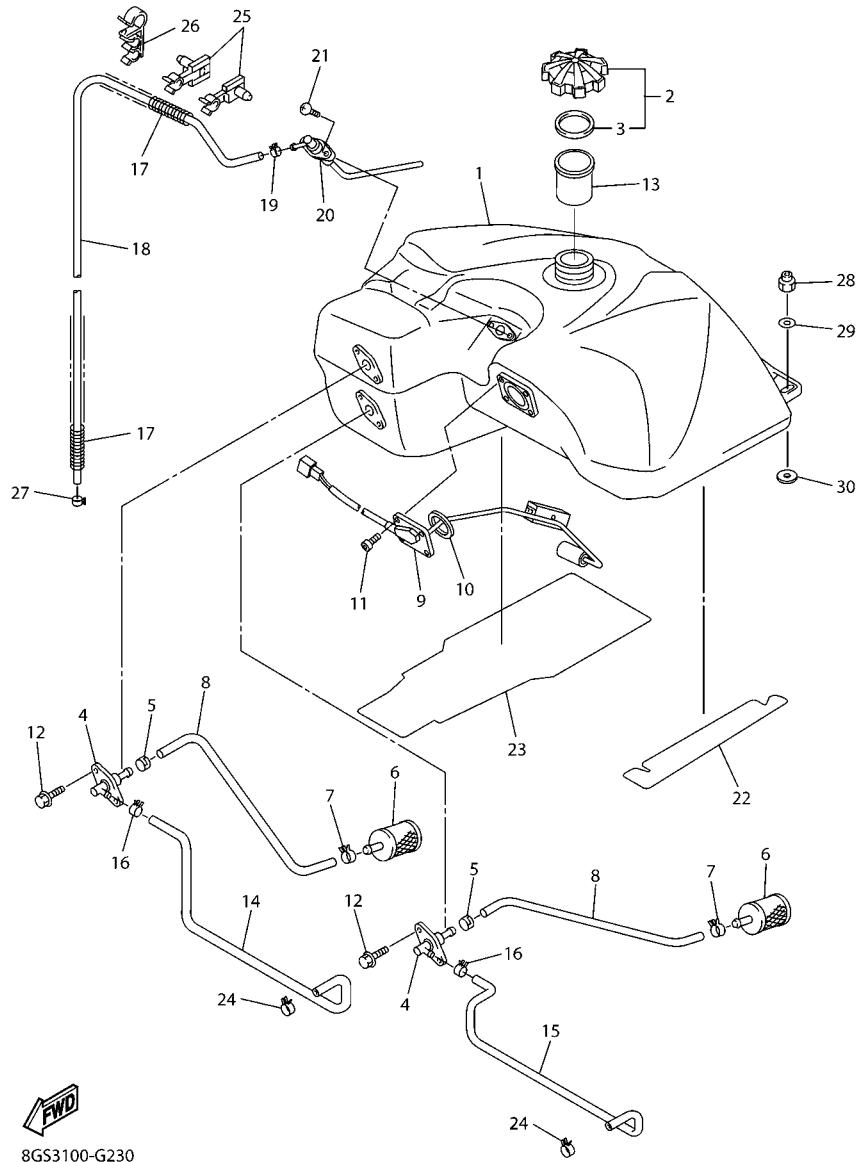

8GS3100-G230

FIG. 23 FUEL TANK

REF. NO.	PART NO.	DESCRIPTION	8GSC	8GSD		REMARKS
25	90464-09015	CLAMP	2	2		
26	90464-16010	CLAMP	1	1		
27	90467-09026	CLIP	1	1		
28	95702-08300	NUT, NYLON	2	2		
29	90201-08053	WASHER, PLATE	2	2		
30	90201-08075	WASHER, PLATE	2			
<hr style="border-top: 1px dashed black;"/>						
<hr style="border-top: 1px dashed black;"/>						
<hr style="border-top: 1px dashed black;"/>						
<hr style="border-top: 1px dashed black;"/>						
<hr style="border-top: 1px dashed black;"/>						
<hr style="border-top: 1px dashed black;"/>						
<hr style="border-top: 1px dashed black;"/>						

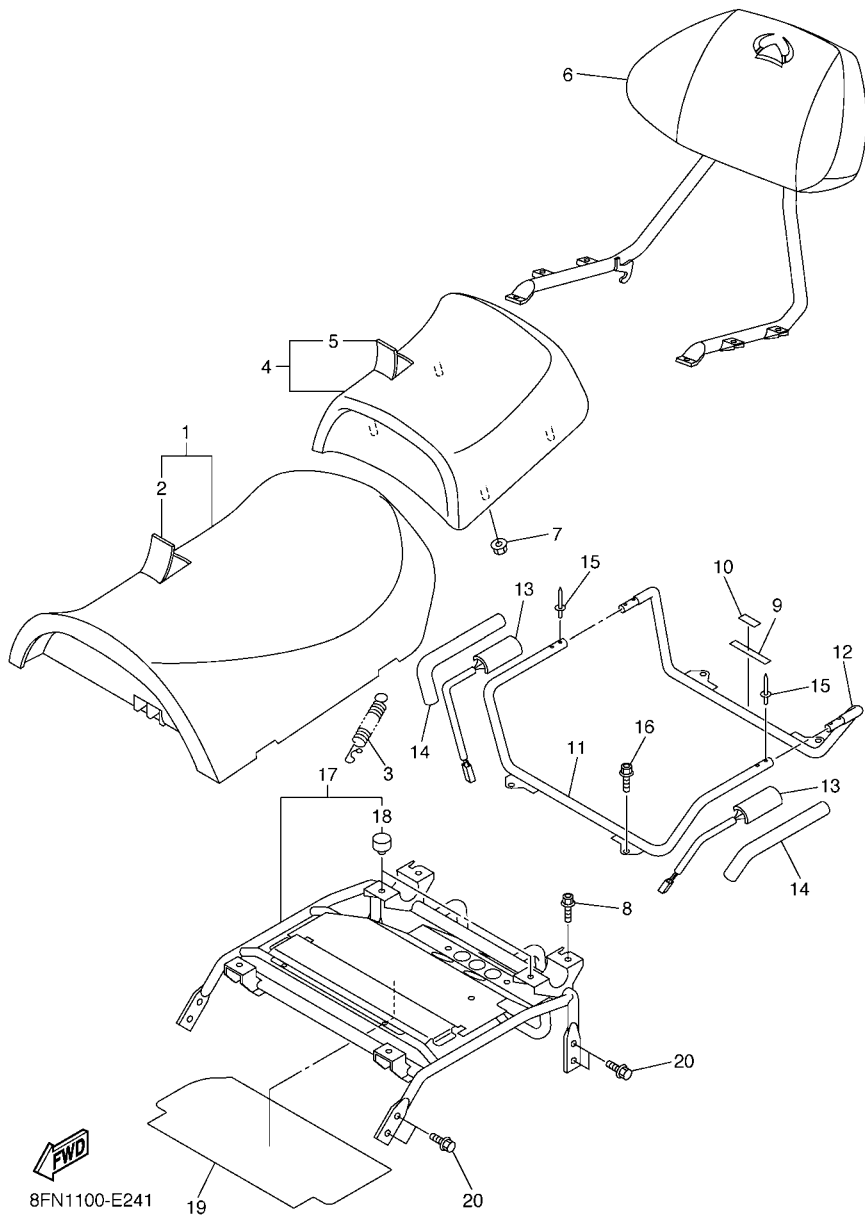
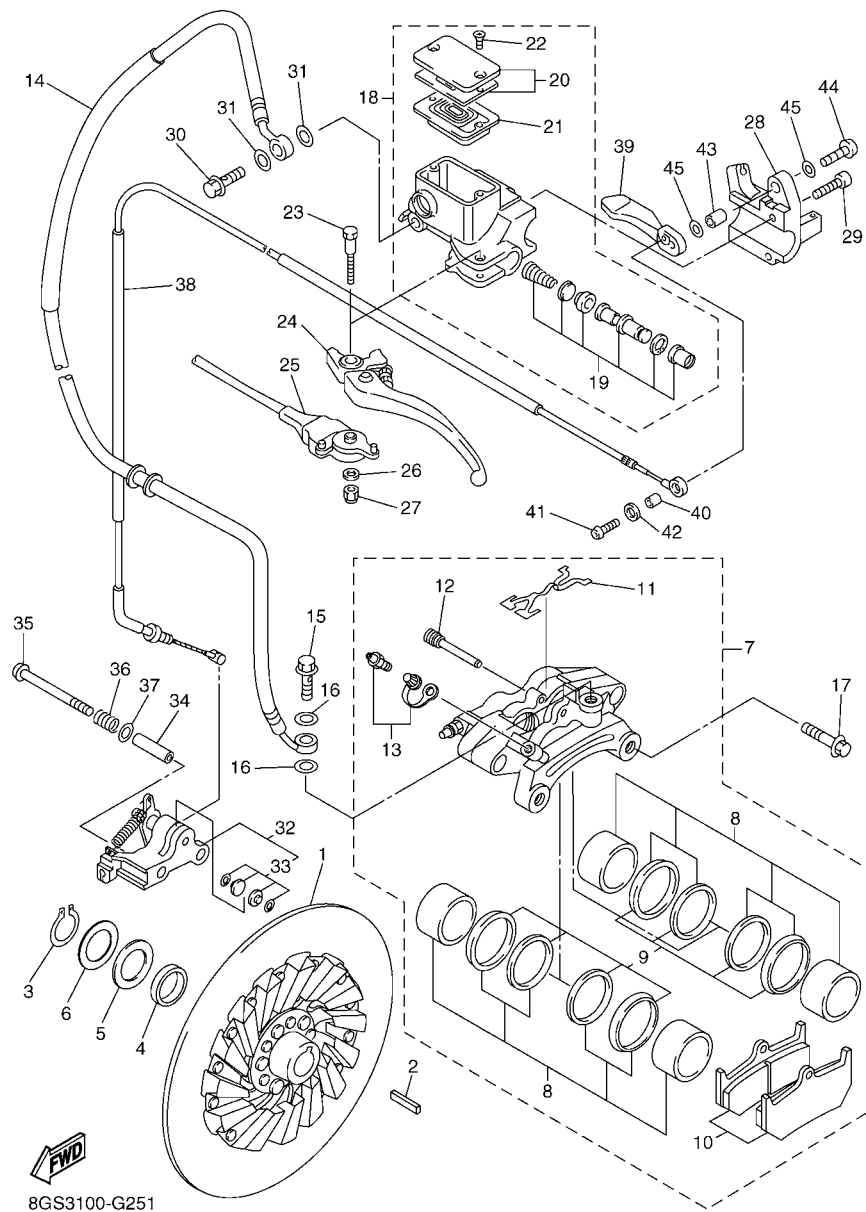

FIG. 24 SEAT

REF. NO.	PART NO.	DESCRIPTION	8GSC	8GSD	REMARKS
1	8FN-24710-02	SINGLE SEAT ASSY	1	1	
2	8FN-2470F-02	.SEAT COVER COMP.	1	1	
3	89A-77159-00	CLAMP, ROD	1	1	
4	8FN-24750-01	TANDEM SEAT ASSY	1	1	
5	8FN-2470H-01	.SEAT COVER COMP. ,2	1	1	
6	8FN-24790-00	SEAT BACK ASSY	1	1	
7	95702-06500	NUT, FLANGE	4	4	
8	90105-10151	BOLT, FLANGE	2	2	
9	8FN-24897-00	EMBLEM	1		
	8FN-24897-10	EMBLEM		1	
10	3AC-24877-C0	LABEL, CAUTION	1		FOR JPN
11	8FN-2474A-00	ASSIST, GRIP	1	1	
12	8FN-2474W-00	ASSIST,GRIP 2	1	1	
13	8GS-2474B-00	ASSIST GRIP WARMER ASSY 1	2	2	
14	8ET-24796-00	COVER	2	2	
15	90267-47186	RIVET, BLIND (4.7X16.4 BLACK)	6	6	
16	90105-10151	BOLT, FLANGE	2	2	
17	8FN-2474H-00	BRACKET, ASSIST GRIP 1	1	1	
18	8FA-27114-00	.STOPPER	2	2	
19	8FN-2476U-00	PROTECTOR,1	1	1	
20	95822-08014	BOLT, FLANGE	8	8	



8GS3100-G251

FIG. 25 BRAKE

REF. NO.	PART NO.	DESCRIPTION	8GSC	8GSD	REMARKS
1	8FU-2581T-00	DISK BRAKE ASSY	1	1	
2	90282-07002	KEY, STRAIGHT	1	1	
3	99009-24400	CIRCLIP	1	1	
4	90387-25011	COLLAR	1	1	
5	90201-25527	WASHER, PLATE (T1.0)	2	2	UN
6	90201-252F1	WASHER, PLATE (T0.5)	2	2	UN
7	8FU-2580T-01	CALIPER ASSY (LEFT)	1	1	
8	8FU-W0057-00	.PISTON ASSY, CALIPER	2	2	
9	3JD-W0047-10	..CALIPER SEAL KIT	1	1	
10	8FU-W0046-01	.BRAKE PAD KIT 2	1	1	
11	8FU-25919-00	.SUPPORT, PAD	1	1	
12	8FU-25924-00	.PIN, PAD	1	1	
13	8CR-W0048-00	.BLEED SCREW KIT	2	2	
14	8GS-25872-01	HOSE, BRAKE 1	1	1	
15	90401-10015	BOLT, UNION	1	1	
16	90201-10118	WASHER, PLATE	2	2	
17	90105-10096	BOLT, FLANGE	2	2	
18	8EN-W2587-00	MASTER CYLINDER SUB ASSY	1	1	UR FOR EUR,RUS
	8EN-W2587-10	MASTER CYLINDER SUB ASSY	1	1	UR FOR JPN
19	8CR-W0041-00	.CYLINDER KIT, MASTER	1	1	
20	8CR-W2585-00	.RESERVOIR CAP SET	1	1	UR FOR EUR,RUS
	3GM-W2585-21	.RESERVOIR CAP SET	1	1	UR FOR JPN
21	55U-25854-00	.DIAPHRAGM, RESERVOIR	1	1	
22	98706-04012	.SCREW, FLAT HEAD	2	2	
23	8CR-2589F-00	BOLT, LEVER	1	1	
24	8CR-83912-00	LEVER 1	1	1	
	8DN-83912-00	LEVER 1	1	1	AP

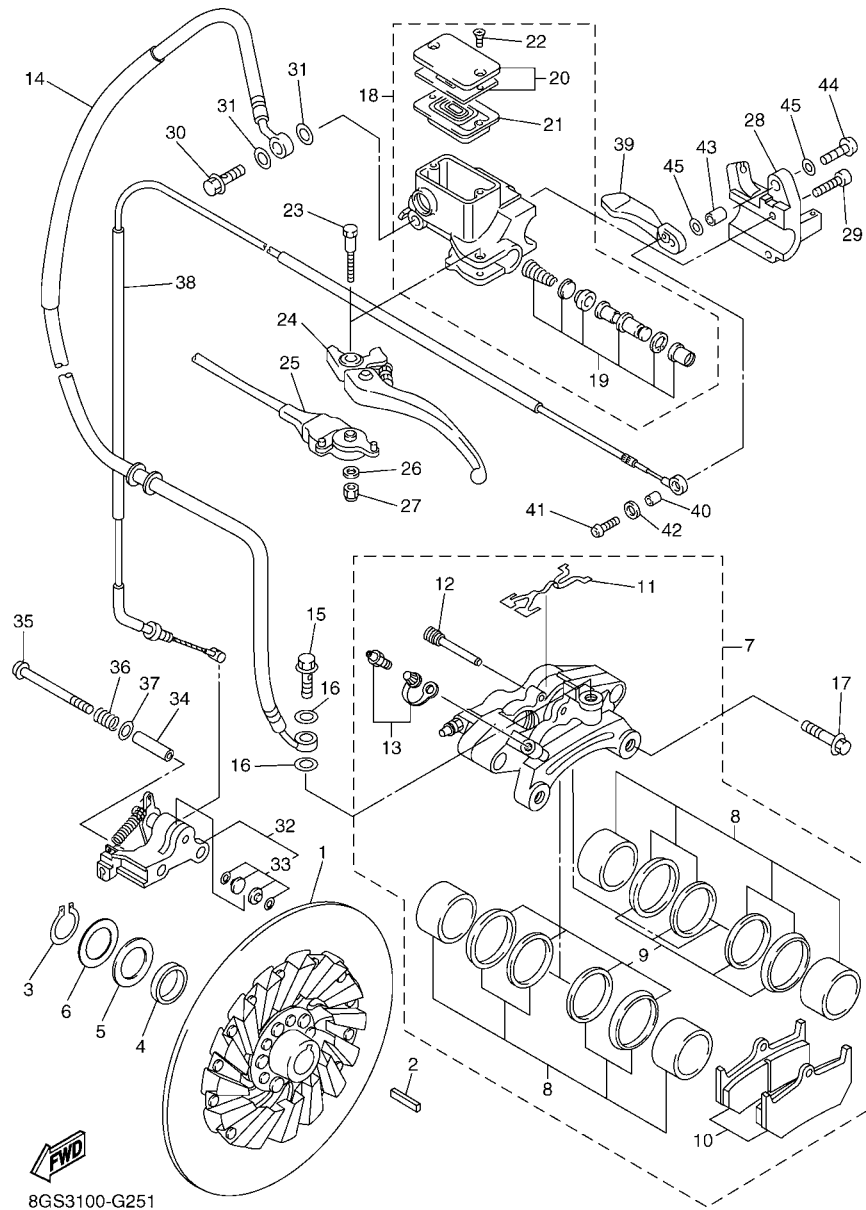

8GS3100-G251

FIG. 25 BRAKE

REF. NO.	PART NO.	DESCRIPTION	8GSC	8GSD	REMARKS
25	8CR-82530-01	STOP SWITCH ASSY	1	1	
26	8CR-8398X-00	WASHER, PLATE	1	1	
27	95707-05300	NUT, FLANGE	1	1	
28	8FA-25867-00	BRACKET, MASTER CYLINDER	1	1	
29	91316-06022	BOLT	2	2	
30	90401-10015	BOLT, UNION	1	1	
31	90201-10118	WASHER, PLATE	2	2	
32	8FU-25970-01	PARKING BRAKE COMP.	1	1	
33	8FA-W0045-00	.PARKING BRAKE PAD KIT	1	1	
34	90387-06058	COLLAR	2	2	
35	90111-06042	BOLT,HEX. SOCKET BUTTON	2	2	
36	90501-120A0	SPRING, COMPRESSION	2	2	
37	90201-12161	WASHER, PLATE	2	2	
38	8FN-26351-10	CABLE, BRAKE	1	1	
39	8FA-83922-00	LEVER 2	1	1	
40	90387-06043	COLLAR	1	1	
41	92017-06014	BOLT, BUTTON HEAD	1	1	
42	90201-06050	WASHER, PLATE	1	1	
43	90387-081M9	COLLAR	1	1	
44	90111-08054	BOLT,HEX. SOCKET BUTTON	1	1	
45	90201-08403	WASHER, PLATE	2	2	

FIG. 26 CONTROL CABLE

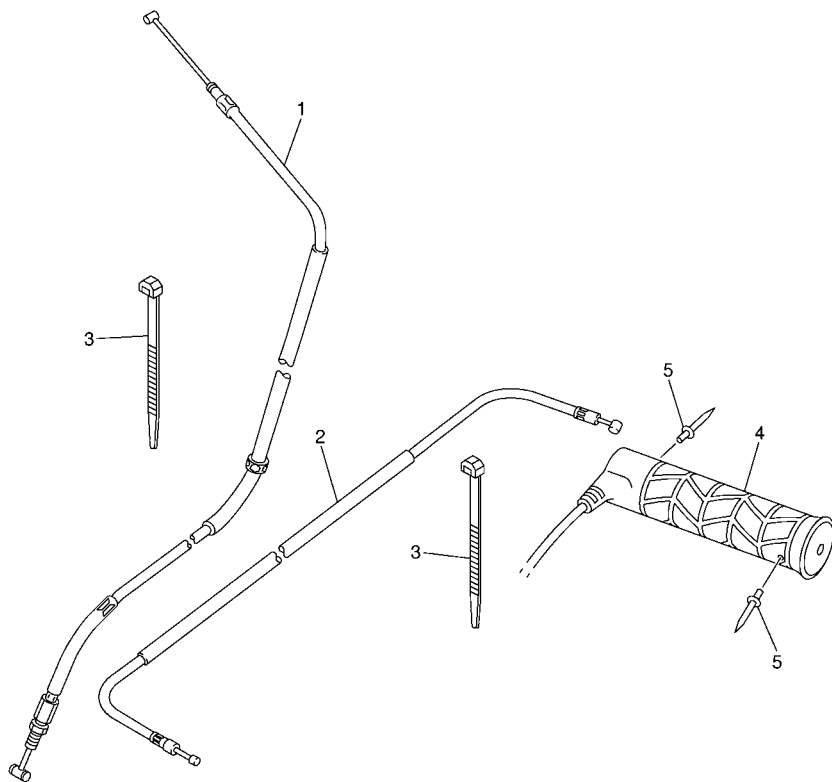

REF. NO.	PART NO.	DESCRIPTION	8GSC	8GSD		REMARKS
1	8FN-26311-00	CABLE, THROTTLE 1	1	1		
2	8FN-26330-00	STARTER CABLE ASSY	1	1		
3	90464-13073	CLAMP	2	2		
4	8DM-26240-02	GRIP ASSY	2	2		
5	90267-48014	RIVET, BLIND (4.8X15.1 BLACK)	4	4		

 8FN1100-E260

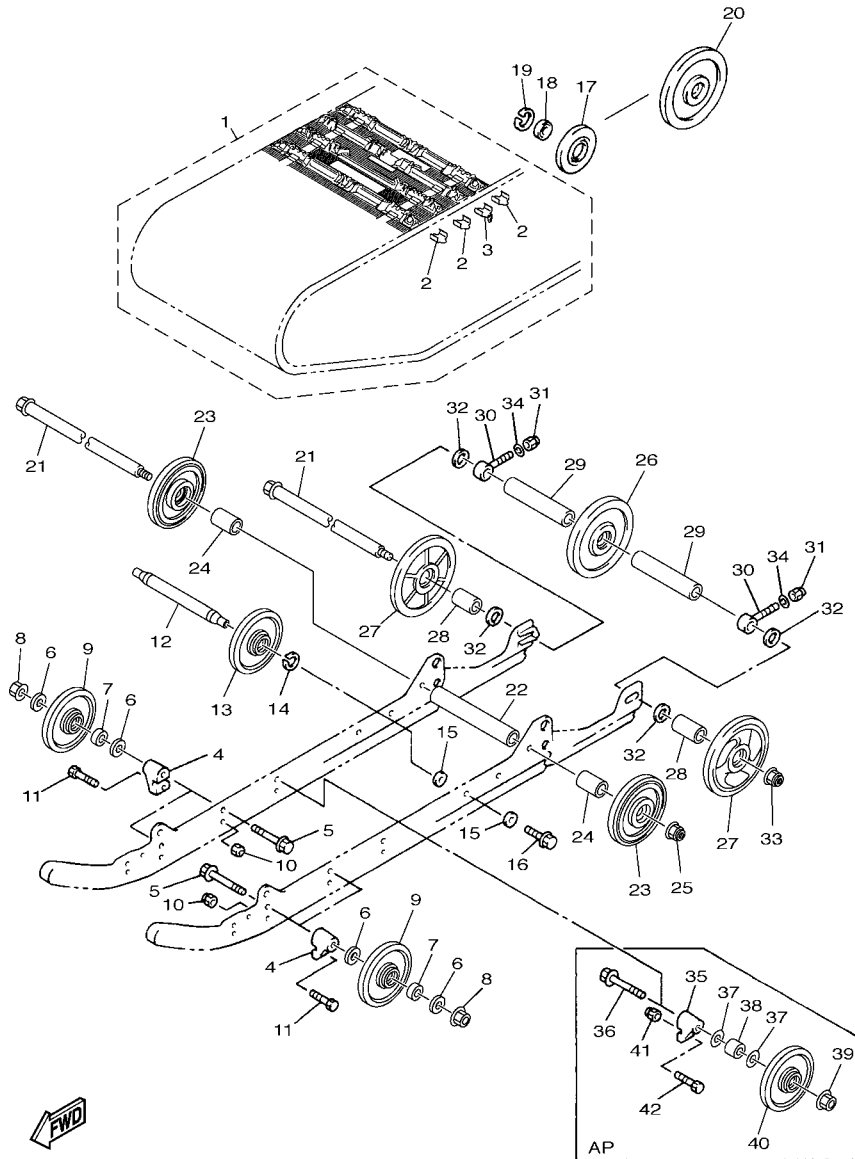

8GSA100-K270

FIG. 27 TRACK SUSPENSION 1

REF. NO.	PART NO.	DESCRIPTION	8GSC	8GSD	REMARKS
1	8FN-47110-01	TRACK ASSY	1	1	
2	8HR-47113-09	.PLATE, REINFORCEMENT	82	82	
3	8HR-47115-09	.METAL, SLIDE	42	42	
4	8CM-47419-10	BRACKET 7	4	4	
5	95817-10080	BOLT, FLANGE	4	4	
6	90201-100S0	WASHER, PLATE	8	8	
7	90387-10031	COLLAR	4	4	
8	95604-10200	NUT, SELF-LOCKING	4	4	
9	8ES-47310-00	SUSPENSION WHEEL ASSY	4	4	
10	95607-08200	NUT, SELF-LOCKING	4	4	
11	90101-08774	BOLT	4	4	
12	8FN-47486-00	SHAFT 4	1	1	
13	8ES-47310-00	SUSPENSION WHEEL ASSY	2	2	
14	99009-25400	CIRCLIP	2	2	
15	90201-100L3	WASHER, PLATE	4	4	
16	90105-10433	BOLT, FLANGE	2	2	
17	8AC-47320-00	SUSPENSION WHEEL COMP.	2	2	
18	93306-00444	BEARING	2	2	
19	99009-42500	CIRCLIP	2	2	
20	8AC-47550-00	GUIDE WHEEL ASSY	2	2	
21	83R-47520-10	REAR AXLE COMP.	2	2	
22	83R-47469-00	COLLAR 1	1	1	
23	8FM-47310-00	SUSPENSION WHEEL ASSY	2	2	
24	90387-203H0	COLLAR	2	2	
25	95607-14200	NUT, SELF-LOCKING	1	1	
26	8CR-47550-10	GUIDE WHEEL ASSY	1	1	
27	8EK-47550-10	GUIDE WHEEL ASSY	2	2	

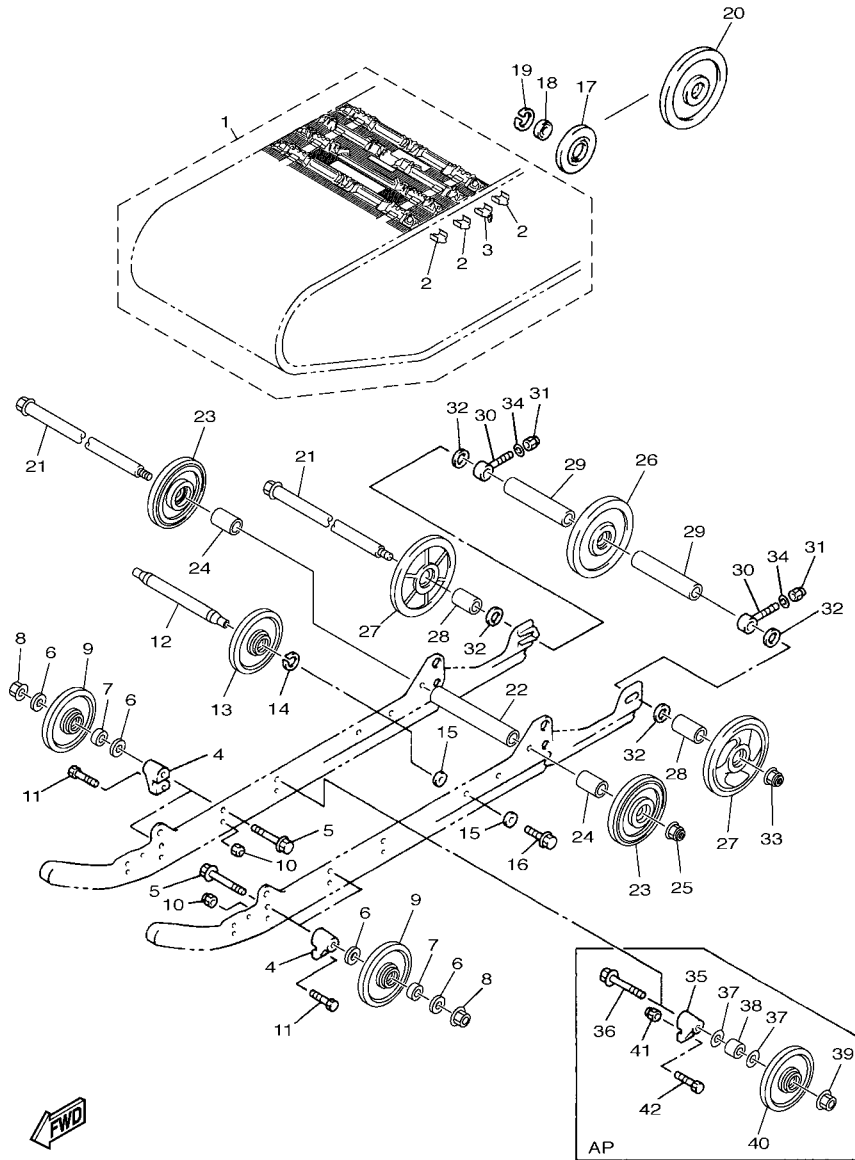

8GSA100-K270

FIG. 27 TRACK SUSPENSION 1

REF. NO.	PART NO.	DESCRIPTION	8GSC	8GSD		REMARKS
28	90387-20022	COLLAR	2	2		
29	90387-20023	COLLAR	2	2		
30	8DM-47479-00	COLLAR 3	2	2		
31	95707-10300	NUT, FLANGE	2	2		
32	90201-205R6	WASHER, PLATE	4	4		
33	95607-14200	NUT, SELF-LOCKING	1	1		
34	92907-10600	WASHER, PLATE	2	2		
35	8CM-47419-10	BRACKET 7	2	2		AP
36	95817-10080	BOLT, FLANGE	2	2		AP
37	90201-100S0	WASHER, PLATE	4	4		AP
38	90387-10031	COLLAR	2	2		AP
39	95604-10200	NUT, SELF-LOCKING	2	2		AP
40	8ES-47310-00	SUSPENSION WHEEL ASSY	2	2		AP
41	95607-08200	NUT, SELF-LOCKING	2	2		AP
42	90101-08774	BOLT	2	2		AP

FIG. 28 TRACK SUSPENSION 2

REF. NO.	PART NO.	DESCRIPTION	8GSC	8GSD	REMARKS
1	8AC-47411-10	FRAME, SLIDING 1	1	1	
2	8AC-47421-00	RUNNER, SLIDING 1	2	2	
3	90151-06010	SCREW, COUNTERSUNK	2	2	
4	8ED-47422-00	RUNNER, SLIDING 2	2	2	
5	90267-48194	RIVET, BLIND (4.8X28 SILVER)	2	2	
6	90201-047R8	WASHER, PLATE	2	2	
7	8AC-47414-10	FRAME, SLIDING 4	1	1	
8	8AC-47457-00	DAMPER 2	2	2	
9	8AC-47341-00	SPACER	2	2	
10	8AX-47458-00	PLATE, DAMPER	4	4	
11	90267-48199	RIVET, BLIND (4.8X28.3)	4	4	
12	8GS-47331-00	ARM, PIVOT 1	1	1	
13	8FN-47456-00	DAMPER 1	2	2	
14	90201-210U0	WASHER, PLATE	2	2	
15	90386-25002	BUSH	2	2	
16	90381-19111	BUSH, SOLID	2	2	
17	8GS-47465-00	SHAFT 1	1	1	
18	90105-103A1	BOLT, FLANGE	2	2	
19	83R-47485-02	SHAFT 3	1	1	
20	90387-105G6	COLLAR	2	2	
21	90201-100L3	WASHER, PLATE	2	2	
22	90105-10433	BOLT, FLANGE	2	2	
23	8CR-47448-00	HOOK 3	2	2	
24	95707-08500	NUT, FLANGE	4	4	
25	8CV-47495-00	STOPPER 1	2	2	
26	97007-06025	BOLT	4	4	
27	90201-06747	WASHER, PLATE	8	8	

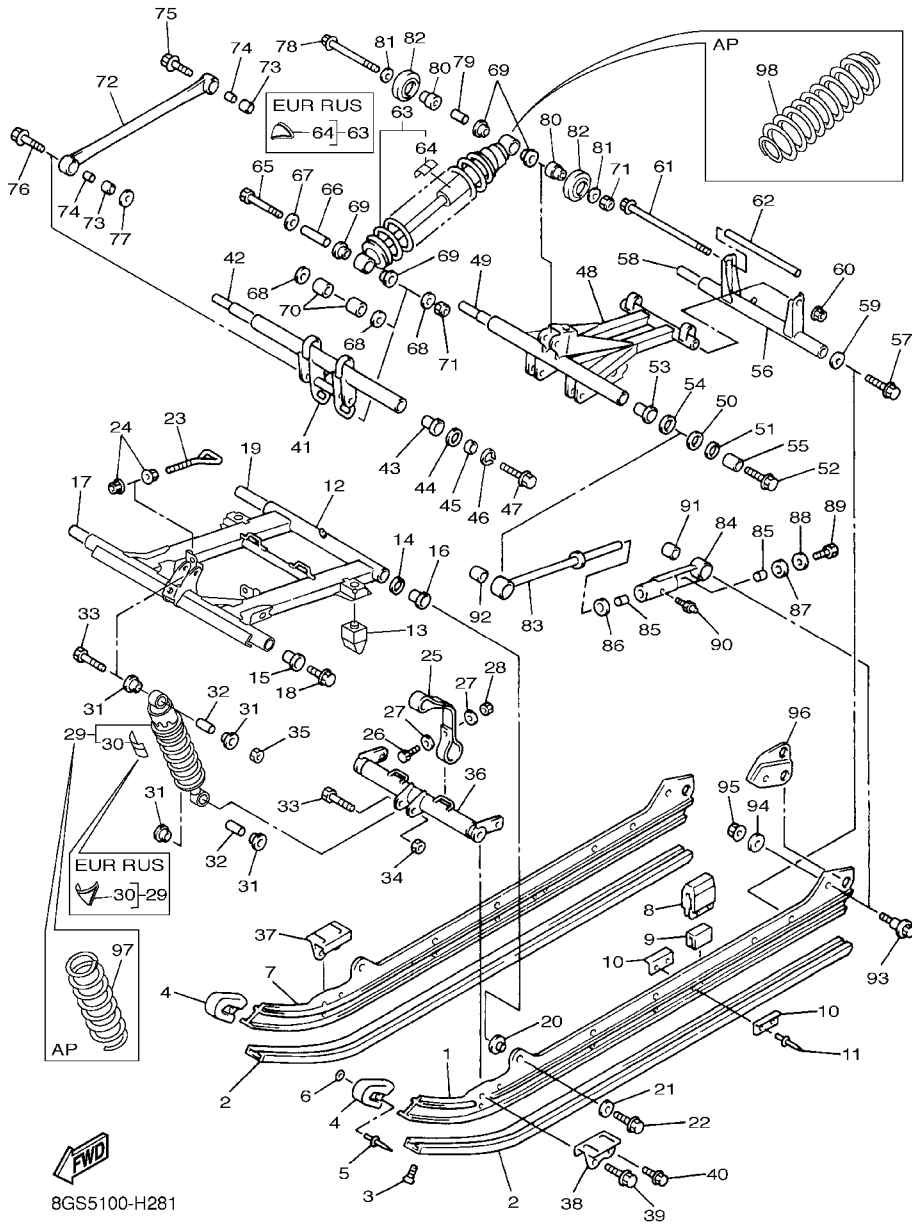

8GS5100-H281

FIG. 28 TRACK SUSPENSION 2

REF. NO.	PART NO.	DESCRIPTION	8GSC	8GSD	REMARKS
28	95707-06300	NUT, NYLON	4	4	
29	8FN-47481-30	SHOCK ABSORBER 2	1		
	8FN-47481-40	SHOCK ABSORBER 2		1	UR FOR EUR,RUS
	8FN-47481-50	SHOCK ABSORBER 2		1	UR FOR JPN
30	4AA-22259-60	.LABEL, WARNING	1		
	4AA-22259-40	.LABEL, WARNING		1	UR FOR EUR,RUS
	4AA-22259-50	.LABEL, WARNING		1	UR FOR JPN
31	90381-14101	BUSH, SOLID	4	4	
32	90387-105G5	COLLAR	2	2	
33	90101-10738	BOLT	2	2	
34	90185-10110	NUT, SELF-LOCKING	1	1	
35	95607-10100	NUT, U	1	1	
36	8AC-47418-00	BRACKET 4	1	1	
37	8DF-47463-01	BRACKET 5	1	1	
38	8DF-47464-01	BRACKET 6	1	1	
39	90105-10433	BOLT, FLANGE	2	2	
40	90105-08450	BOLT, FLANGE	2	2	
41	8AC-47416-01	BRACKET 2	1	1	
42	8FN-47488-00	SHAFT 6	1	1	
43	90381-22099	BUSH, SOLID	2	2	
44	90201-207J5	WASHER, PLATE	2	2	
45	90387-2004V	COLLAR	2	2	
46	99009-20400	CIRCLIP	2	2	
47	90105-103A1	BOLT, FLANGE	2	2	
48	8GS-47332-00	ARM, PIVOT 2	1	1	
49	8AC-47475-00	SHAFT 2	1	1	
50	90201-266L1	WASHER, PLATE	2	2	

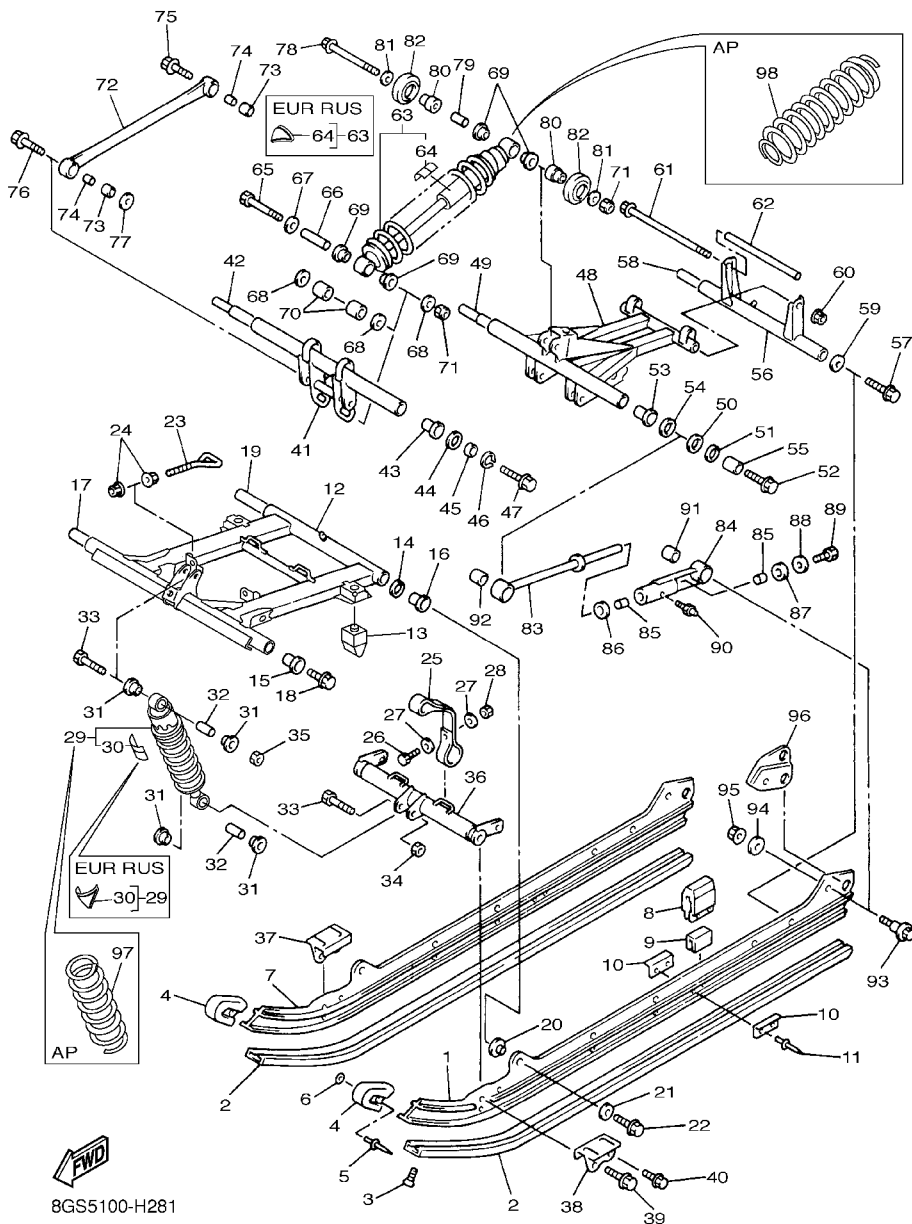

8GS5100-H281

FIG. 28 TRACK SUSPENSION 2

REF. NO.	PART NO.	DESCRIPTION	8GSC	8GSD	REMARKS
51	90201-250T6	WASHER, PLATE	2	2	
52	90105-103A1	BOLT, FLANGE	2	2	
53	90381-28108	BUSH, SOLID	2	2	
54	90201-286K9	WASHER, PLATE (T1.0)	2	2	
55	90387-2515E	COLLAR	2	2	
56	8AC-47417-00	BRACKET 3	1	1	
57	90105-10433	BOLT, FLANGE	2	2	
58	83R-47485-02	SHAFT 3	1	1	
59	90201-10136	WASHER, PLATE	2	2	
60	95607-08200	NUT, SELF-LOCKING	1	1	
61	95827-08220	BOLT, FLANGE	1	1	
62	90387-083G6	COLLAR	1	1	
63	8FN-47480-30	SHOCK ABSORBER	1		
	8FN-47480-40	SHOCK ABSORBER	1		UR FOR EUR,RUS
	8FN-47480-50	SHOCK ABSORBER	1		UR FOR JPN
64	4AA-22259-60	.LABEL, WARNING	1		
	4AA-22259-40	.LABEL, WARNING	1		UR FOR EUR,RUS
	4AA-22259-50	.LABEL, WARNING	1		UR FOR JPN
65	8AC-4631K-00	BOLT, ADJUSTING	1	1	
66	90387-1009S	COLLAR	1	1	
67	90201-103U4	WASHER, PLATE	1	1	
68	90201-100U1	WASHER, PLATE	3	3	
69	90381-14101	BUSH, SOLID	4	4	
70	90387-1404R	COLLAR	2	2	
71	95607-10100	NUT, U	2	2	
72	8CR-47494-01	ROD, RELAY	2	2	
73	90381-14109	BUSH, SOLID	4	4	

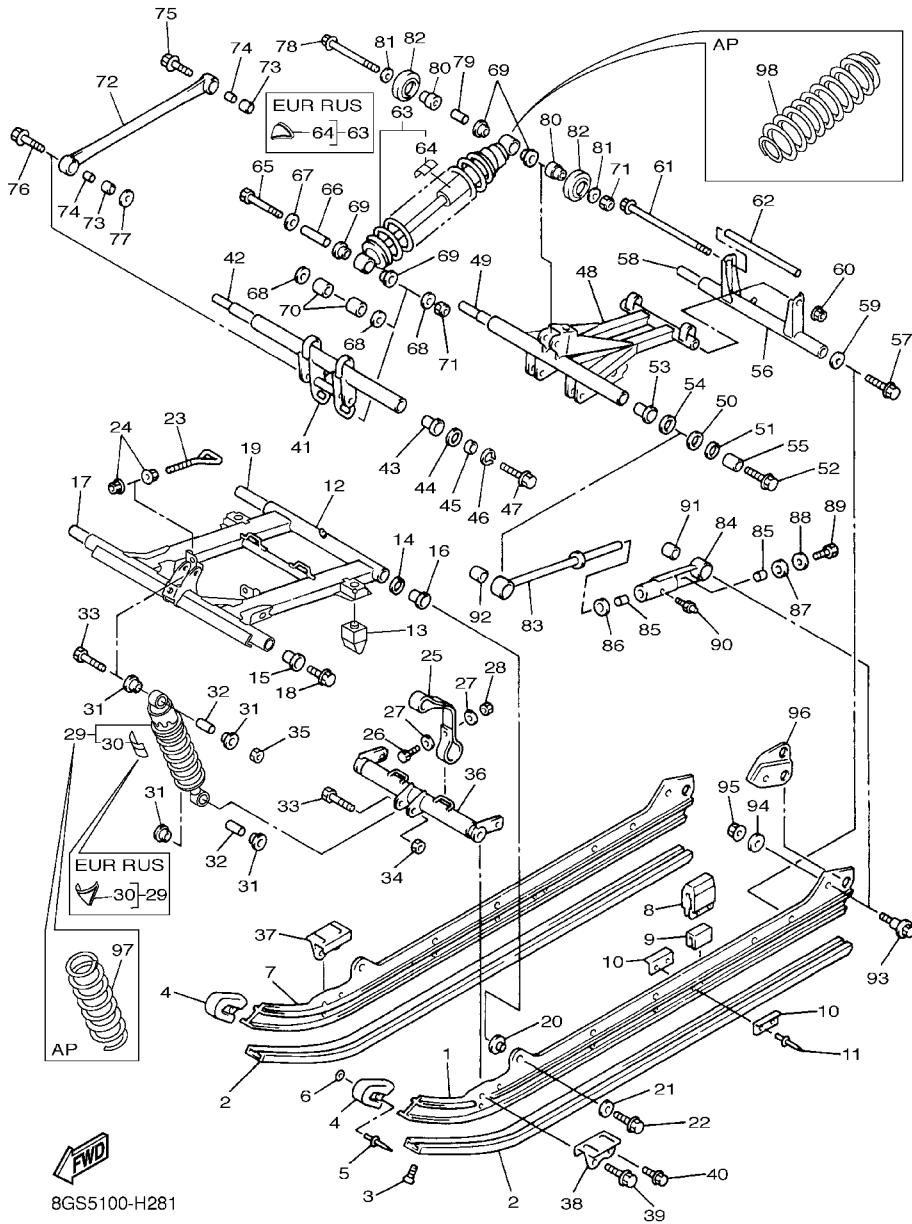

8GS5100-H281

FIG. 28 TRACK SUSPENSION 2

REF. NO.	PART NO.	DESCRIPTION	8GSC	8GSD	REMARKS
74	90387-100X3	COLLAR	4	4	
75	90105-10739	BOLT, FLANGE	2	2	
76	90105-10436	BOLT, FLANGE	2	2	
77	90201-100U1	WASHER, PLATE	2	2	
78	90105-10105	BOLT, FLANGE	1	1	
79	90387-105G5	COLLAR	1	1	
80	8AC-47366-00	COLLAR 2	2	2	
81	90201-10136	WASHER, PLATE	2	2	
82	8AC-47310-10	SUSPENSION WHEEL ASSY	2	2	
83	8AC-4745A-10	ROD, CONTROL 1	2	2	
84	8CR-4745B-00	ROD, CONTROL 2	2	2	
85	90384-16251	BUSH, BIMETAL FORMED	4	4	
86	90202-16229	WASHER, PLATE	2	2	
87	90202-16232	WASHER, PLATE	2	2	
88	90201-106F2	WASHER, PLATE	2	2	
89	97027-10025	BOLT, HEXAGON	2	2	
90	93700-06004	NIPPLE, GREASE	2	2	
91	90380-22232	BUSH, SOLID	2	2	
92	90380-28235	BUSH, SOLID	2	2	
93	8DF-47367-00	SCREW, REAR PIVOT	2	2	
94	90201-101U2	WASHER, PLATE	2	2	
95	95607-10200	NUT, U FLANGE	2	2	
96	8AC-47349-00	BRACKET, ARM PIVOT	2	2	
97	8FN-47336-00	SPRING 1 (K=14.7N/MM)	1	1	AP
	8FN-47336-10	SPRING 1 (K=17.7N/MM)	1	1	AP
	8FN-47336-20	SPRING 1 (K=20.6N/MM)	1	1	AP
98	8FN-47489-00	SPRING 1 (K=63.7N/MM)	1	1	AP

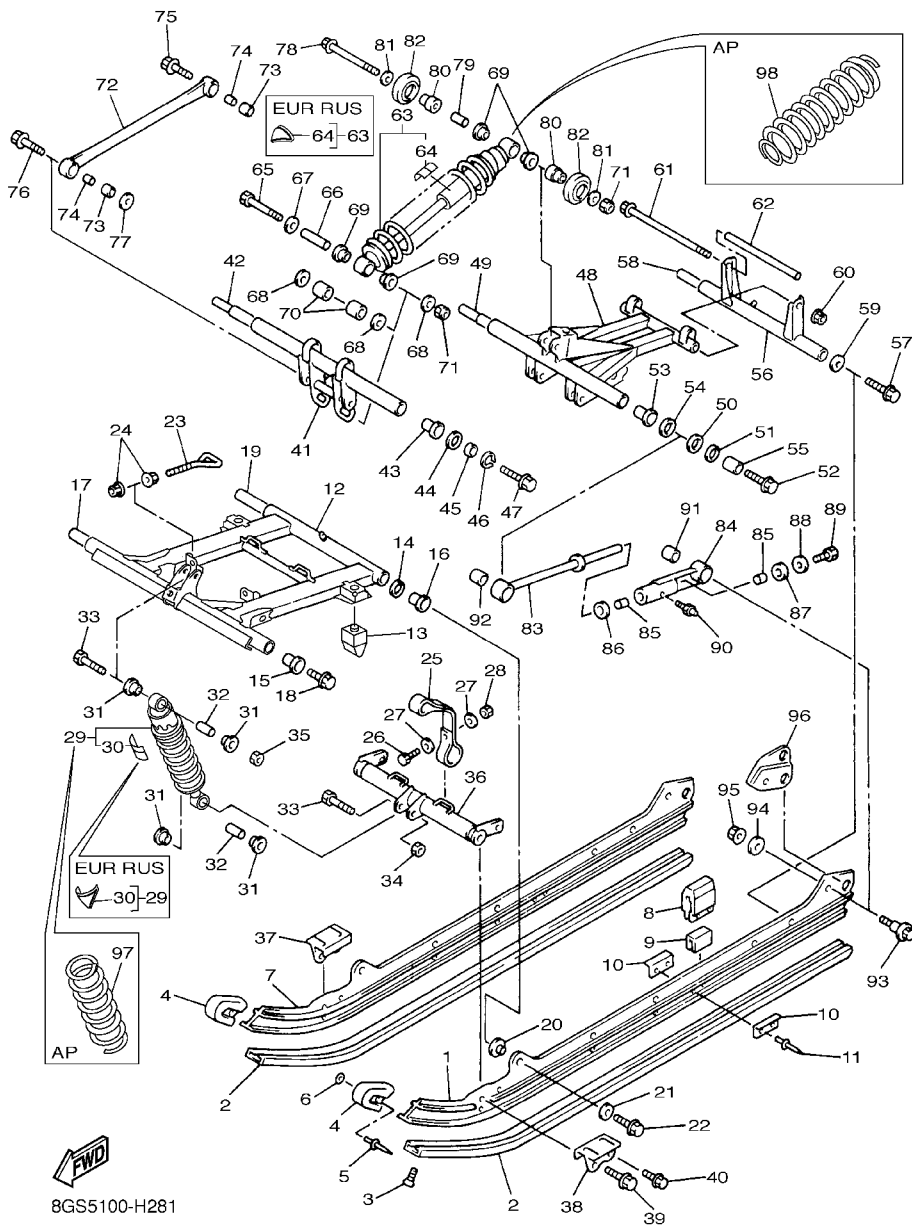

8GS5100-H281

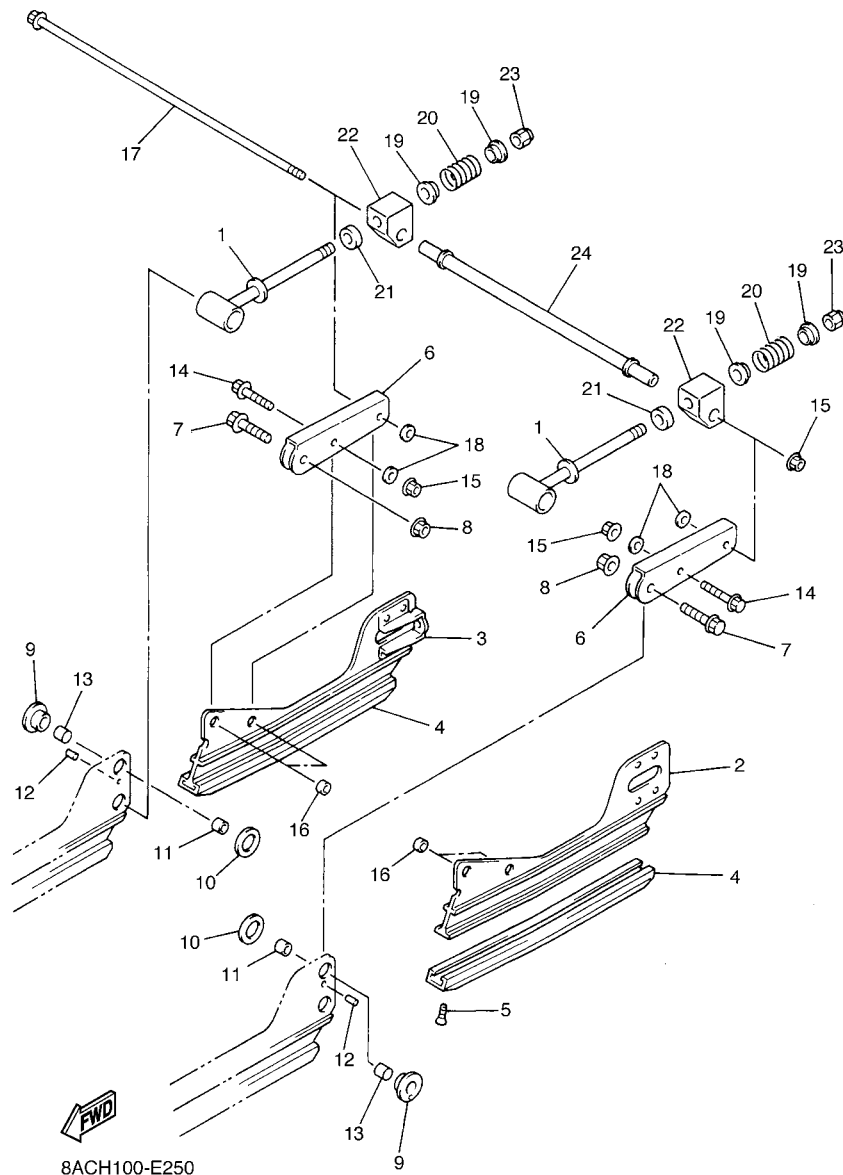
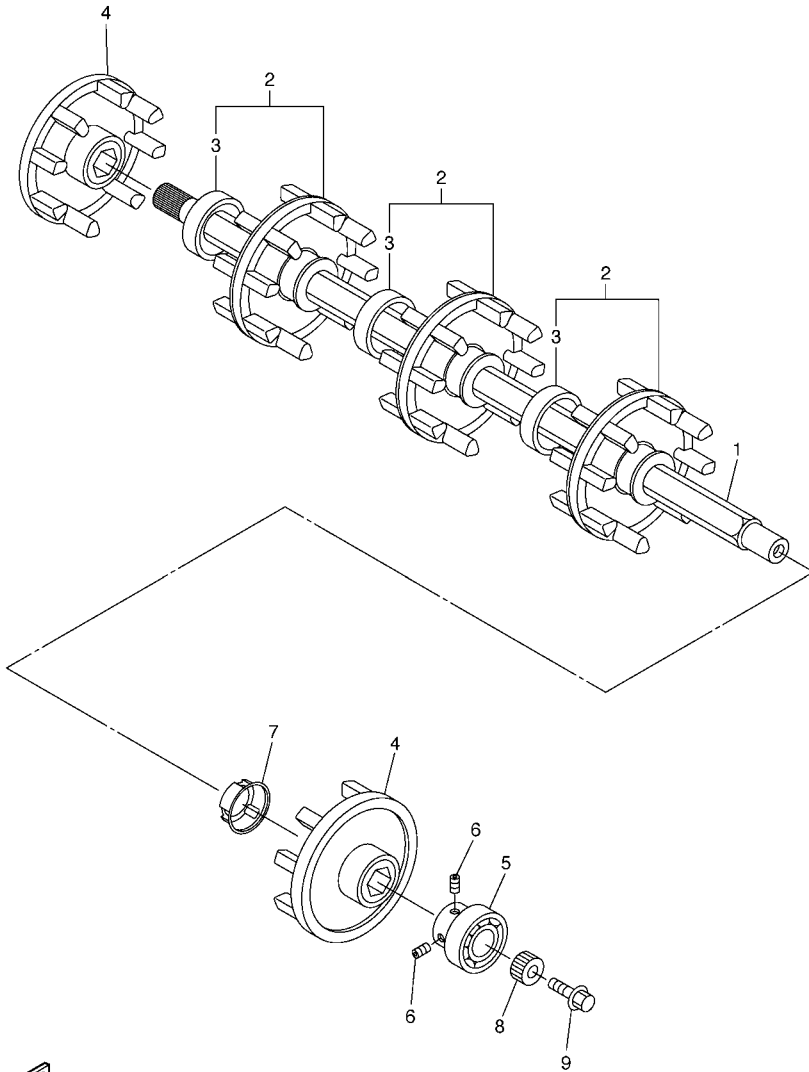

FIG. 29 TRACK SUSPENSION 3

REF. NO.	PART NO.	DESCRIPTION	8GSC	8GSD	REMARKS
1	83R-47337-00	SHAFT, PIVOT	2	2	
2	8FM-W4741-10	FRAME, SLIDING	1	1	
3	8FM-W4741-10	FRAME, SLIDING	1	1	
4	8AC-47424-00	RUNNER, SLIDING 4	2	2	
5	90151-06010	SCREW, COUNTERSUNK	2	2	
6	8FM-47333-00	ARM, PIVOT 3	2	2	
7	95817-10030	BOLT, FLANGE	2	2	
8	90185-10115	NUT, SELF-LOCKING	2	2	
9	90387-1815A	COLLAR	2	2	
10	90202-22238	WASHER, PLATE	2	2	
11	90387-1014Y	COLLAR	2	2	
12	91609-30008	PIN, SPRING	2	2	
13	90380-16109	BUSH, SOLID	2	2	
14	95817-08035	BOLT, FLANGE	2	2	
15	95607-08200	NUT, SELF-LOCKING	3	3	
16	90387-082J1	COLLAR	4	4	
17	90105-08483	BOLT, FLANGE	1	1	
18	90201-08649	WASHER, PLATE	4	4	
19	83R-23768-00	SEAT, SPRING 1	4	4	
20	90501-407E4	SPRING, COMPRESSION	2	2	
21	83R-47335-00	SPRING	2	2	
22	83R-47446-00	HOOK 1	2	2	
23	95707-12300	NUT, FLANGE	2	2	
24	8AC-47478-00	COLLAR 2	1	1	





8FN1100-E300

FIG. 30 TRACK DRIVE 1

REF. NO.	PART NO.	DESCRIPTION	8GSC	8GSD		REMARKS
1	8GS-47511-00	AXLE, FRONT	1	1		
2	8FN-W4753-00	WHEEL, SPROCKET 1	3	3		
3	90387-514Y2	.COLLAR	1	1		
4	8FN-47532-00	WHEEL, SPROCKET 2	2	2		
5	93306-20589	BEARING	1	1		
6	90113-06064	BOLT, SET	2	2		
7	8FN-47377-00	CAP	1	1		
8	8EK-47715-00	JOINT	1	1		
9	95827-10025	BOLT, FLANGE	1	1		

FIG. 31 TRACK DRIVE 2

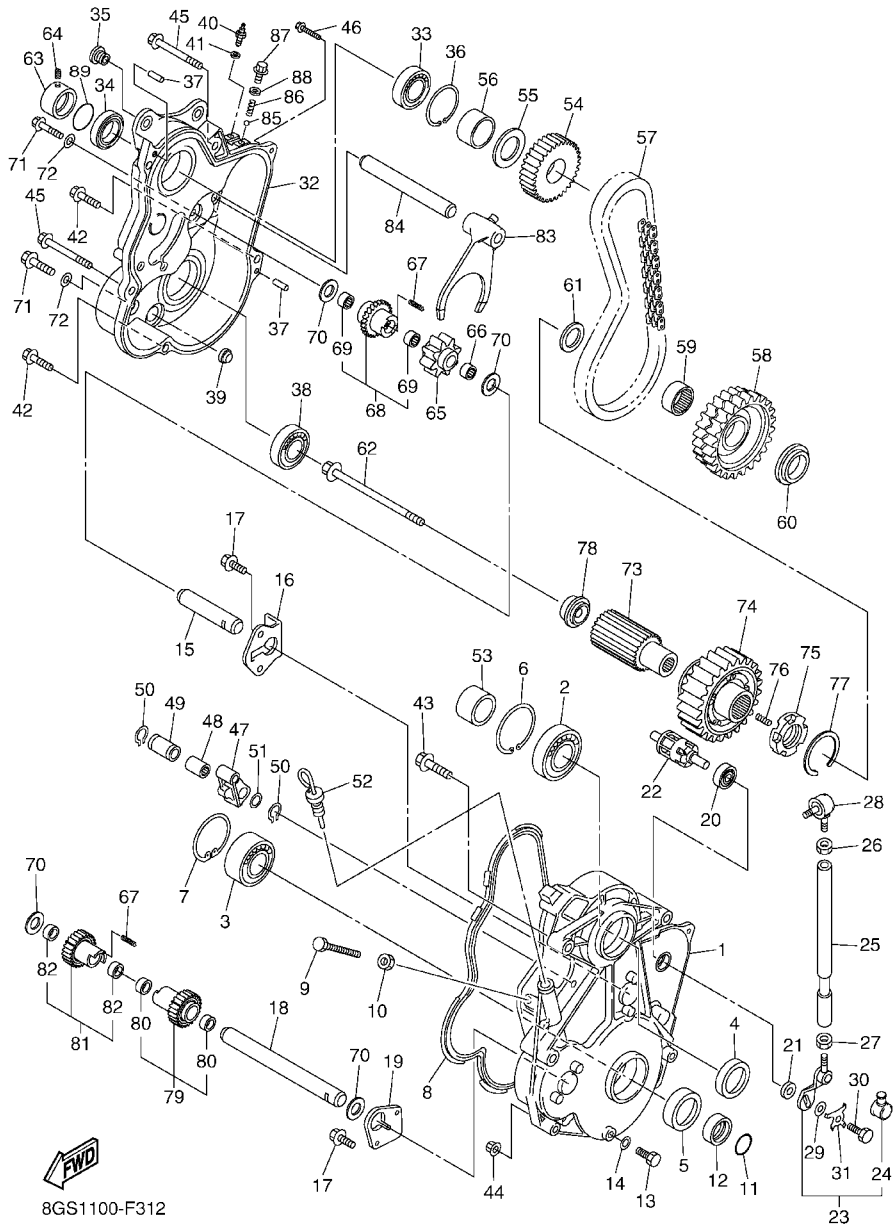
REF. NO.	PART NO.	DESCRIPTION	8GSC	8GSD	REMARKS
1	8GS-47541-00	HOUSING, CHAIN	1	1	
2	93306-20601	BEARING	1	1	
3	93304-20511	BEARING	1	1	
4	93102-30012	OIL SEAL	1	1	
5	93102-35010	OIL SEAL	1	1	
6	99009-62500	CIRCLIP	1	1	
7	99009-52500	CIRCLIP	1	1	
8	8GS-47558-00	RING, HOUSING	1	1	
9	90101-10357	BOLT	1	1	
10	95307-10600	NUT	1	1	
11	93210-25071	O-RING	1	1	
12	90387-2508C	COLLAR	1	1	
13	97007-08014	BOLT	1	1	
14	90210-08017	WASHER, SEAL	1	1	
15	8GS-1761A-00	SHAFT, 1	1	1	
16	8CW-47591-00	PLATE	1	1	
17	90105-060A6	BOLT, FLANGE	4	4	
18	8GS-1761E-00	SHAFT 2	1	1	
19	8GS-47591-00	PLATE	1	1	
20	93306-00208	BEARING	1	1	
21	93102-15212	OIL SEAL	1	1	
22	8GS-18541-01	CAM, SHIFT	1	1	
23	8GS-18191-00	LEVER	1	1	
24	2H9-18154-00	.COVER, DUST	1	1	
25	8GS-18115-00	ROD, SHIFT	1	1	
26	90170-08358	NUT	1	1	
27	95307-08700	NUT	1	1	



8GS1100-F312

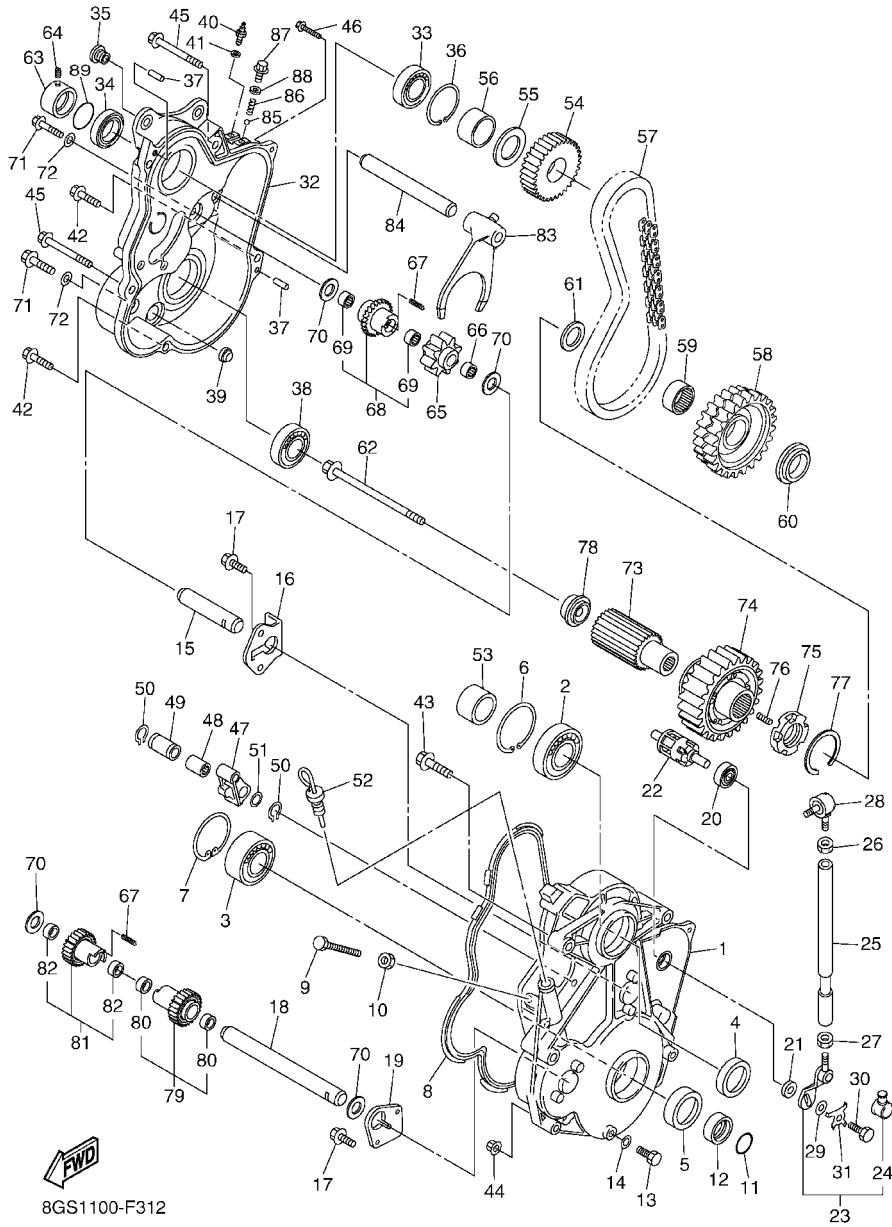

8GS1100-F312

FIG. 31 TRACK DRIVE 2

REF. NO.	PART NO.	DESCRIPTION	8GSC	8GSD	REMARKS
28	3X3-18157-10	JOINT 2	1	1	
29	90201-06099	WASHER, PLATE	1	1	
30	90101-06047	BOLT	1	1	
31	8GS-47554-01	WASHER, LOCK	1	1	
32	8GS-47543-00	CAP, HOUSING	1	1	
33	93306-20511	BEARING	1	1	
34	93102-35010	OIL SEAL	1	1	
35	90179-10679	NUT	2	2	
36	99009-52500	CIRCLIP	1	1	
37	93606-20044	PIN, DOWEL	2	2	
38	93306-00711	BEARING	1	1	
39	3Y1-15361-00	GAUGE, LEVEL	1	1	
40	5LP-82540-01	NEUTRAL SWITCH ASSY	1	1	
41	90430-10148	GASKET	1	1	
42	95822-08030	BOLT, FLANGE	3	3	
43	95822-10045	BOLT, FLANGE	2	2	
44	95602-10200	NUT, U FLANGE	1	1	
45	95822-10090	BOLT, FLANGE	2	2	
46	95822-06025	BOLT, FLANGE	1	1	
47	8ES-47613-00	HOLDER	1	1	
48	93311-32685	BEARING	1	1	
49	90387-22005	COLLAR	1	1	
50	99009-26400	CIRCLIP	2	2	
51	90201-266P2	WASHER, PLATE	1	1	
52	8GS-47546-00	LEVEL, OIL	1	1	
53	90387-30005	COLLAR	1	1	
54	8FA-17682-00	SPROCKET, CHAIN DRIVE (20T)	1	1	

FIG. 31 TRACK DRIVE 2

REF. NO.	PART NO.	DESCRIPTION	8GSC	8GSD	REMARKS
55	90208-26002	WASHER, CONICAL SPRING	1	1	
56	90387-26007	COLLAR	1	1	
57	94890-09068	CHAIN (68L)	1	1	
58	8GS-47587-99	SPROCKET, CHAIN DRIVEN	1	1	
59	93317-33179	BEARING	1	1	
60	90387-2008G	COLLAR	1	1	
61	90201-320S3	WASHER, PLATE	1	1	
62	90105-10223	BOLT, FLANGE	1	1	
63	90387-25018	COLLAR	1	1	
64	90113-06064	BOLT, SET	1	1	
65	8FB-17692-00	SPROCKET, DRIVE (18T)	1	1	
66	93317-21578	BEARING	1	1	
67	90501-060A1	SPRING, COMPRESSION	2	2	
68	8GS-1714A-01	REVERSE PINION ASSY.	1	1	
69	93317-21578	BEARING	2	2	
70	90201-16245	WASHER, PLATE	4	4	
71	90105-060A6	BOLT, FLANGE	2	2	
72	90210-06006	WASHER, SEAL	2	2	
73	8GS-47571-00	JOURNAL 1	1	1	
74	8GS-17243-01	GEAR, REVERSE WHEEL	1	1	
75	8CW-17492-00	DOG, TRANSMISSION SHIFT	1	1	
76	90501-066J5	SPRING, COMPRESSION	5	5	
77	93440-39175	CIRCLIP	1	1	
78	8GS-47564-00	COLLAR	1	1	
79	8GS-17210-00	1ST WHEEL GEAR ASSY	1	1	

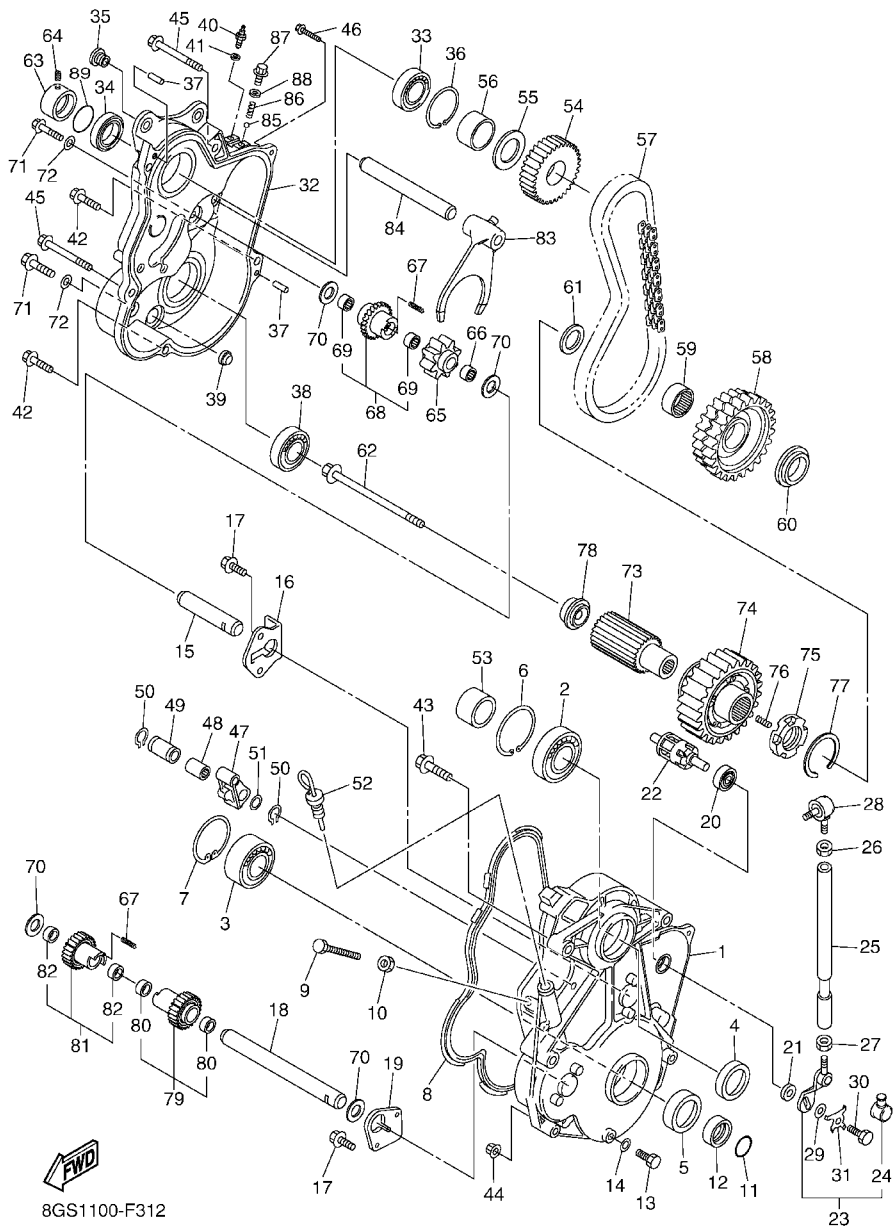
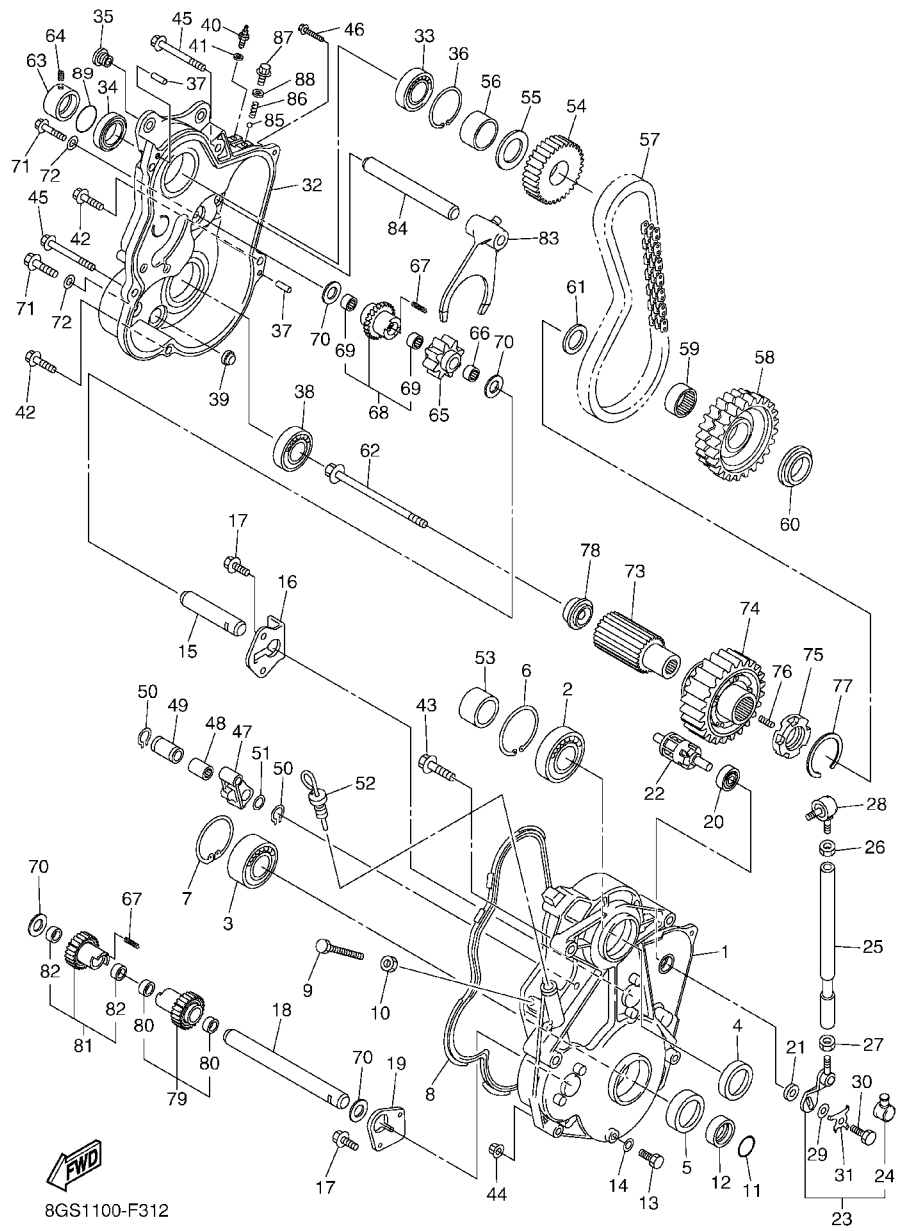
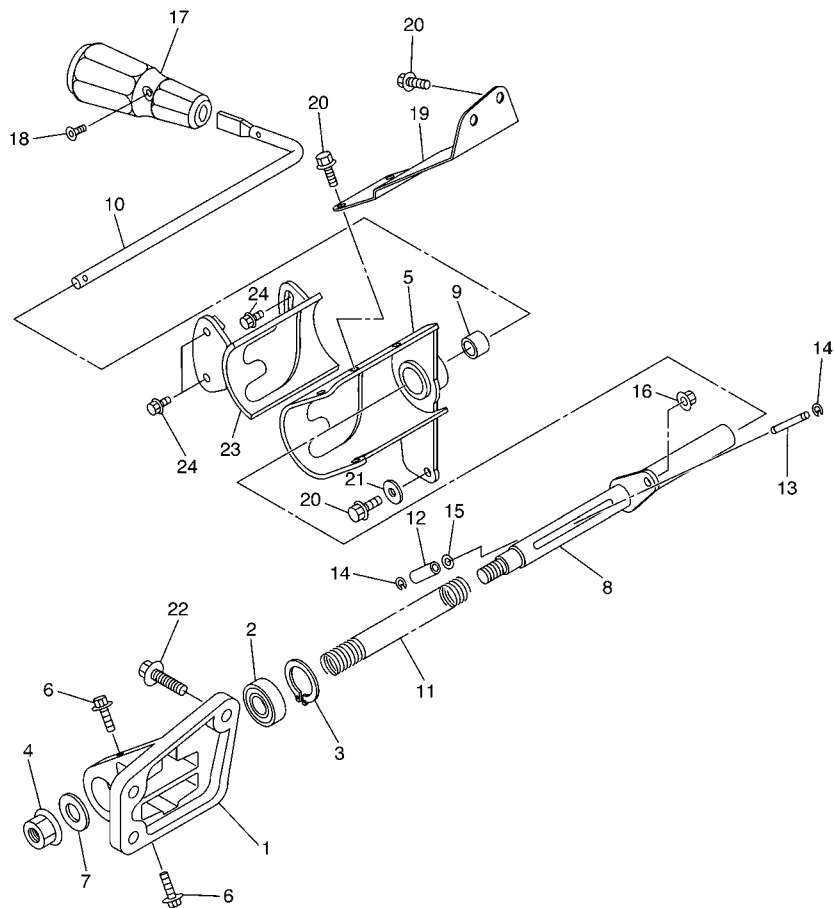

FIG. 31 TRACK DRIVE 2

REF. NO.	PART NO.	DESCRIPTION	8GSC	8GSD	REMARKS
80	93317-21578	.BEARING	2	2	
81	8GS-17110-01	1ST PINION GEAR ASSY	1	1	
82	93317-21578	.BEARING	2	2	
83	8GS-18511-00	FORK, SHIFT 1	1	1	
84	8GS-18531-00	BAR, SHIFT FORK GUIDE 1	1	1	
85	93503-08007	BALL	1	1	
86	90501-10353	SPRING, COMPRESSION	1	1	
87	90105-14003	BOLT, FLANGE	1	1	
88	90430-14043	GASKET	1	1	
89	93210-25642	O-RING	1	1	



8GS1100-F312



8GS3100-G320

FIG. 32 TRACK DRIVE 3

REF. NO.	PART NO.	DESCRIPTION	8GSC	8GSD	REMARKS
1	8GS-18164-00	KNOB, SHIFTER	1	1	
2	93306-20212	BEARING	1	1	
3	99009-35500	CIRCLIP	1	1	
4	95607-12200	NUT, SELF-LOCKING	1	1	
5	8GS-18161-01	GUIDE, PLATE STOPPER	1	1	
6	95827-08016	BOLT, FLANGE	2	2	
7	90201-12317	WASHER, PLATE	1	1	
8	8GS-18104-01	SHIFT GUIDE COMP.	1	1	
9	90384-19001	BUSH, BIMETAL FORMED	1	1	
10	8GS-18152-01	LEVER, SHIFT 4	1	1	
11	90501-130A0	SPRING, COMPRESSION	1	1	
12	90387-06059	COLLAR	1	1	
13	90249-06002	PIN	1	1	
14	93410-06053	CIRCLIP	2	2	
15	90201-06042	WASHER, PLATE	1	1	
16	95602-06200	NUT, SELF-LOCKING	1	1	
17	8GS-18174-00	KNOB, SHIFT LEVER	1	1	
18	90151-05048	SCREW, COUNTERSUNK	1	1	
19	8GS-18128-01	BRACKET	1	1	
20	95822-08014	BOLT, FLANGE	5	5	
21	90201-08060	WASHER, PLATE	1	1	
22	95822-08020	BOLT, FLANGE	3	3	
23	8GS-18179-01	GUIDE	1	1	
24	95812-06012	BOLT, FLANGE	3	3	

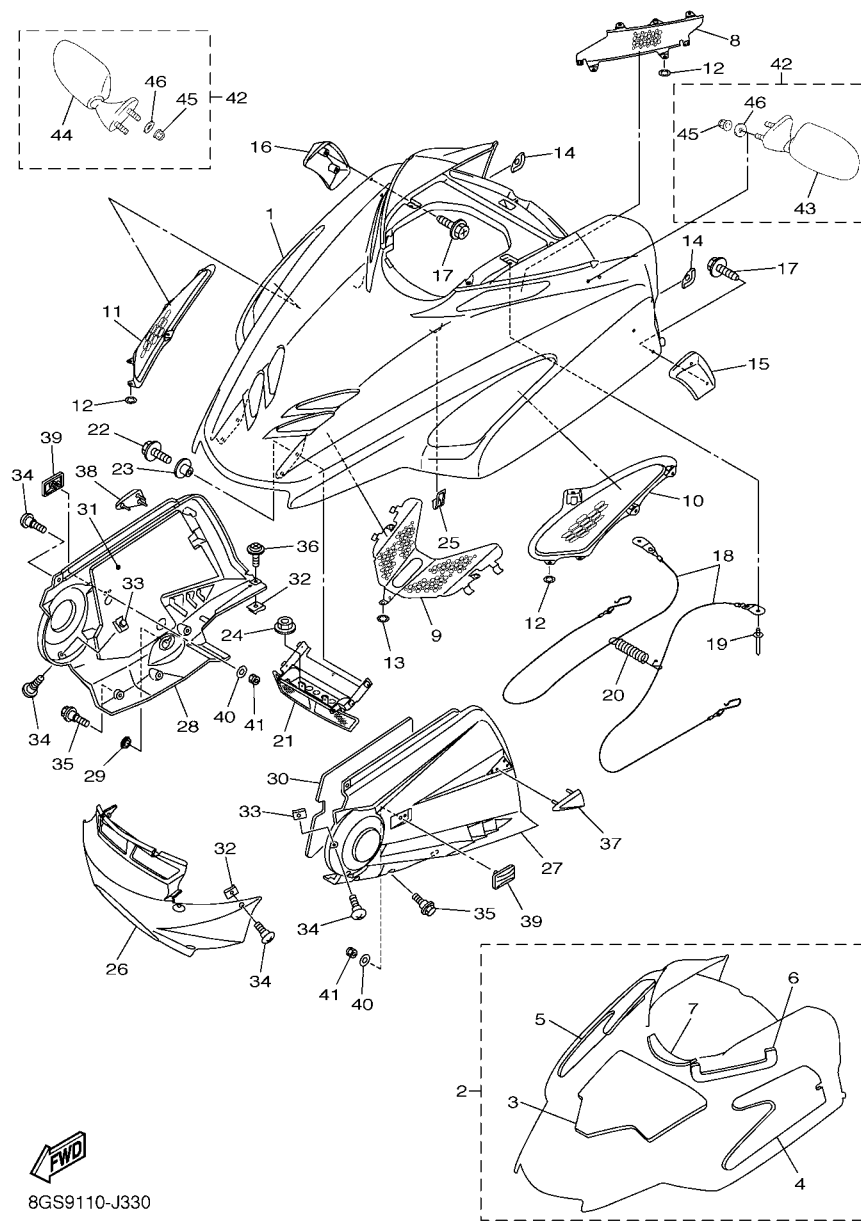

8GS9110-J330

FIG. 33 SHROUD

REF. NO.	PART NO.	DESCRIPTION	8GSC	8GSD	REMARKS
1	8FN-77111-00-P2	SHROUD	1	1	DRMK
2	8FN-W7726-00	LINING SET	1	1	
3	8FN-77271-00	.DAMPER, NOISE 11	1	1	
4	8FN-77272-00	.DAMPER, NOISE 12	1	1	
5	8FN-77273-00	.DAMPER, NOISE 13	1	1	
6	8FN-77264-00	.LINING, SHROUD 4	1	1	
7	8DS-84366-00	.DAMPER, HEADLIGHT 1	1	1	
8	8FN-77130-00	LOUVER COMP.	1	1	
9	8FN-77134-00	LOUVER 4	1	1	
10	8FN-77109-00	LOUVER 5	1	1	
11	8FN-77108-00	LOUVER 6	1	1	
12	90183-05068	NUT, SPRING	14	14	
13	90183-08065	NUT, SPRING	3	3	
14	8FA-77167-10	TRIM 3	2	2	
15	8FN-77161-00	STRIP, WEATHER 1	1	1	
16	8FN-77162-00	STRIP, WEATHER 2	1	1	
17	97702-50016	SCREW, TAPPING	4	4	
18	8FN-77118-00	STOPPER, SHROUD	2	2	
19	90267-48018	RIVET, BLIND (4.8X18.6 BLACK)	2	2	
20	89A-77159-00	CLAMP, ROD	2	2	
21	8FN-77140-00	HINGE ASSY	1	1	
22	95802-06016	BOLT, FLANGE	4	4	
23	90387-06681	COLLAR	4	4	
24	95602-06200	NUT, SELF-LOCKING	2	2	
25	8FA-77135-00	CLAMP 1	1	1	
26	8FN-21912-00	PANEL, SUB FRAME 1	1	1	
27	8ES-2197H-01	HOOD 3	1	1	

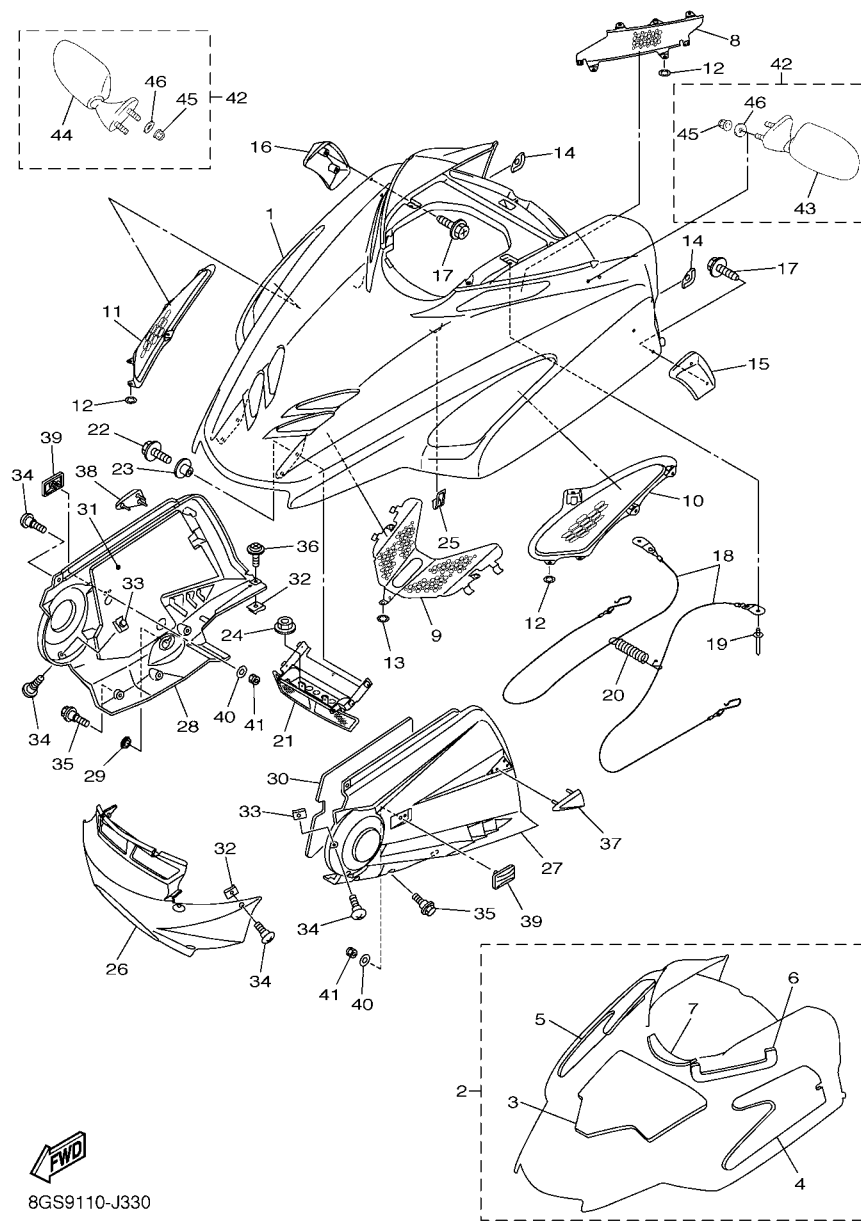

8GS9110-J330

FIG. 33 SHROUD

REF. NO.	PART NO.	DESCRIPTION	8GSC	8GSD	REMARKS
28	8GS-2198H-00	HOOD 4	1	1	
29	90338-30256	PLUG	1	1	
30	8ES-77276-00	DAMPER, NOISE 16	1	1	
31	8GS-77277-00	DAMPER, NOISE 17	1	1	
32	90183-06053	NUT, SPRING	8	8	
33	90183-06100	NUT, SPRING	6	6	
34	90154-06009	SCREW, BINDING	12	12	
35	90109-06220	BOLT	6	6	
36	90159-06011	SCREW, WITH WASHER	2	2	
37	8FA-77561-00	PROTECTOR, SIDE 1	1	1	
38	8FA-77562-00	PROTECTOR, SIDE 2	1	1	
39	8FR-77185-00	PLATE 1	2	2	
40	90201-05036	WASHER, PLATE	2	2	
41	95702-05300	NUT, NYLON	2	2	
42	8CR-W2628-10	REAR VIEW MIRROR SET	1	1	
43	4SV-26280-00	.REAR VIEW MIRROR ASSY (LEFT)	1	1	
44	4SV-26290-00	.REAR VIEW MIRROR ASSY (RIGHT)	1	1	
45	95602-06200	.NUT, SELF-LOCKING	4	4	
46	90201-06072	.WASHER, PLATE	4	4	

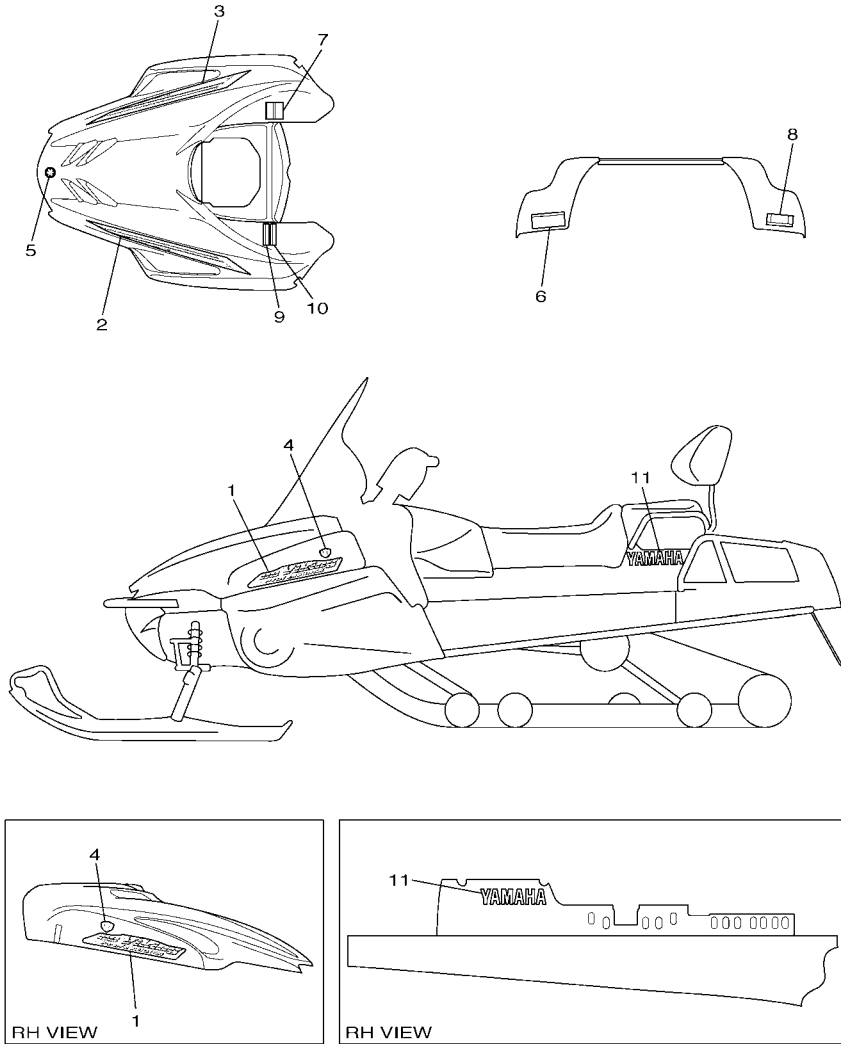

8GS5100-H340

FIG. 34 EMBLEM

REF. NO.	PART NO.	DESCRIPTION	8GSC	8GSD		REMARKS
1	8GS-77141-10	EMBLEM 1	2	2		
2	8FN-7711L-30	GRAPHIC, SHROUD	1	1		
3	8FN-7711M-30	GRAPHIC, SHROUD	1	1		
4	8FN-7715A-00	EMBLEM 3D	2	2		
5	8AC-2414B-01	EMBLEM	1	1		
6	8DM-77761-E0	LABEL, WARNING 1	1			
	8DM-77761-S0	LABEL, WARNING 1		1		UR FOR EUR
	8GS-77761-R1	LABEL, WARNING 1		1		UR FOR RUS
	8BY-77761-J0	LABEL, WARNING 1		1		UR FOR JPN
7	8FN-77761-E0	LABEL, WARNING 1	1			
	8FN-77761-S0	LABEL, WARNING 1		1		UR FOR EUR
	8FN-77761-R1	LABEL, WARNING 1		1		UR FOR RUS
	8FN-77761-J0	LABEL, WARNING 1		1		UR FOR JPN
8	8GS-77763-E0	LABEL, WARNING 3	1			
	8GS-77763-S0	LABEL, WARNING 3		1		UR FOR EUR,RUS
	8GS-77763-J0	LABEL, WARNING 3		1		UR FOR JPN
9	8ET-2815K-00	LABEL, NOTICE WINDSHIELD 1	1			
10	8ET-2815K-10	LABEL, NOTICE WINDSHIELD 1	1			
11	99246-00200	EMBLEM, YAMAHA	2	2		

FIG. 35 WINDSHIELD

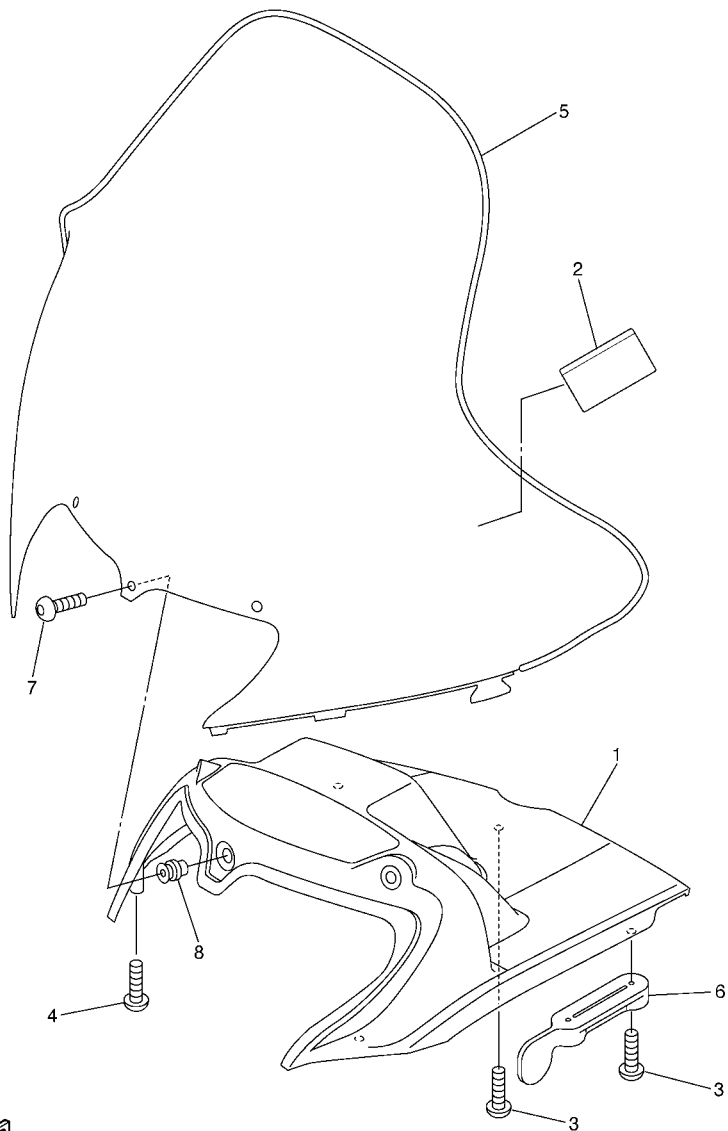

8FN1100-E340

REF. NO.	PART NO.	DESCRIPTION	8GSC	8GSD			REMARKS
1	8FN-77251-00	COVER, HEADLIGHT	1	1			
2	4B5-2815K-20	LABEL, NOTICE WINDSHIELD 1		1			FOR JPN
3	97702-50016	SCREW, TAPPING	3	3			
4	97702-50020	SCREW, TAPPING	2	2			
5	8FN-K7210-00	WINDSHIELD COMP.	1				
	8FN-77210-00	WINDSHIELD COMP.		1			
6	82H-77223-00	FASTNER	2	2			
7	90149-05299	SCREW	3	3			
8	90179-05523	NUT	3	3			
<hr/>							
<hr/>							
<hr/>							
<hr/>							
<hr/>							
<hr/>							
<hr/>							
<hr/>							

FIG. 36 GUARD & LUGGAGE BOX

REF. NO.	PART NO.	DESCRIPTION	8GSC	8GSD	REMARKS
1	8FN-28100-01	TOOL KIT	1	1	
2	8FA-77311-02	GUARD, DRIVE	1	1	
3	8CR-77338-00	STAY, BELT	2	2	
4	90267-48010	RIVET, BLIND (4.8X12 YELLOW)	7	7	
5	8FA-77373-00	PROTECTOR	1	1	
6	8CR-77384-01	PIN	1	1	
7	8FN-21973-00	HOOK	1	1	
8	8CR-77319-00	DAMPER 1	1	1	
9	90267-47195	RIVET, BLIND(4.7X16.4 YELLOW)	3	3	
10	8BD-77762-00	LABEL, WARNING 2	1		
	86D-77762-00	LABEL, WARNING 2	1		UR FOR EUR
	8AC-77762-R1	LABEL, WARNING 2	1		UR FOR RUS
	8BD-77762-21	LABEL, WARNING 2	1		UR FOR JPN
11	8GS-47578-00	LABEL 1	1	1	EXCEPT FOR JPN
12	8ES-1417E-00	LABEL, CAUTION	1	1	
13	8FN-77390-00	LUGGAGE BOX ASSY	1	1	
14	8FN-77133-00	LOUVER 3	2	2	
15	90183-05068	NUT, SPRING	4	4	
16	8FN-2414G-00	SEAL	1	1	
17	8ET-82917-00	SWITCH	1	1	
18	8FN-77262-00	LINING, SHROUD 2	1	1	
19	8FN-77263-00	LINING, SHROUD 3	1	1	
20	8FN-241A3-00	SEAL 3	1	1	
21	8FN-241A4-00	SEAL 4	1	1	
22	8FN-2196T-00	TRIM 1	2	2	
23	8FN-2478C-00	BAR, SEAT LEVER	1	1	
24	8FN-24723-00	DAMPER, SEAT	1	1	

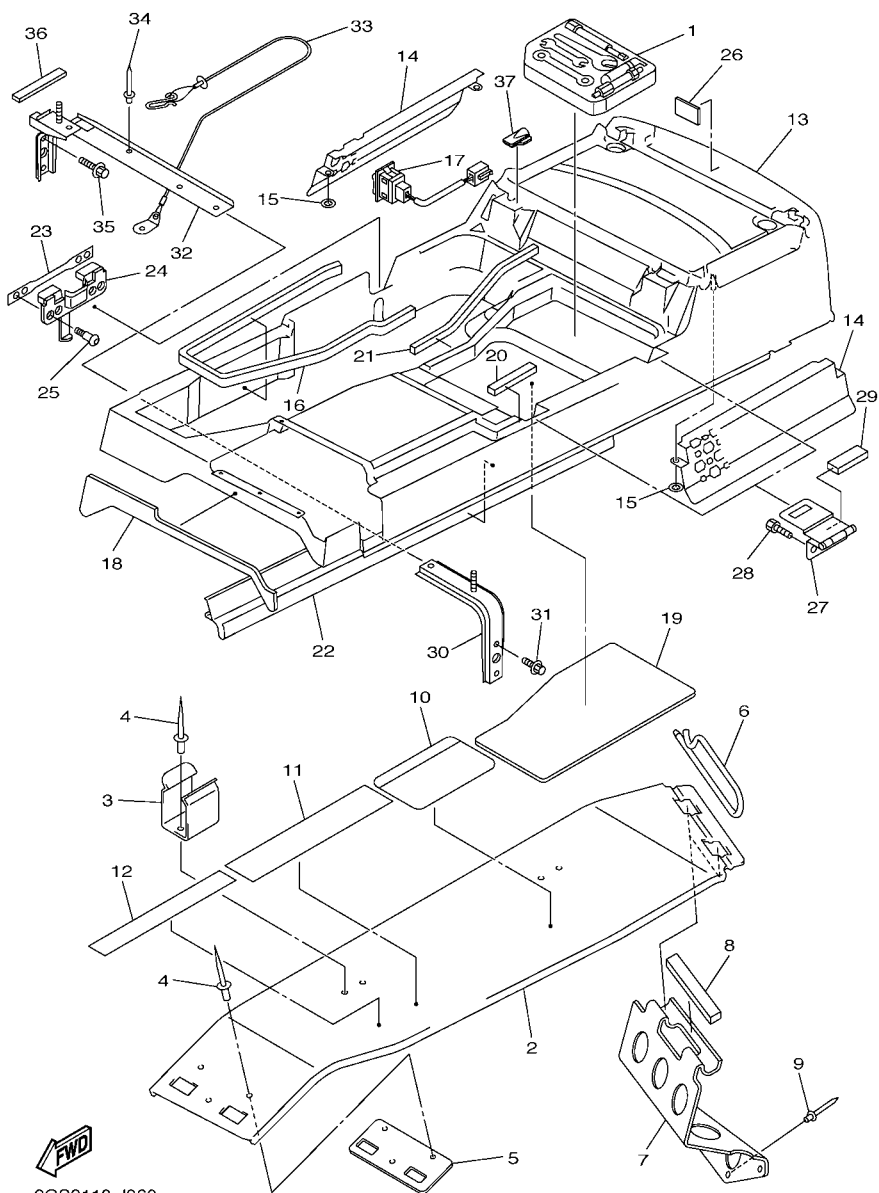

8GS9110-J360

FIG. 36 GUARD & LUGGAGE BOX

REF. NO.	PART NO.	DESCRIPTION	8GSC	8GSD	REMARKS
25	90111-05020	BOLT,HEX. SOCKET BUTTON	4	4	
26	5TG-84163-00	DAMPER	1	1	
27	8FN-24772-00	HINGE ASSY	2	2	
28	90110-06043	BOLT, HEXAGON SOCKET HEAD	4	4	
29	8FN-2414E-00	SEAL 2	2	2	
30	8FN-2194N-01	BRACKET, FUEL TANK 1	1	1	
31	95812-08014	BOLT, FLANGE	2	2	
32	8FN-2194R-01	BRACKET, FUEL TANK 2	1	1	
33	8FN-2478E-00	CABLE, SEAT LOCK	1	1	
34	90267-47186	RIVET, BLIND (4.7X16.4 BLACK)	1	1	
35	95812-08014	BOLT, FLANGE	3	3	
36	8FN-241A3-00	SEAL 3	1	1	
37	8FN-24742-00	GROMMET	1	1	

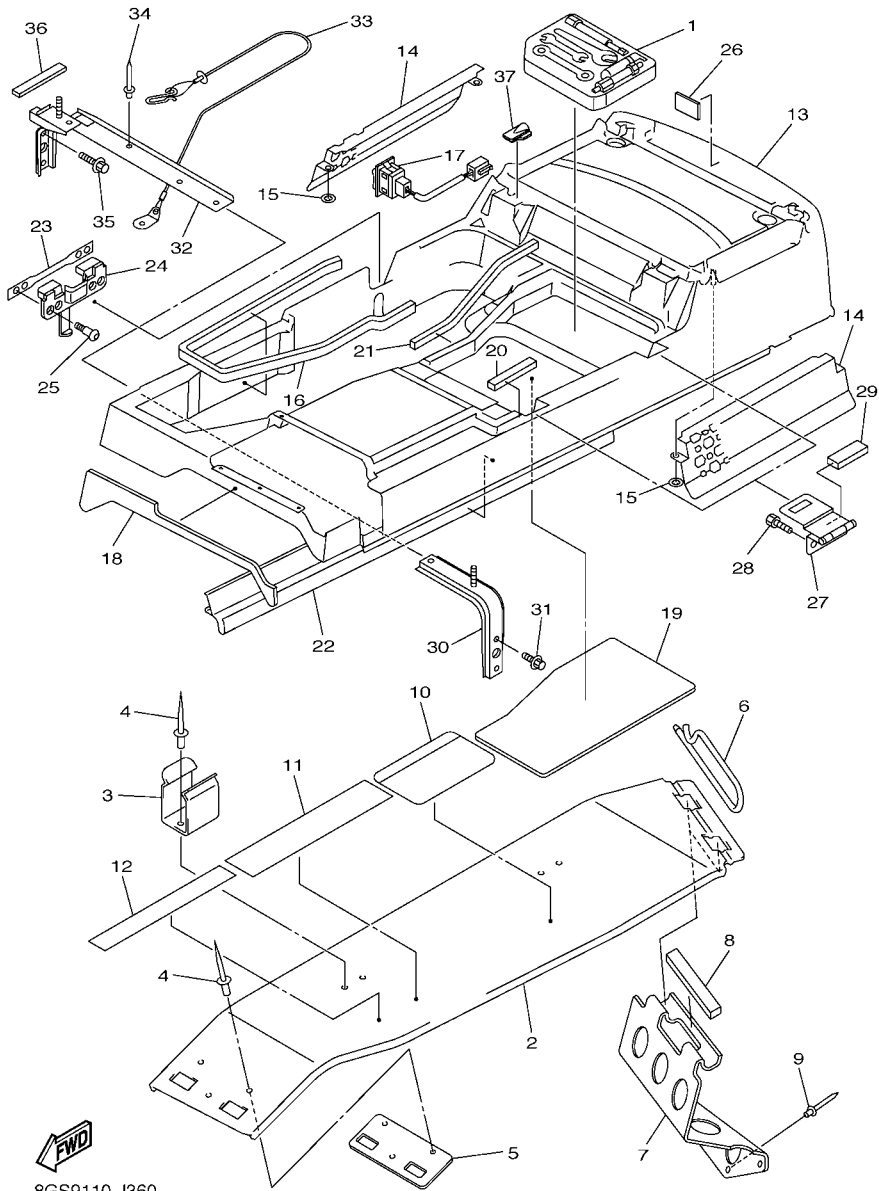

8GS9110-J360

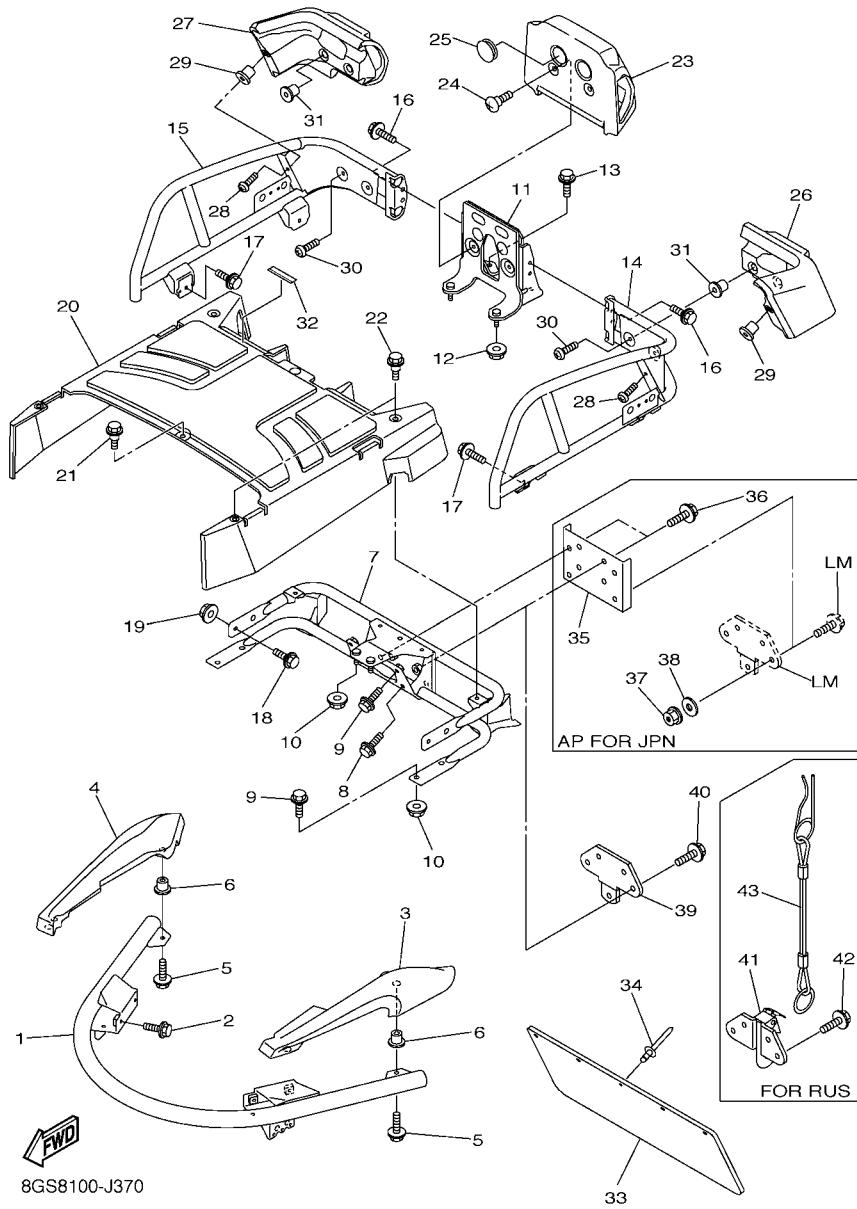

8GS8100-J370

FIG. 37 BUMPER

REF. NO.	PART NO.	DESCRIPTION	8GSC	8GSD	REMARKS
1	8FN-77511-10	BUMPER, FRONT 1	1	1	
2	95822-08020	BOLT, FLANGE	4	4	
3	8FN-77523-00	END, BUMPER	1	1	
4	8FN-77524-00	END, BUMPER	1	1	
5	95822-06020	BOLT, FLANGE	4	4	
6	90179-06520	NUT	4	4	
7	8FN-77541-00	BUMPER, REAR 1	1	1	
8	95822-10020	BOLT, FLANGE	2	2	
9	95822-08016	BOLT, FLANGE	6	6	
10	95702-08500	NUT, FLANGE	6	6	
11	8FN-77542-00	BUMPER, REAR 2	1	1	
12	95702-08500	NUT, FLANGE	2	2	
13	95812-08016	BOLT, FLANGE	2	2	
14	8FN-77543-10	BUMPER, REAR 3	1	1	
15	8FN-77544-10	BUMPER, REAR 4	1	1	
16	95822-08016	BOLT, FLANGE	4	4	
17	95822-10020	BOLT, FLANGE	4	4	
18	95802-06014	BOLT, FLANGE	2	2	
19	95702-06500	NUT, FLANGE	2	2	
20	8FN-77551-00	PROTECTOR 1	1	1	
21	90109-06272	BOLT	1	1	
22	90109-06172	BOLT	4	4	
23	8FN-77552-00	PROTECTOR 2	1	1	
24	90154-06009	SCREW, BINDING	2	2	
25	90338-28242	PLUG	2	2	
26	8FN-77553-00	PROTECTOR 3	1	1	
27	8FN-77554-00	PROTECTOR 4	1	1	

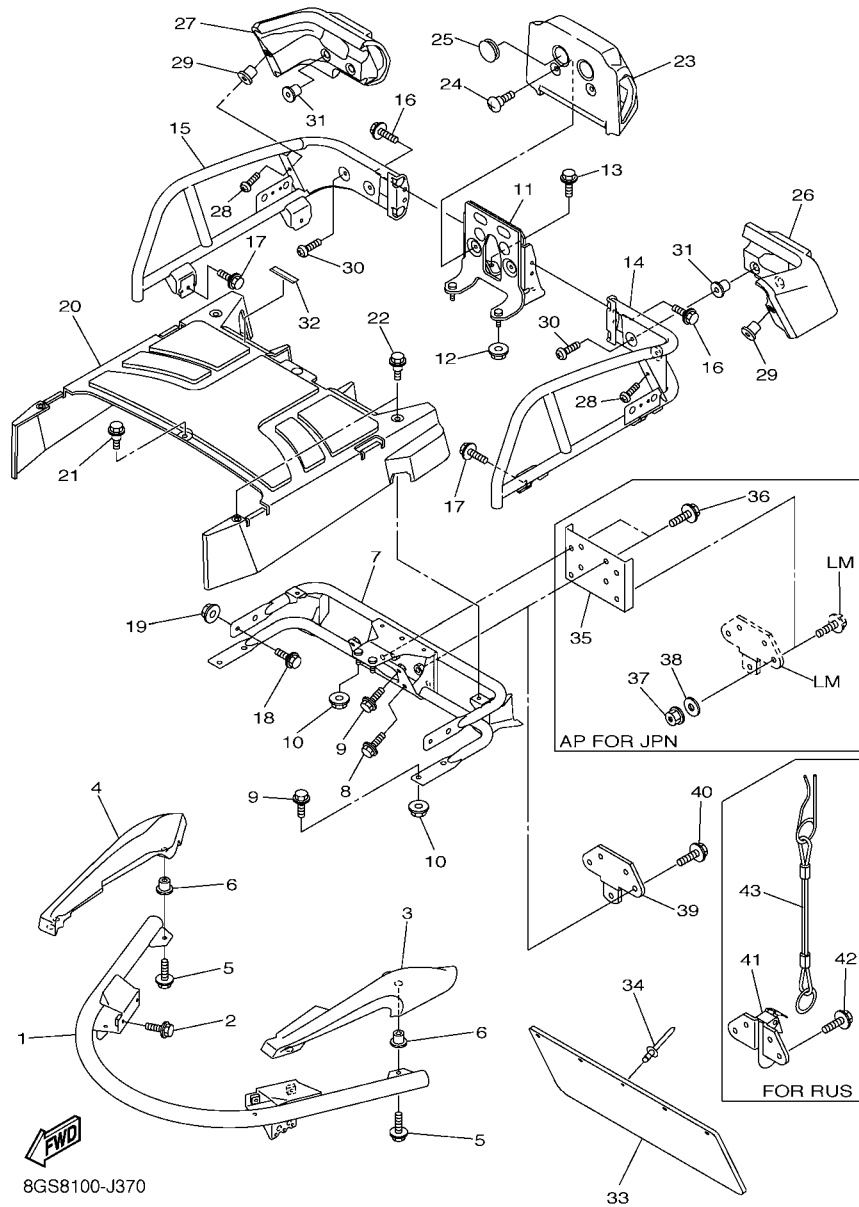
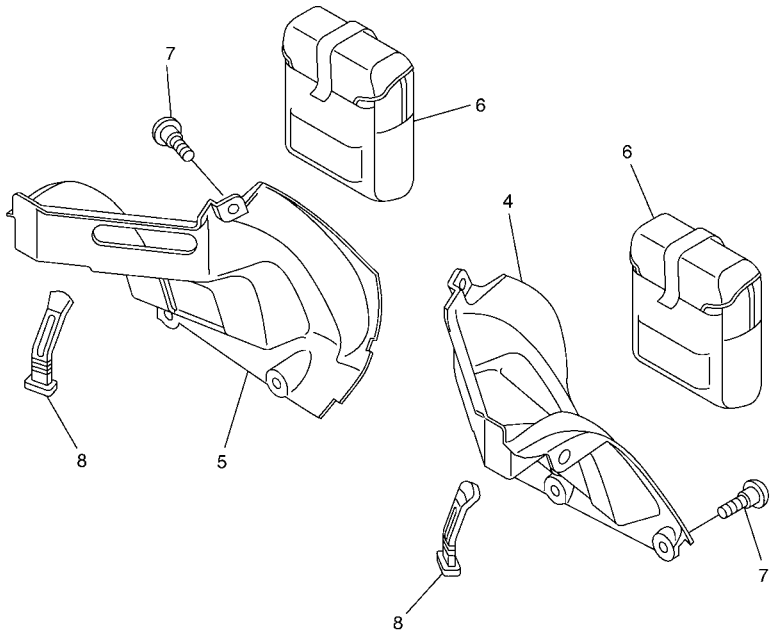
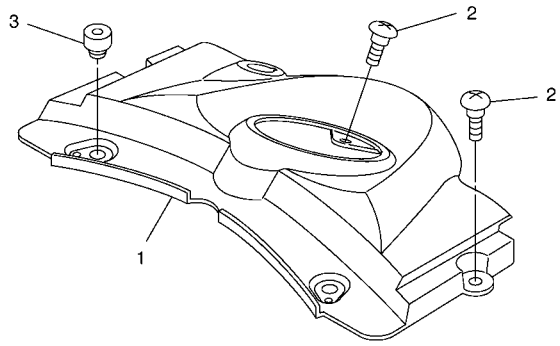

FIG. 37 BUMPER

REF. NO.	PART NO.	DESCRIPTION	8GSC	8GSD	REMARKS
28	98902-06016	SCREW, BIND	2	2	
29	90179-06520	NUT	2	2	
30	98902-08020	SCREW, BIND	4	4	
31	90179-08011	NUT	4	4	
32	8FM-24897-01	EMBLEM	1		
	8FM-24897-11	EMBLEM	1		UR FOR EUR,RUS
	4KN-24877-C0	LABEL, CAUTION	1		UR FOR JPN
33	83R-77595-00	FLAP	1	1	
34	90267-48086	RIVET, BLIND (4.8X19 BLACK)	5	5	
35	80M-77591-00	BRACKET, HITCH 1	1		AP FOR JPN
36	95822-08025	BOLT, FLANGE	4		AP FOR JPN
37	95712-08300	NUT, FLANGE	4		AP FOR JPN
38	92902-08600	WASHER, PLATE	4		AP FOR JPN
39	84R-77592-00	BRACKET, HITCH 2	1		
40	95822-08025	BOLT, FLANGE	4		
41	86D-77591-00	BRACKET, HITCH 1	1		FOR RUS
42	95822-08025	BOLT, FLANGE	4		FOR RUS
43	8U1-77157-00	PIN, HINGE	1		FOR RUS



8FN1100-E370

FIG. 38 INSTRUMENT PANEL

REF. NO.	PART NO.	DESCRIPTION	8GSC	8GSD		REMARKS
1	8FN-77711-00	PANEL, INSTRUMENT	1	1		
2	90149-06263	SCREW	3	3		
3	4N0-27114-00	STOPPER, MAIN STAND	2	2		
4	8FN-77131-00	LOUVER 1	1	1		
5	8FN-77132-00	LOUVER 2	1	1		
6	8GS-77735-00	BOX, GLOVE	2	2		
7	90154-06009	SCREW, BINDING	6	6		
8	8FA-77171-00	BODY, LATCH 1	2	2		

FIG. 39 GENERATOR

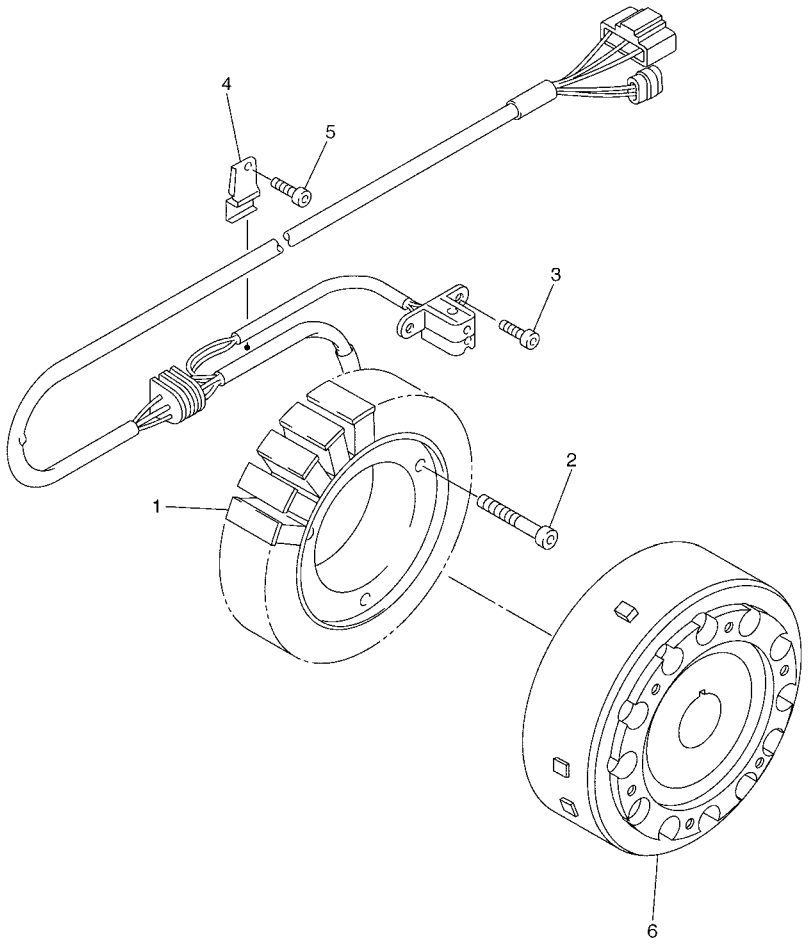

REF. NO.	PART NO.	DESCRIPTION	8GSC	8GSD			REMARKS
1	8ES-81410-00	STATOR ASSY	1	1			
2	90110-06223	BOLT, HEXAGON SOCKET HEAD	3	3			
3	90110-05034	BOLT, HEXAGON SOCKET HEAD	2	2			
4	8FA-15113-00	PLATE	1	1			
5	90110-06187	BOLT, HEXAGON SOCKET HEAD	1	1			
6	8ES-81450-01	ROTOR ASSY	1	1			

8ES1100-D370

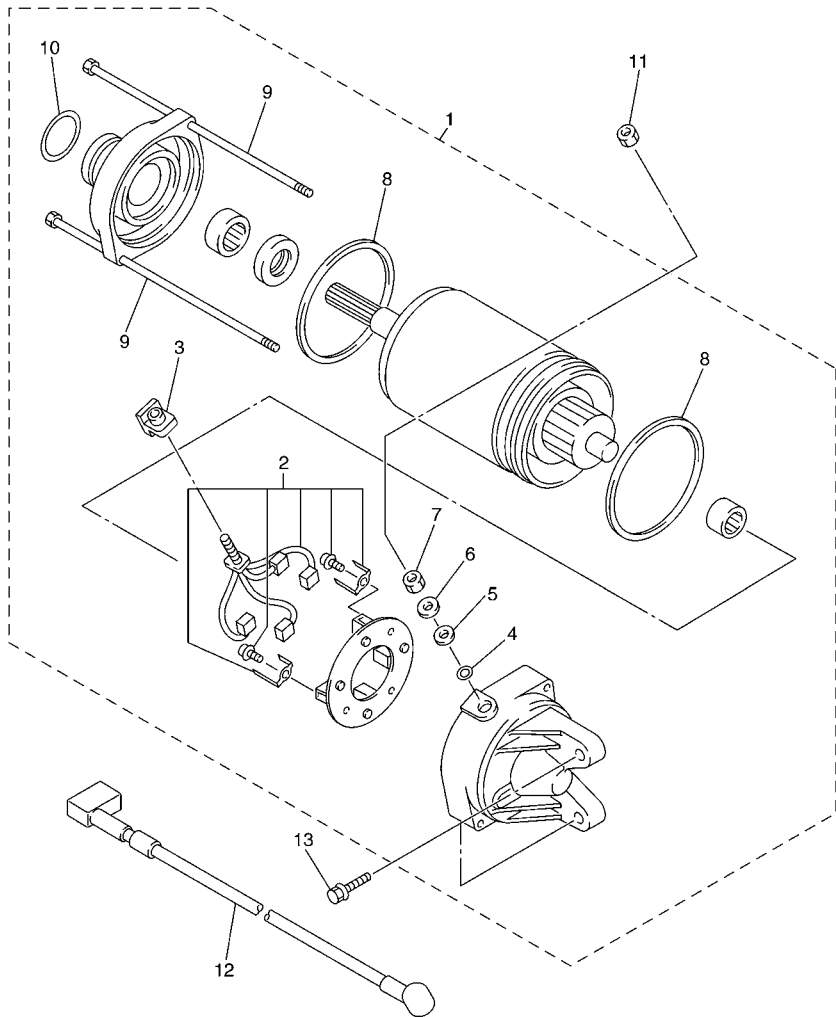
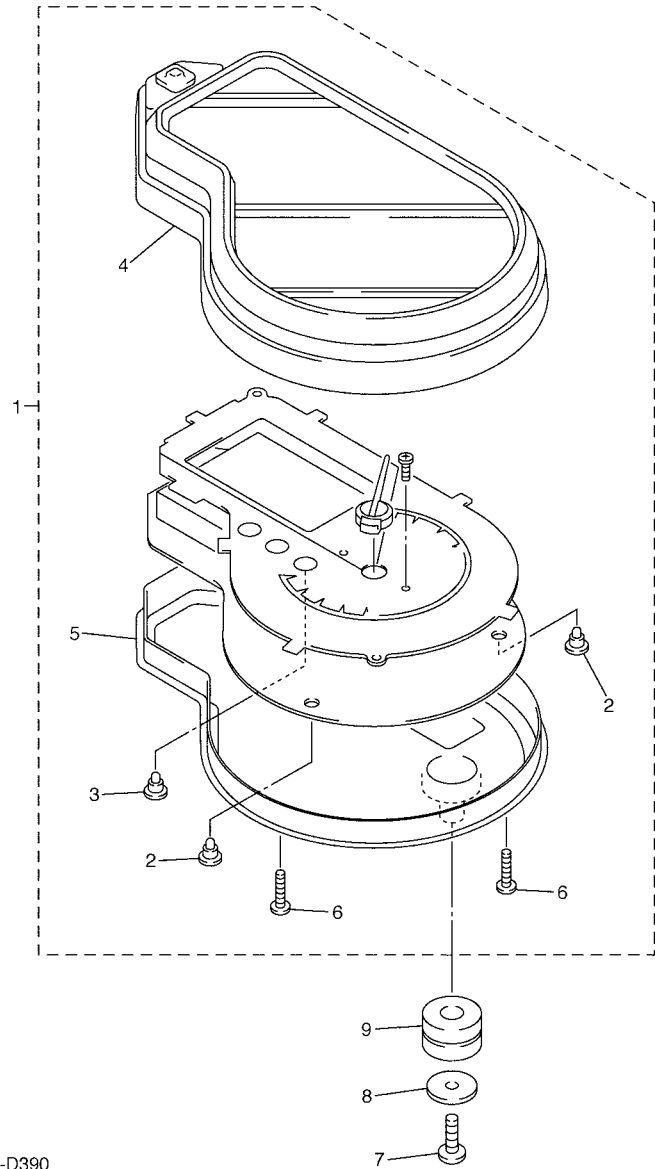

FIG. 40 STARTING MOTOR

REF. NO.	PART NO.	DESCRIPTION	8GSC	8GSD	REMARKS
1	8GL-81890-00	MOTOR ASSY	1	1	
2	2S3-81801-00	.BRUSH SET	1	1	
3	2S3-8182G-00	.BUSH, TERMINAL	1	1	
4	93210-06001	.O-RING	1	1	
5	8FA-8181L-00	.WASHER, PLAIN	1	1	
6	1D7-81835-00	.WASHER	1	1	
7	95302-06700	.NUT	1	1	
8	5PX-81861-00	.GASKET	2	2	
9	8ES-81846-01	.SCREW	2	2	
10	93210-24235	.O-RING	1	1	
11	95302-06700	NUT	1	1	
12	8ES-8183G-00	CORD COMP.	1	1	
13	95812-08030	BOLT, FLANGE	2	2	



8GS3100-G400



8ES1100-D390

FIG. 41 METER

REF. NO.	PART NO.	DESCRIPTION	8GSC	8GSD	REMARKS
1	8FN-83500-01	SPEEDOMETER ASSY (KM/H)	1	1	
2	4WM-83517-00	.BULB (T3 14V-50MA)	6	6	
3	4WM-83517-10	.BULB (T3.4 14V-80MA)	3	3	
4	8EK-8353E-01	.CASE, METER UPPER	1	1	
5	8EK-83572-01	.CASE, SPEEDOMETER LOWER	1	1	
6	5PW-8352S-00	.SCREW, PANEL FITTING	7	7	
7	97702-50016	SCREW, TAPPING	3	3	
8	90201-05725	WASHER, PLATE	3	3	
9	4XV-83513-00	DAMPER	3	3	

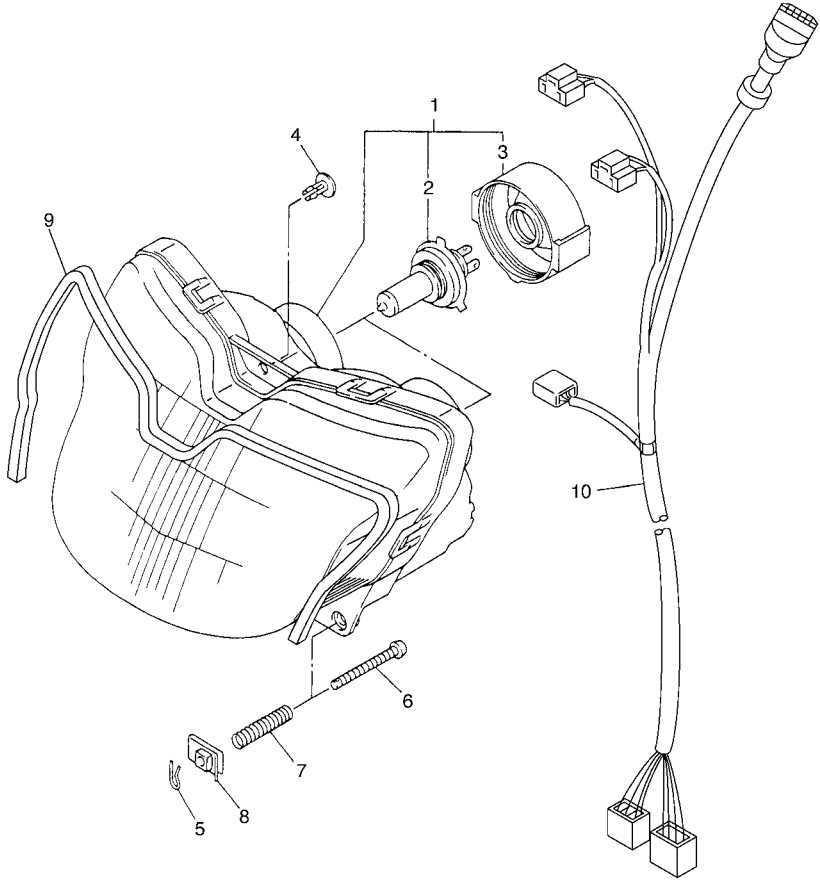

8FN1100-E410

FIG. 42 HEADLIGHT

REF. NO.	PART NO.	DESCRIPTION	8GSC	8GSD		REMARKS
1	8DN-84310-01	HEADLIGHT UNIT ASSY	1	1		
2	8G9-84314-00	.BULB (12V-60/55W)	2	2		(H4)HALOGEN
3	8DN-84397-01	.COVER, SOCKET	2	2		
4	90269-06046	RIVET	1	1		
5	8K4-84374-00	CLIP	2	2		
6	8A5-84331-00	SCREW, RIM ADJUSTING	2	2		
7	8A5-84332-00	SPRING, SCREW	2	2		
8	90183-05024	NUT, SPRING	2	2		
9	8FN-8399N-00	INSULATOR 1	1	1		
10	8FN-84359-00	CORD, HEADLIGHT	1	1		

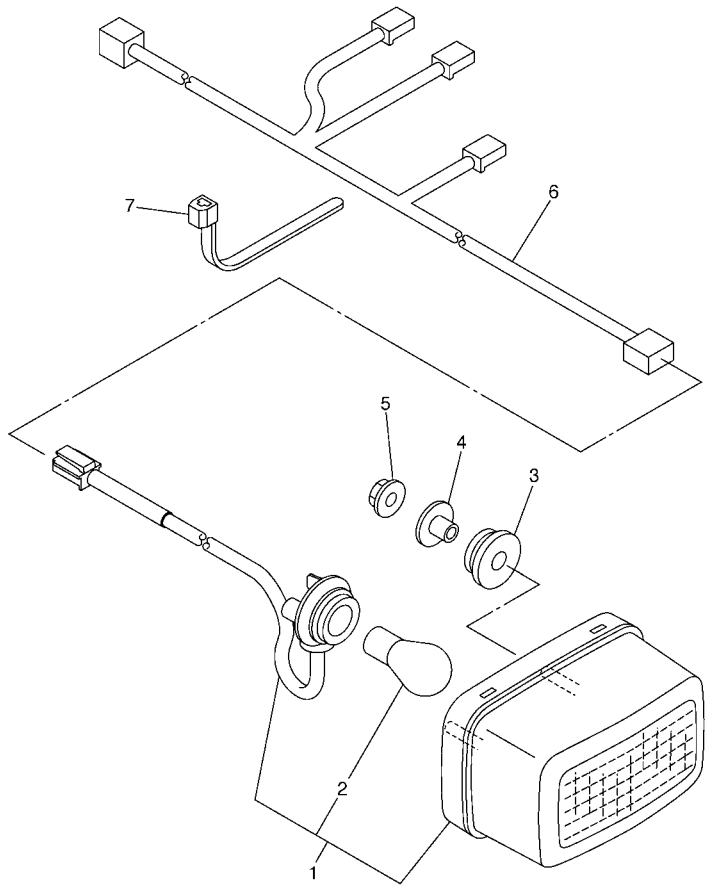

8FN1100-E420

FIG. 43 TAILLIGHT

REF. NO.	PART NO.	DESCRIPTION	8GSC	8GSD		REMARKS
1	8FN-84710-00	TAILLIGHT UNIT ASSY	1	1		
2	1A2-84714-41	.BULB (12V-21/5W)	1	1		
3	90480-18007	GROMMET	2	2		
4	90387-06033	COLLAR	2	2		
5	95702-06500	NUT, FLANGE	2	2		
6	8FN-84717-00	CORD, TAILLIGHT	1	1		
7	90464-25004	CLAMP	2	2		

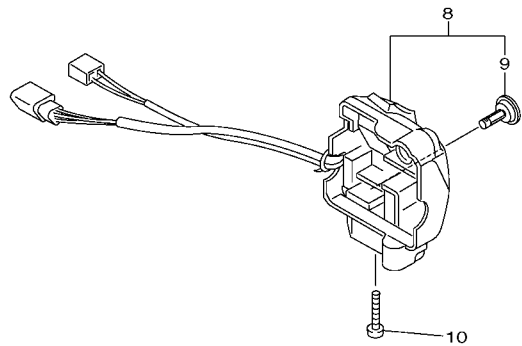
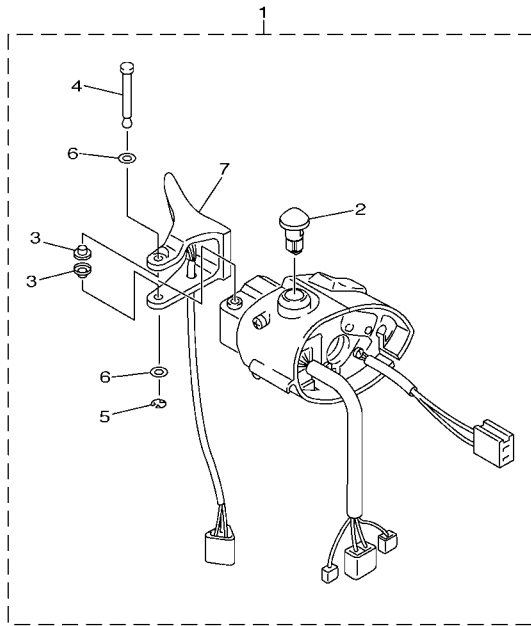

8GS9110-J440

FIG. 44 HANDLE SWITCH & LEVER

REF. NO.	PART NO.	DESCRIPTION	8GSC	8GSD	REMARKS
1	8ES-82720-02	LEVER HOLDER ASSY (RIGHT)	1	1	
2	8GL-86284-09	.STOP SWITCH	1	1	
3	85G-83956-00	.CAP 1	2	2	
4	8R6-8399F-00	.SHAFT	1	1	
5	99001-04600	.CIRCLIP	1	1	
6	8FP-82558-00	.WASHER	2	2	
7	8FA-82970-01	.THUMB WARMER ASSY	1	1	
8	8FA-83973-01	SWITCH, HANDLE 3	1	1	
9	8GL-82526-09	.SWITCH, LAMP	1	1	
10	98502-05016	SCREW, PAN HEAD	2	2	

FIG. 45 ELECTRICAL 1

REF. NO.	PART NO.	DESCRIPTION	8GSC	8GSD	REMARKS
1	8FN-82305-00	IGNITOR UNIT ASSY	1	1	
2	8ES-85991-00	BRACKET, UNIT	1	1	
3	95822-06016	BOLT, FLANGE	2	2	
4	95822-06010	BOLT, FLANGE	2	2	
5	8ES-82310-00	IGNITION COIL ASSY	3	3	
6	5JW-81960-00	RECTIFIER & REGULATOR ASSY	1	1	
7	90105-06185	BOLT, FLANGE	2	2	
8	8GS-82590-10	WIRE HARNESS ASSY	1	1	
9	5JJ-82151-20	.FUSE (20A-BL)	3	3	
10	5JJ-82151-30	.FUSE (10A-BL)	2	2	
11	5JJ-82151-10	.FUSE (15A-BL)	3	3	
12	5JJ-82151-50	.FUSE (3A-BL)	2	2	
13	90464-15195	CLAMP	6	6	
14	90464-13073	CLAMP	4	4	
15	90464-12045	CLAMP	1	1	
16	90464-13077	CLAMP	3	3	
17	90464-35132	CLAMP	1	1	
18	5DM-81950-00	RELAY ASSY (G8HN-1C4T-DJ-Y52)	2	2	
19	8DM-81950-11	RELAY ASSY	4	4	
20	8FJ-82510-00	MAIN SWITCH ASSY	1	1	
21	8GK-83755-11	SENSOR, SPEED	1	1	
22	95702-08300	NUT, NYLON	4	4	
23	8EK-47551-00	HOUSING, FRONT AXLE	1	1	
24	8GL-83383-00	BUZZER	1	1	
25	90159-05035	SCREW, WITH WASHER	1	1	
26	95702-05500	NUT, FLANGE	1	1	

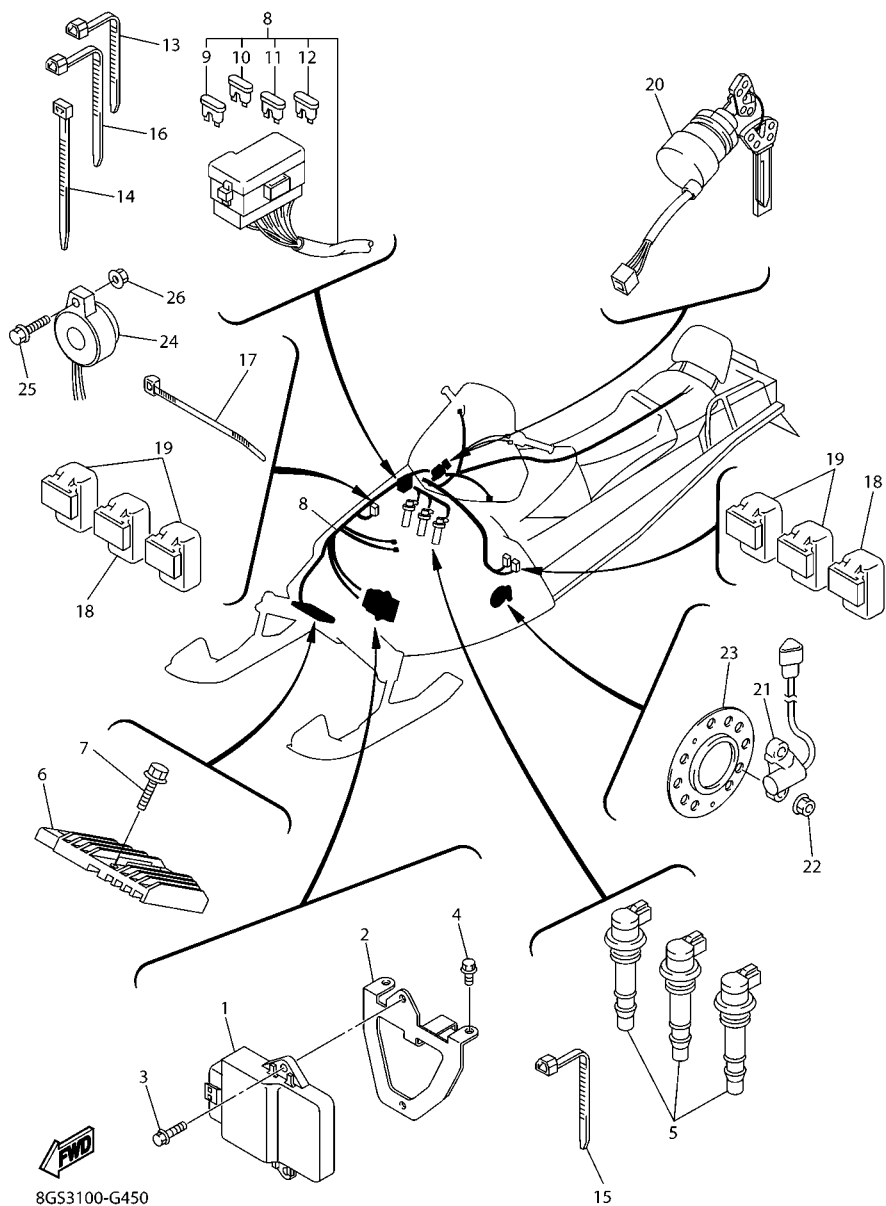

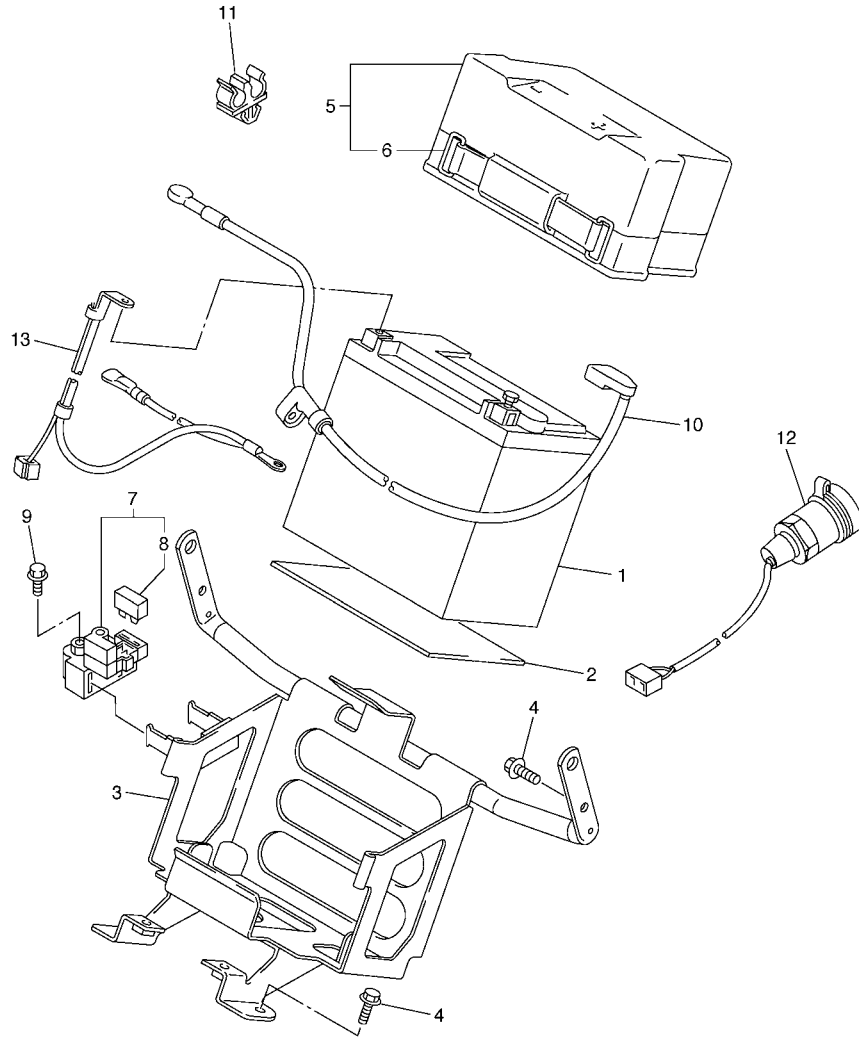

8FN1100-E450

FIG. 46 ELECTRICAL 2

REF. NO.	PART NO.	DESCRIPTION	8GSC	8GSD	REMARKS
1	4SH-82100-22	BATTERY ASSY (YUASA YTX20L-BS)	1	1	UR FOR EUR.RUS
	90793-26123	BATTERY ASSY (YTX20L-BS-GY)		1	UR FOR JPN
2	8FA-82122-00	SEAT, BATTERY	1	1	
3	8FN-2199G-00	BRACKET, BATTERY	1	1	
4	95822-08016	BOLT, FLANGE	4	4	
5	8FA-82129-00	COVER, BATTERY	1	1	
6	8DM-82131-10	.BAND, BATTERY	1	1	
7	4DN-81940-12	STARTER RELAY ASSY	1	1	
8	1AE-82151-00	.FUSE (30A-BL)	2	2	
9	95022-06008	BOLT, FLANGE	2	2	
10	8FN-82115-00	WIRE, PLUS LEAD	1	1	
11	90464-08126	CLAMP	1	1	
12	8FP-8254B-00	TERMINAL COMP.	1	1	
13	8FN-82116-00	WIRE, MINUS LEAD	1	1	

FIG. 47 ELECTRICAL 3

REF. NO.	PART NO.	DESCRIPTION	8GSC	8GSD				REMARKS
1	8GM-85110-00	REFLECTOR ASSY	2	2				
2	95702-05500	NUT, FLANGE	2	2				
3	3Y6-85130-02	REAR REFLECTOR ASSY	2	2				
4	90201-05036	WASHER, PLATE	2	2				
5	95702-05300	NUT, NYLON	2	2				
6	3Y6-85130-02	REAR REFLECTOR ASSY	2					
	8GM-85110-00	REFLECTOR ASSY		2				
7	95702-05500	NUT, FLANGE	2	2				

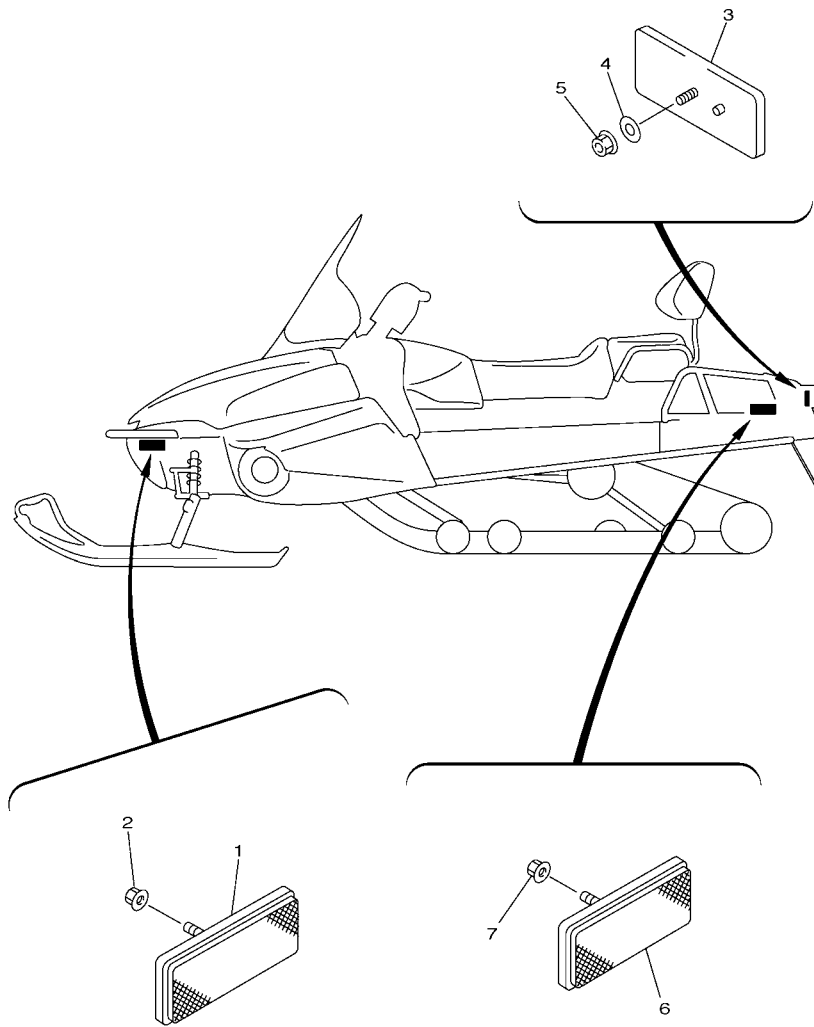

8GS9110-J470

FIG. 48 ELECTRICAL 4

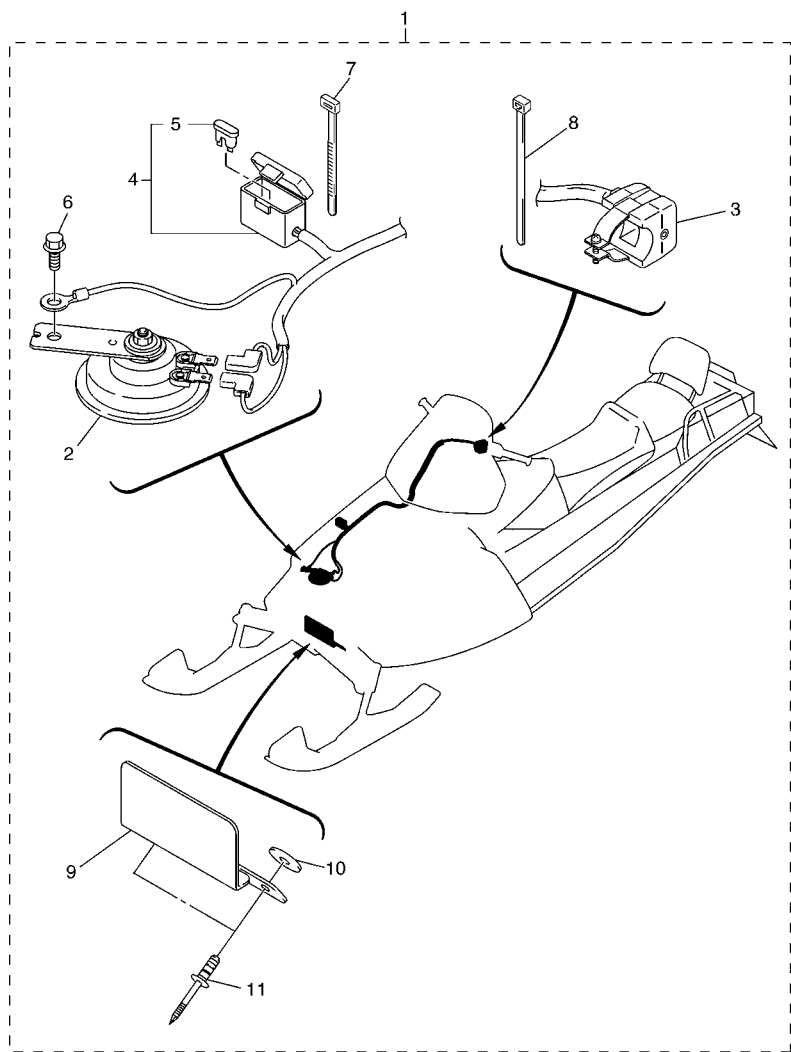

8GS3100-G480

REF. NO.	PART NO.	DESCRIPTION	8GSC	8GSD	REMARKS
1	8GS-833A0-00	HORN KIT		1	FOR FINLAND
2	3MX-83371-11	.HORN		1	FOR FINLAND
3	8FR-83976-02	.SWITCH, HANDLE 1		1	FOR FINLAND
4	8GS-82509-00	.WIRE, SUB LEAD		1	FOR FINLAND
5	5JJ-82151-50	..FUSE (3A-BL)		1	FOR FINLAND
6	95822-06016	.BOLT, FLANGE		1	FOR FINLAND
7	437-83936-01	.BAND, SWITCH CORD		2	FOR FINLAND
8	90465-13152	.CLAMP		1	FOR FINLAND
9	8GU-21641-00	.BRACKET, REFLECTOR		1	FOR FINLAND
10	90201-05036	.WASHER, PLATE		2	FOR FINLAND
11	90267-47186	.RIVET, BLIND (4.7X16.4 BLACK)		2	FOR FINLAND

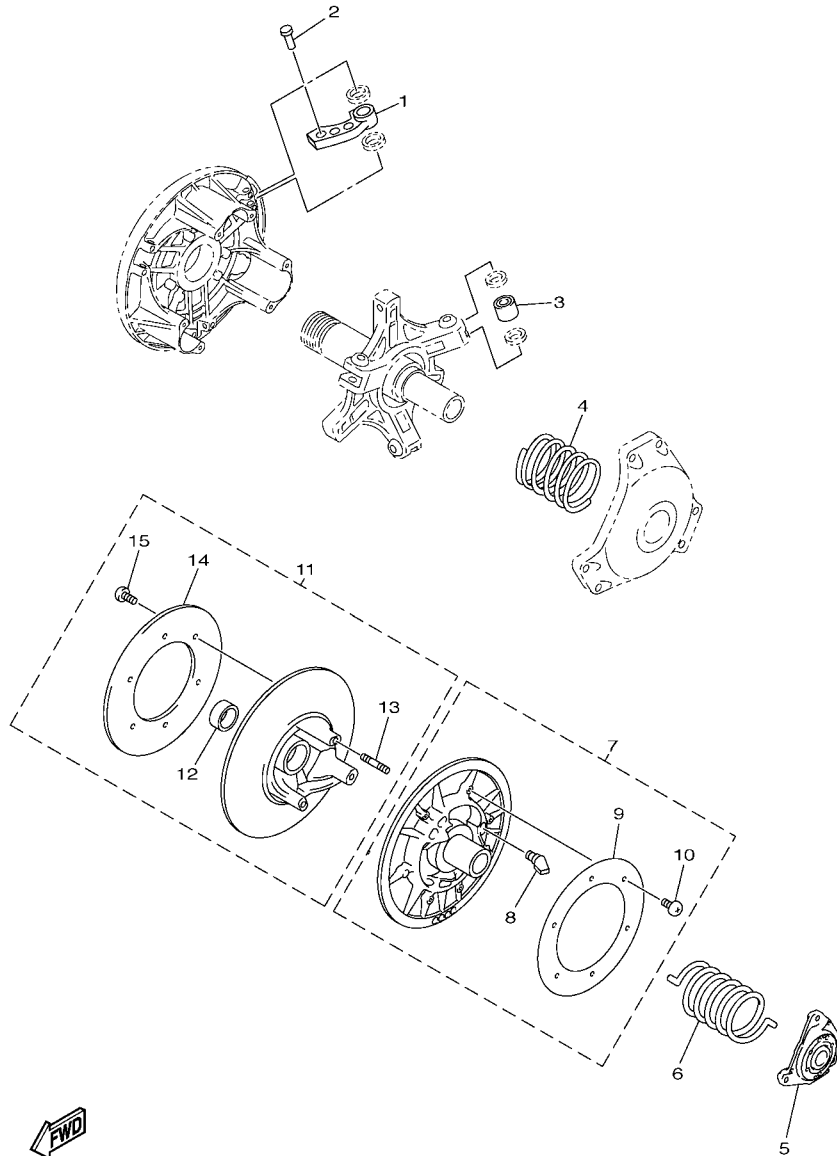

8HG1110-K490

FIG. 49 ALTERNATE DRIVE SETTING 1

REF. NO.	PART NO.	DESCRIPTION	8GSC	8GSD		REMARKS
1	8DN-17605-30	WEIGHT COMP	3	3		UR
	8ES-17605-00	WEIGHT COMP	3	3		UR
	8FA-17605-10	WEIGHT COMP	3	3		UR
	8FN-17605-00	WEIGHT COMP	3	3		UR
	8FP-17605-00	WEIGHT COMP	3	3		UR
	8FS-17605-00	WEIGHT COMP	3	3		UR
	8GC-17605-00	WEIGHT COMP	3	3		UR
	8GL-17605-00	WEIGHT COMP	3	3		UR
	8HF-17605-00	WEIGHT COMP	3	3		UR
	8HG-17605-00	WEIGHT COMP	3	3		UR
2	90261-06028	RIVET, COUNTERSUNK (AL10.3MM)	3	3		UR
	90266-06001	RIVET (AL13.3)	3	3		UR
	90261-06015	RIVET, COUNTERSUNK (ST10.3MM)	3	3		UR
	90266-06002	RIVET (ST13.3)	3	3		UR
	90261-06019	RIVET, COUNTERSUNK (ST13.3MM)	3	3		UR
	90261-06034	RIVET, COUNTERSUNK (ST13.9MM)	3	3		UR
	90269-06006	RIVET (ST17.2MM)	3	3		UR
	90261-06033	RIVET, COUNTERSUNK (ST17.2MM)	3	3		UR
3	8FG-17624-00	ROLLER, COMP	3	3		UR
	8FG-17624-10	ROLLER, COMP	3	3		UR
	8FG-17624-20	ROLLER, COMP	3	3		UR
	8FG-17624-30	ROLLER, COMP	3	3		UR
	8FG-17624-40	ROLLER, COMP	3	3		UR
4	90501-550A2	SPRING, COMPRESSION	1	1		UR (BL-BL-BL)
	90501-550A3	SPRING, COMPRESSION	1	1		UR (WH-BL-WH)
	90501-580A1	SPRING, COMPRESSION	1	1		UR (Y-BL-Y)
	90501-600A1	SPRING, COMPRESSION	1	1		UR (P-BL-P)

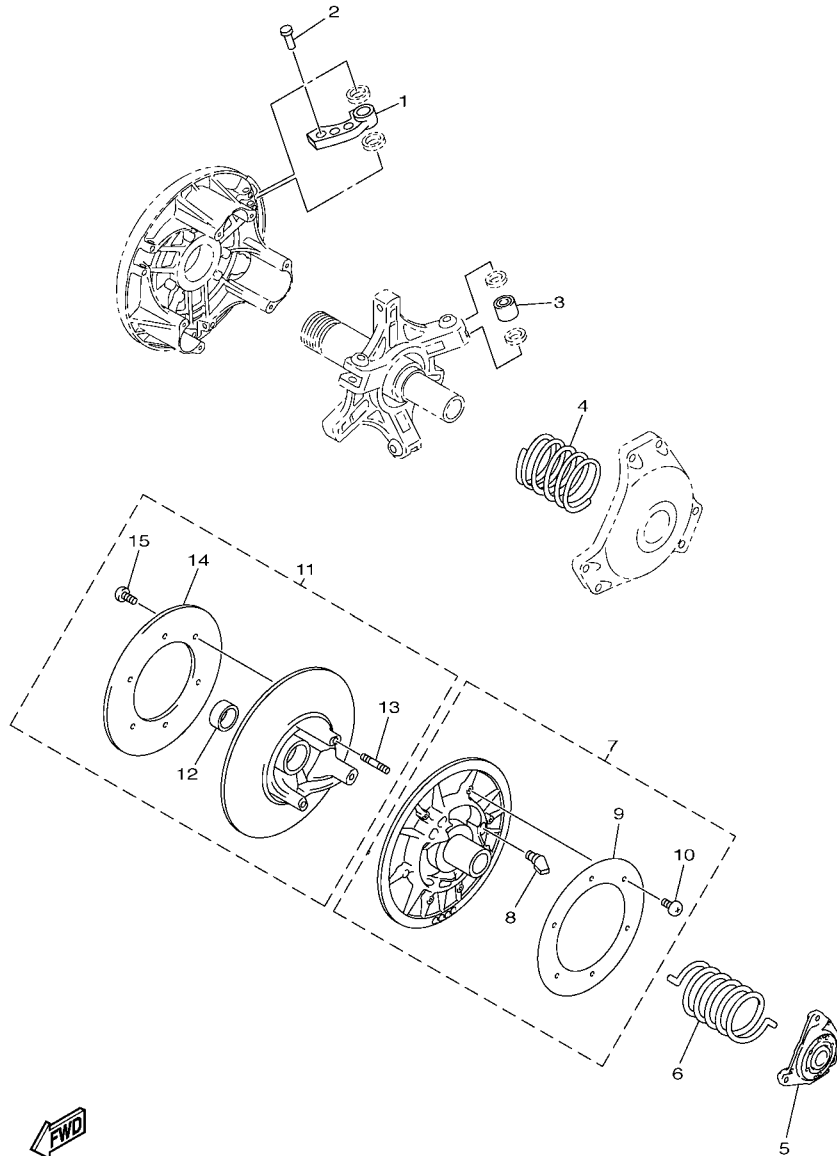

8HG1110-K490

FIG. 49 ALTERNATE DRIVE SETTING 1

REF. NO.	PART NO.	DESCRIPTION	8GSC	8GSD	REMARKS
4	90501-550A5	SPRING, COMPRESSION	1	1	UR (BL-Y-BL)
	90501-550A6	SPRING, COMPRESSION	1	1	UR (WH-Y-WH)
	90501-580A3	SPRING, COMPRESSION	1	1	UR (Y-Y-Y)
	90501-580A4	SPRING, COMPRESSION	1	1	UR (GR-Y-GR)
	90501-600A4	SPRING, COMPRESSION	1	1	UR (P-Y-P)
	90501-600A5	SPRING, COMPRESSION	1	1	UR (OR-Y-OR)
	90501-551L3	SPRING, COMPRESSION	1	1	UR (BL-P-BL)
	90501-583L5	SPRING, COMPRESSION	1	1	UR (WH-P-WH)
	90501-581L5	SPRING, COMPRESSION	1	1	UR (Y-P-Y)
	90501-581L6	SPRING, COMPRESSION	1	1	UR (GR-P-GR)
	90501-601L7	SPRING, COMPRESSION	1	1	UR (P-P-P)
	90501-601L8	SPRING, COMPRESSION	1	1	UR (OR-P-OR)
	90501-551L9	SPRING, COMPRESSION	1	1	UR (BL-SL-BL)
	90501-583L4	SPRING, COMPRESSION	1	1	UR (WH-SL-WH)
	90501-582L1	SPRING, COMPRESSION	1	1	UR (Y-SL-Y)
	90501-582L2	SPRING, COMPRESSION	1	1	UR (GR-SL-GR)
	90501-602L3	SPRING, COMPRESSION	1	1	UR (P-SL-P)
	90501-624L8	SPRING, COMPRESSION	1	1	UR (OR-SL-OR)
	90501-552L5	SPRING, COMPRESSION	1	1	UR (BL-GR-BL)
	90501-582L6	SPRING, COMPRESSION	1	1	UR (WH-GR-WH)
	90501-582L7	SPRING, COMPRESSION	1	1	UR (Y-GR-Y)
	90501-602L8	SPRING, COMPRESSION	1	1	UR (GR-GR-GR)
	90501-602L9	SPRING, COMPRESSION	1	1	UR (P-GR-P)
	90501-583L0	SPRING, COMPRESSION	1	1	UR (BL-WH-BL)
	90501-583L1	SPRING, COMPRESSION	1	1	UR (WH-WH-WH)
	90501-603L2	SPRING, COMPRESSION	1	1	UR (Y-WH-Y)
	90501-603L3	SPRING, COMPRESSION	1	1	UR (GR-WH-GR)

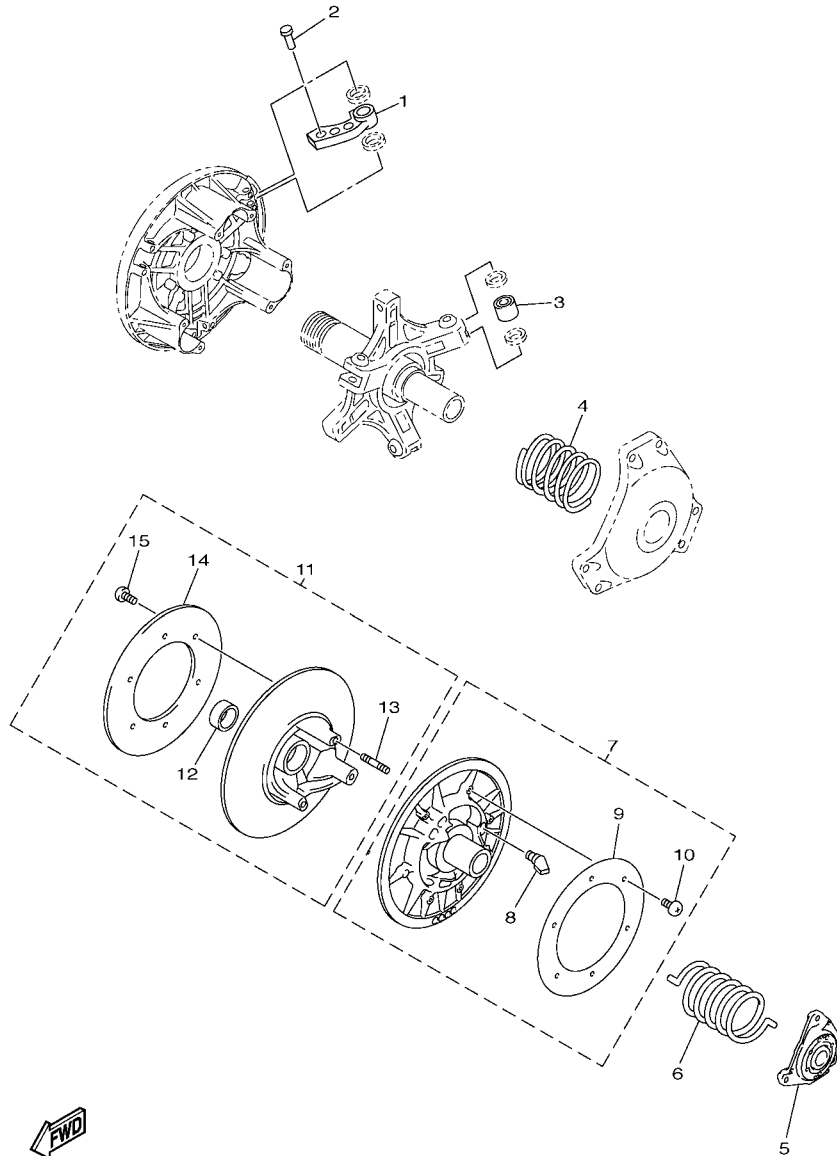

8HG1110-K490

FIG. 49 ALTERNATE DRIVE SETTING 1

REF. NO.	PART NO.	DESCRIPTION	8GSC	8GSD	REMARKS
4	90501-580A2	SPRING, COMPRESSION	1	1	UR (BL-BR-BL)
5	8BV-17604-11	SEAT SPRING SET	1	1	UR
	8BV-17604-31	SEAT SPRING SET	1	1	UR
	8BV-17604-51	SEAT SPRING SET	1	1	UR
	8BV-17604-71	SEAT SPRING SET	1	1	UR
	8BV-17604-91	SEAT SPRING SET	1	1	UR
	8FA-17604-00	SEAT SPRING SET	1	1	UR
6	90508-536A9	SPRING, TORSION	1	1	UR (RED)
	90508-556A2	SPRING, TORSION	1	1	UR (GREEN)
	90508-556A7	SPRING, TORSION	1	1	UR (SILVER)
	90508-500B1	SPRING, TORSION	1	1	UR (BROWN)
	90508-60007	SPRING, TORSION	1	1	UR (WHITE)
	90508-60016	SPRING, TORSION	1	1	UR (WH-WH)
	90508-60012	SPRING, TORSION	1	1	UR (PINK)
	90508-60018	SPRING, TORSION	1	1	UR (P-P)
7	8CR-17660-10	SECONDARY FIXED SHEAVE COMP.	1	1	UR
8	8AV-17688-10	.SHOE, RAMP	3	3	UR
9	8CM-17665-00	.PLATE 1	1	1	UR
10	90150-05040	.SCREW, ROUND HEAD	6	6	UR
11	8BU-17670-10	SECONDARY SLIDING SHEAVE	1	1	UR
12	90384-38243	.BUSH, BIMETAL FORMED	1	1	UR
13	95617-08630	.BOLT, STUD	3	3	UR
14	8CM-17675-00	.PLATE 2	1	1	UR
15	90150-05040	.SCREW, ROUND HEAD	6	6	UR

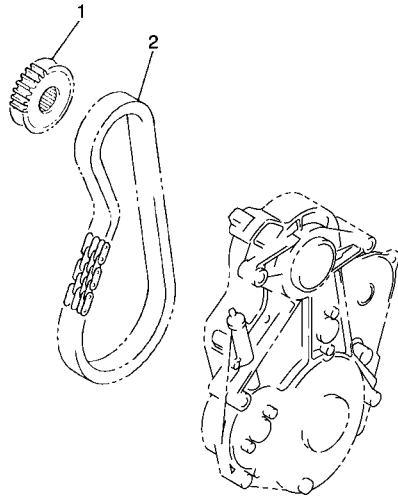

8GS1100-F490

FIG. 50 ALTERNATE DRIVE SETTING 2

REF. NO.	PART NO.	DESCRIPTION	8GSC	8GSD			REMARKS
1	8FA-17682-90	SPROCKET, CHAIN DRIVE (19T)	1	1			UR
	8FA-17682-00	SPROCKET, CHAIN DRIVE (20T)	1	1			UR
	8FA-17682-10	SPROCKET, CHAIN DRIVE (21T)	1	1			UR
	8FA-17682-20	SPROCKET, CHAIN DRIVE (22T)	1	1			UR
	8FA-17682-30	SPROCKET, CHAIN DRIVE (23T)	1	1			UR
	8FA-17682-40	SPROCKET, CHAIN DRIVE (24T)	1	1			UR
2	94890-09068	CHAIN (68L)	1	1			UR
	94890-09070	CHAIN (70L)	1	1			UR

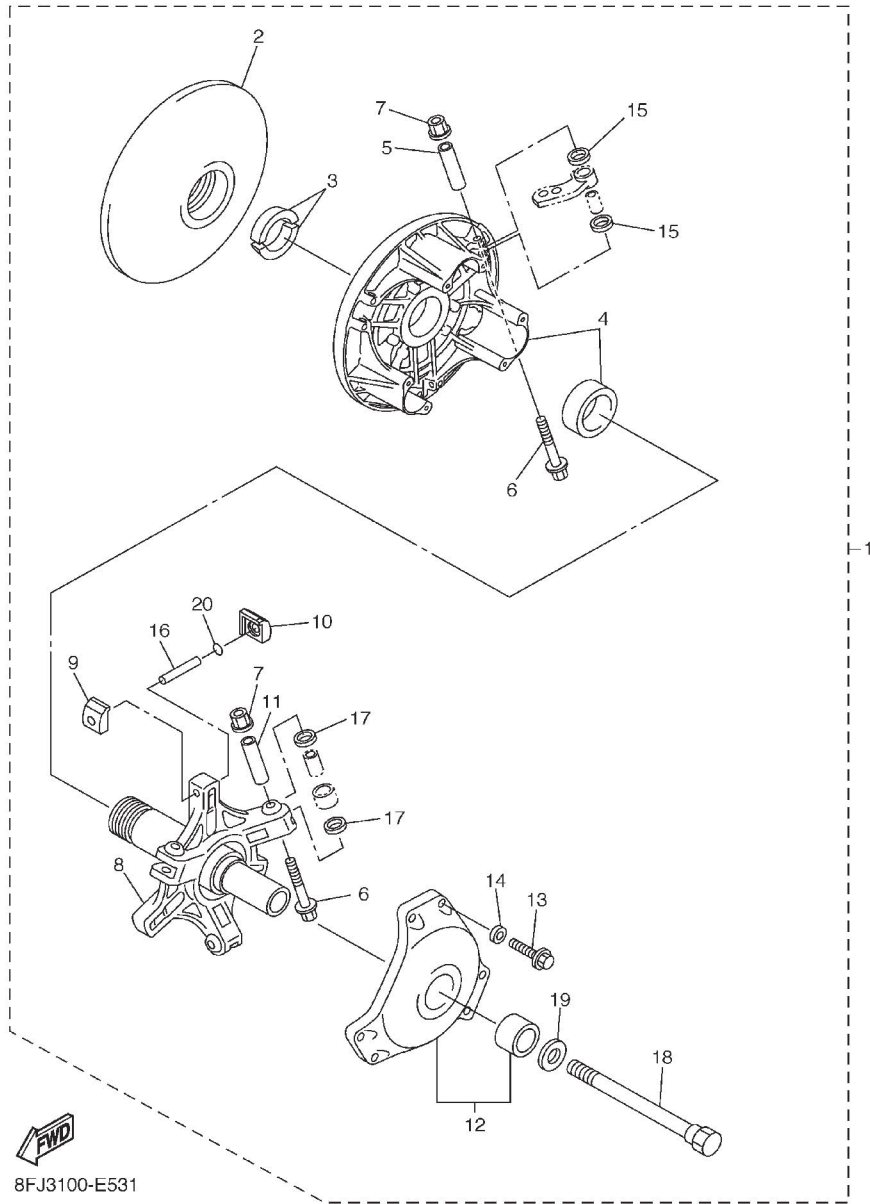

8FJ3100-E531

FIG. 51 ALTERNATE REBUILD KIT

REF. NO.	PART NO.	DESCRIPTION	8GSC	8GSD	REMARKS
1	8GS-W176G-02	CLUTCH REPAIR KIT	1	1	AP
2	8FA-17611-01	.SHEAVE, PRIMARY FIXED	1	1	
3	8V0-17639-00	.STOPPER	2	2	
4	8FP-17620-00	.PRIMARY SLIDING SHEAVE COMP.	1	1	
5	90387-0514T	.COLLAR	3	3	
6	90105-05644	.BOLT, FLANGE	6	6	
7	95607-05200	.NUT, U FLANGE	6	6	
8	8GS-17640-02	.SPIDER COMPLETE	1	1	
9	8BW-17653-00	.SLIDER	3	3	
10	8ES-17653-00	.SLIDER	3	3	
11	90387-0514U	.COLLAR	3	3	
12	8DF-17630-00	.PRIMARY SHEAVE CAP COMP.	1	1	
13	97017-06030	.BOLT	6	6	
14	92907-06600	.WASHER, PLATE	6	6	
15	90202-08204	.WASHER, PLATE	6	6	
16	91609-50032	.PIN, SPRING	3	3	
17	90202-09227	.WASHER, PLATE	6	6	
18	8V0-17647-00	.BOLT (L=156.5MM)	1	1	
19	92907-16100	.WASHER	1	1	
20	8ES-17655-00	.DAMPER, SLIDER	3	3	

FIG. 52 ALTERNATE CLUTCH TUNE UP KIT

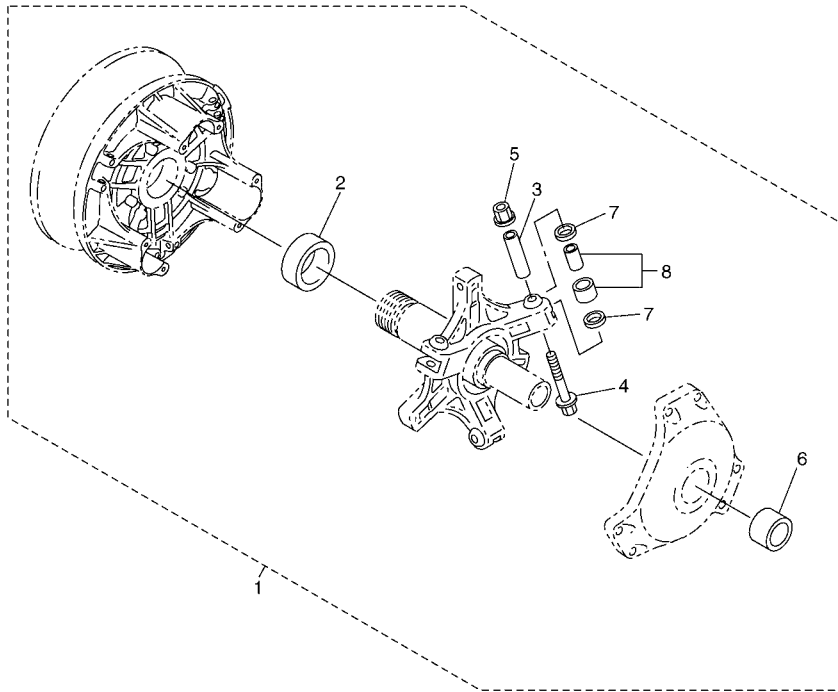

REF. NO.	PART NO.	DESCRIPTION	8GSC	8GSD			REMARKS
1	8FA-W176H-10	CLUTCH TUNE-UP KIT	1	1			AP
2	90384-41242	.BUSH, BIMETAL FORMED	1	1			
3	90387-0514U	.COLLAR	3	3			
4	90105-05644	.BOLT, FLANGE	3	3			
5	95607-05200	.NUT, U FLANGE	3	3			
6	90380-28237	.BUSH, SOLID	1	1			
7	90202-09227	.WASHER, PLATE	6	6			
8	8FG-17624-20	.ROLLER, COMP	3	3			



8FA1100-B550

NUMERICAL INDEX

PART NO.	REF. NO.	PART NO.	REF. NO.	PART NO.	REF. NO.	PART NO.	REF. NO.	PART NO.	REF. NO.	PART NO.	REF. NO.
8ES-11101-02	1 - 1	3LD-12168-A0	3 - 8	8FN-1244J-00	6 - 74	4JH-14121-00	10 - 27	8FA-14623-10	11 - 4	8GL-15590-00	14 - 4
4KG-1111G-00	1 - 17	3LD-12168-F0	3 - 8	8ES-12450-01	5 - 7	8ES-14121-00	10 - 51	8ES-14627-00	11 - 7	8ES-16775-00	2 - 18
5JW-11133-10	1 - 2	3LD-12168-H1	3 - 8	8ES-12459-01	5 - 9	4YR-14133-00	10 - 38	8FN-14637-00	11 - 9	8GS-17110-01	31 - 83
3P6-11134-10	1 - 3	3LD-12168-K1	3 - 8	8FN-12460-00	6 - 42	8ES-14146-00	22 - 13	8ES-14708-02	11 - 23	8GS-17111-00	31 - 60
8ES-11181-00	1 - 18	3LD-12168-M1	3 - 8	3LD-12168-00	6 - 73	8ES-14147-00	10 - 6	8FA-14714-10	11 - 16	8GS-1714A-01	31 - 70
8ES-11191-01	1 - 11	3LD-12168-R1	3 - 8	3XP-12462-00	6 - 47	8ES-14148-00	9 - 29	8FA-14715-00	11 - 3	8GS-17210-00	31 - 81
8ES-11193-00	1 - 13	3LD-12168-U1	3 - 8	8FN-12464-00	6 - 88	8ES-1414G-00	10 - 16	8FA-14737-00	11 - 20	8GS-17243-01	31 - 76
8ES-11400-02	2 - 1	3LD-12168-W1	3 - 8	8FN-12467-00	6 - 57	8ES-14162-00	10 - 33	8FN-14750-00	11 - 19	8CW-17492-00	31 - 77
8ES-11406-02	2 - 16	3LD-12168-Y1	3 - 8	8FN-12469-00	6 - 77	8ES-1417E-00	36 - 12	8FA-14788-00	11 - 17	8FA-17604-00	49 - 5
8ES-11407-02	2 - 22	3LD-12169-11	3 - 8	8FN-12477-02	6 - 62	3TJ-14191-40	10 - 22	8ES-1478N-00	11 - 26	8BV-17604-11	49 - 5
3LD-11416-10	2 - 6	3LD-12169-31	3 - 8	8ES-12482-00	6 - 1	8ES-14197-01	10 - 43	8ES-14900-02	10 - 1	8BV-17604-31	49 - 5
3LD-11416-20	2 - 6	3LD-12169-50	3 - 8	8ES-12485-01	6 - 2	4JH-14216-00	10 - 10	8ES-14901-01	10 - 2	8BV-17604-51	49 - 5
3LD-11416-30	2 - 6	3LD-12169-70	3 - 8	4TV-12486-00	10 - 50	8ES-14902-01	10 - 10	8ES-14902-01	10 - 3	8BV-17604-71	49 - 5
3LD-11416-40	2 - 6	3LD-12169-90	3 - 8	8FN-1248A-00	6 - 65	4YR-14216-00	10 - 47	8ES-14903-01	10 - 4	8BV-17604-91	16 - 11
3LD-11416-50	2 - 6	3LD-12169-E0	3 - 8	8FN-1248E-00	6 - 68	4JH-14264-00	10 - 31	8ES-14916-00	10 - 14		49 - 5
3LD-11416-60	2 - 6	3LD-12169-G0	3 - 8	8FW-1249A-00	6 - 9	8ES-14283-00	9 - 26	4TV-14926-00	10 - 26	8ES-17605-00	49 - 1
3LD-11416-70	2 - 6	3LD-12169-J0	3 - 8	8FN-12577-00	6 - 4	8ES-14294-00	9 - 4	8ES-14926-01	10 - 24	8FN-17605-00	15 - 25
8ES-11428-01	2 - 29	3LD-12169-L0	3 - 8	8ES-12578-00	6 - 17	8ES-14294-10	9 - 4	8ES-14933-00	10 - 11		49 - 1
8ES-11454-00	2 - 25	3LD-12169-N0	3 - 8	8FN-12579-00	6 - 11	8ES-14295-00	10 - 40	4YR-14934-00	10 - 52	8FP-17605-00	49 - 1
59J-11455-00	2 - 15	3LD-12169-T0	3 - 8	8FN-12580-00	6 - 24	8ES-14298-00	9 - 6	8ES-14935-00	10 - 32	8FS-17605-00	49 - 1
8ES-11464-00	2 - 32	8ES-12170-01	4 - 1	8ES-12588-00	6 - 19	8ES-14298-10	9 - 6	4JH-14936-00	10 - 13	8GC-17605-00	49 - 1
8ES-11478-00	2 - 30	8ES-12176-00	4 - 2	8FN-12589-00	6 - 21	4JH-14358-00	10 - 34	3TJ-14937-40	10 - 44	8GL-17605-00	49 - 1
8ES-11530-00	2 - 23	8ES-12210-01	4 - 5	8FN-12590-00	6 - 46	8ES-14419-00	9 - 23	8ES-14940-00	10 - 12	8HF-17605-00	49 - 1
5JW-11603-00	2 - 8	4FM-12213-00	4 - 6	8ES-13115-00	7 - 15	8ES-1441A-00	9 - 22	3TJ-14943-36	10 - 17	8HG-17605-00	49 - 1
8ES-11631-00	2 - 7	5BE-12241-00	1 - 12	8FN-1319B-02	7 - 13	8ES-14425-00	9 - 20	3TJ-14943-37	10 - 17	8FA-17605-10	49 - 1
5JW-11633-00	2 - 10	8ES-12251-00	4 - 8	8ES-13284-00	7 - 5	8ES-14427-00	9 - 31	3TJ-14943-87	10 - 17	8DN-17605-30	49 - 1
5JW-11650-01	2 - 2	8ES-12252-00	4 - 9	8ES-13300-00	7 - 1	8ES-14431-00	9 - 15	8ES-14947-00	10 - 15	8FA-17611-01	15 - 1
5JW-11654-00	2 - 3	8FP-12405-00	6 - 72	4XV-13355-00	7 - 2	8FA-14436-00	9 - 19	8ES-14948-03	10 - 18		51 - 2
5JW-11656-00	2 - 5	8FN-12405-01	6 - 43	8FG-13406-00	18 - 2	8ES-14441-00	9 - 16	8ES-14948-05	10 - 18	8GS-1761A-00	31 - 15
5JW-11656-10	2 - 5	8FN-12410-00	6 - 26	8ES-13414-01	8 - 4	8ES-14451-00	9 - 18	8ES-14948-06	10 - 18	8GS-1761E-00	31 - 18
5JW-11656-20	2 - 5	8EK-12412-00	6 - 27	8ES-13416-00	1 - 20	8ES-14452-00	9 - 21	8ES-14948-07	10 - 18	8FP-17620-00	15 - 3
5JW-11656-30	2 - 5	5EB-12413-00	6 - 25	8ES-13417-00	8 - 2	8ES-14453-00	9 - 24	8ES-14958-00	10 - 9		51 - 4
5JW-11656-40	2 - 5	8ES-12420-02	5 - 1	8ES-13427-00	7 - 4	8ES-14454-00	10 - 48	8ES-14965-00	10 - 35	8FG-17624-00	49 - 3
5JW-11656-A0	2 - 5	8ES-12422-00	5 - 2	5DM-13440-00	8 - 1	8FN-14472-00	9 - 17	8ES-14984-00	10 - 21	8FG-17624-10	49 - 3
5JW-12111-00	3 - 1	8ES-12427-00	5 - 3	8FN-13464-00	7 - 10	4JH-14487-00	10 - 39	8ES-14985-00	10 - 20	8FG-17624-20	15 - 22
5JW-12113-00	3 - 4	8ES-12434-00	5 - 13	8ES-13470-01	8 - 9	4TV-14534-00	10 - 56	8ES-14987-00	10 - 49		49 - 3
5JW-12116-00	3 - 3	8ES-12435-00	5 - 12	5JW-13473-00	8 - 10	676-14548-00	10 - 19	8ES-15100-08	12 - 1		52 - 8
5JW-12117-00	3 - 5	8ES-12436-00	5 - 17	8FN-13520-00	18 - 13	7A9-14555-00	10 - 28	8FA-15113-00	39 - 4	8FG-17624-30	49 - 3
1AA-12118-00	3 - 6	8ES-12438-00	5 - 4	8ES-13586-10	9 - 1	4YR-14557-00	10 - 57	8ES-15167-00	12 - 3	8FG-17624-40	49 - 3
5JW-12121-01	3 - 2	8FN-1243A-00	6 - 75	8ES-13815-00	10 - 41	8ES-14561-00	10 - 29	8ES-1531A-00	13 - 12	8DF-17630-00	15 - 17
3P6-12129-00	3 - 7	8FN-1243E-00	6 - 6	8ES-13816-00	10 - 42	4TV-14562-00	10 - 46	3Y1-15361-00	31 - 39		51 - 12
5EB-12153-09	3 - 9	8FN-1243F-00	6 - 76	8ES-13892-00	9 - 12	8ES-14565-00	10 - 30	3Y1-15363-10	1 - 14	8V0-17639-00	15 - 2
5EB-12153-10	3 - 9	8FN-12440-00	19 - 55	8ES-13895-00	9 - 10	8ES-14567-00	10 - 37	4JT-15381-01	2 - 26		51 - 3
3LD-12168-00	3 - 8	8FN-12443-00	9 - 37	8ES-13898-00	7 - 19	8ES-14578-00	10 - 36	8ES-15421-01	13 - 1	8GS-17640-02	15 - 9
3LD-12168-20	3 - 8	8FN-1244E-00	6 - 52	8FA-13910-00	9 - 32	8ES-14592-00	10 - 25	8ES-15461-01	13 - 6		51 - 8
3LD-12168-40	3 - 8	8FN-1244F-00	6 - 87	8ES-146105-00	10 - 5	8ES-14610-00	11 - 13	8ES-15512-01	14 - 2	8GS-17641-00	15 - 30
3LD-12168-60	3 - 8	8FN-1244G-00	6 - 40	8ES-14107-00	10 - 8	8ES-14613-00	11 - 2	8FA-15515-00	14 - 1	8V0-17647-00	15 - 31
3LD-12168-80	3 - 8	8FN-1244H-00	6 - 48	8ES-1410A-00	10 - 7	8ES-14615-01	11 - 1	8ES-15521-00	14 - 3		51 - 18

NUMERICAL INDEX

PART NO.	REF. NO.	PART NO.	REF. NO.	PART NO.	REF. NO.	PART NO.	REF. NO.	PART NO.	REF. NO.	PART NO.	REF. NO.	PART NO.	REF. NO.
8BW-17653-00	15 - 10	8ES-2174N-00	18 - 16	8FG-2197M-00	19 - 40	8FN-23828-00	21 - 29	8FA-24335-00	23 - 8	8GS-2815J-E0	9 - 30	8GS-2815J-J0	9 - 30
	51 - 9	8FG-21751-02	18 - 1	8FN-2198E-00	19 - 15	8FS-23829-00	21 - 2	8FA-24491-00	9 - 33	8GS-2815J-S0	9 - 30	8ET-2815K-00	34 - 9
8ES-17653-00	15 - 11	89A-21815-00	6 - 33	8FN-2198F-00	19 - 88	8FN-23831-00	21 - 48	8H5-24560-00	23 - 6	8ET-2815K-10	34 - 10	8ET-2815K-10	34 - 10
	51 - 10	8FN-21816-00	18 - 18	8FU-2198F-01	19 - 60	8FA-23843-00	21 - 28	8FG-24610-00	23 - 2	4B5-2815K-20	35 - 2	8ET-2815K-10	34 - 10
8ES-17655-00	15 - 13	8FN-21851-00	6 - 58	8FU-2198G-00	19 - 41	8CR-23845-10	21 - 31	8FG-24641-00	23 - 3	8AC-4631K-00	28 - 65	8HR-47113-09	27 - 3
	51 - 20	8FN-21871-00	6 - 32	8GS-2198H-00	33 - 28		21 - 49	8FN-2470F-02	24 - 2	8FN-47110-01	27 - 1	8HR-47115-09	27 - 9
8BV-17656-00	16 - 3	8FN-21912-00	33 - 26	8FU-2198J-01	19 - 61	8CR-23847-00	21 - 30	8FN-2470H-01	24 - 5	8ES-47310-00	27 - 23	8AC-47310-10	28 - 82
8CR-17660-10	49 - 7	8EK-21920-01	19 - 59	8FA-21999-00	19 - 44	8FA-23847-00	21 - 50	8FN-24710-02	24 - 1	8AC-47320-00	27 - 17	8GS-47332-00	28 - 48
8CR-17660-30	16 - 1	8FN-21926-00	19 - 27	8FN-2199G-00	46 - 3	8FA-2384N-00	21 - 41	8FN-24723-00	36 - 24	8FM-47333-00	29 - 6	8GS-47332-00	28 - 48
8CM-17665-00	49 - 9	8FN-21933-01	19 - 85	4AA-22259-40	28 - 30	8FN-23851-00	20 - 25	8FN-24742-00	36 - 37	83R-47335-00	29 - 21	8GN-47336-00	28 - 97
8BU-17670-10	49 - 11	8FN-21936-00	19 - 28		28 - 64	8FN-23852-00	20 - 62	8FN-2474A-00	24 - 11	8FN-47336-10	28 - 97	83R-47337-00	29 - 1
8BU-17670-30	16 - 5	8FN-21939-00	19 - 38	4AA-22259-50	28 - 30	8DF-23857-00	21 - 7	8GS-2474B-00	24 - 13	8AC-47341-00	28 - 9	8AC-47349-00	28 - 96
8CM-17675-00	49 - 14	8CR-21939-01	19 - 37		28 - 64	8FA-23867-00	21 - 23	8FN-2474H-00	24 - 17	8AC-47366-00	28 - 80	8AC-47366-00	28 - 80
8GS-17681-01	16 - 14	8GS-2193A-01	19 - 12	4AA-22259-60	28 - 30	8FN-23867-00	21 - 14	8FN-2474W-00	24 - 12	8DF-47367-00	28 - 93	8AC-47411-10	28 - 1
8FA-17682-00	31 - 54	8FN-2193E-00	19 - 51		28 - 64	8GS-23870-00	22 - 1	8FN-24750-01	24 - 4	8AC-47414-10	28 - 7	8AC-47414-10	28 - 7
	50 - 1	8GS-21940-11	19 - 1	3YK-22472-40	20 - 28	8FA-23872-00	21 - 20	8FN-24750-01	24 - 4	8GS-25872-01	25 - 14	8AC-47416-01	28 - 41
8FA-17682-10	50 - 1	8CW-21943-00	19 - 31	8ED-23442-00	21 - 6	8FA-23872-00	21 - 24	8FN-24772-00	36 - 27	8CR-2589F-00	25 - 23	8AC-47417-00	28 - 56
8FA-17682-20	50 - 1	8GS-21943-00	19 - 42	8ES-23501-00	20 - 18	8FA-23873-01	21 - 13	8FN-2478C-00	36 - 23	8FU-25919-00	25 - 11	8AC-47418-00	28 - 36
8FA-17682-30	50 - 1	8FN-21944-01	19 - 23	8ES-23502-00	20 - 57	1UY-23894-01	21 - 26	8FN-2478E-00	36 - 33	8FU-25924-00	25 - 12	8CM-47419-10	27 - 4
8FA-17682-40	50 - 1	8FN-21947-00	19 - 10	8GS-23540-00	20 - 29	8FA-2389C-E0	22 - 5	8FN-2478E-00	36 - 33	8FU-25970-01	25 - 32	8AC-47421-00	28 - 2
8FA-17682-90	50 - 1	8FN-21949-00	19 - 73	8GS-23550-00	20 - 63	8FA-2389C-J0	22 - 5	8FN-24790-00	24 - 6	83R-47335-00	29 - 21	8ED-47422-00	28 - 4
8AV-17688-10	16 - 2	8FN-2194E-00	19 - 52	8GS-23570-00	20 - 39	8FA-2389C-S0	22 - 5	8ET-24796-00	24 - 14	8AC-47366-00	28 - 80	8AC-47424-00	29 - 4
	49 - 8	8FN-2194F-00	19 - 16	8GS-23580-00	20 - 66	8FA-2389E-00	6 - 45	3AC-24877-C0	24 - 10	8DF-47367-00	28 - 93	8AC-47424-00	29 - 4
	31 - 67	8FN-2194G-00	19 - 17	8FN-23711-00	20 - 1		22 - 9	4KN-24877-C0	37 - 32	8FN-47377-00	30 - 7	8AC-47421-00	28 - 2
8GS-18104-01	32 - 8	8FN-2194H-00	19 - 26	8DM-23712-00	20 - 2	8FN-2389K-00	21 - 35	8FN-24897-00	24 - 9	83R-47337-00	29 - 1	8AC-47341-00	28 - 9
8GS-18115-00	31 - 25	8FN-2194N-01	36 - 30	8EN-23731-01	20 - 4	8FN-2389M-00	21 - 37	8FM-24897-01	37 - 32	8AC-47349-00	28 - 96	8AC-47349-00	28 - 96
8GS-18128-01	32 - 19	8FN-2194R-01	36 - 32	8HG-23737-00	20 - 8	8FN-24111-01	23 - 1	8FN-24897-11	37 - 32	8AC-47366-00	28 - 80	8AC-47366-00	28 - 80
8GS-18152-01	32 - 10	8GS-21950-01	19 - 20	8HG-23738-00	20 - 9	8FN-24111-10	23 - 1	8FU-2580T-01	25 - 7	8DF-47367-00	28 - 93	8DF-47367-00	28 - 93
2H9-18154-00	31 - 24	8FN-21953-00	19 - 43	8ES-23743-00	20 - 16	8FN-24114-00	23 - 13	8FU-2581T-00	25 - 1	8FN-47377-00	30 - 7	8AC-47411-10	28 - 1
3X3-18157-10	31 - 28	8FN-21954-01	19 - 24	8FM-23744-00	20 - 17	8FA-2412G-00	21 - 42	55U-25854-00	25 - 21	8AC-47411-10	28 - 1	8AC-47411-10	28 - 1
8GS-18161-01	32 - 5	8FN-21959-00	19 - 74	8EK-23751-00	20 - 5	8HF-2412G-00	21 - 27	8FA-25867-00	25 - 28	8AC-47414-10	28 - 7	8AC-47414-10	28 - 7
8GS-18164-00	32 - 1	8FU-2195E-01	19 - 62	8EX-23754-00	20 - 3	8AC-2414B-01	34 - 5	8GS-25872-01	25 - 14	8AC-47416-01	28 - 41	8AC-47416-01	28 - 41
8GS-18174-00	32 - 17	8FU-2195F-01	19 - 63	8HG-23755-00	20 - 6	8FN-2414E-00	36 - 29	8CR-2589F-00	25 - 23	8AC-47417-00	28 - 56	8AC-47417-00	28 - 56
8GS-18179-01	32 - 23	8FN-21960-01	19 - 49	8HG-23756-00	20 - 7	8FN-2414G-00	36 - 16	8FU-25919-00	25 - 11	8AC-47418-00	28 - 36	8AC-47418-00	28 - 36
8GS-18191-00	31 - 23	8FN-21962-01	19 - 29	83R-23768-00	29 - 19	8FN-24181-00	22 - 3	8FU-25924-00	25 - 12	8CM-47419-10	27 - 4	8AC-47418-00	28 - 36
8GS-18511-00	31 - 85	8FN-21963-01	19 - 30	8FN-2376A-00	20 - 51	8GS-24181-00	23 - 22	8FU-25970-01	25 - 32	8AC-47419-10	27 - 4	8AC-47418-00	28 - 36
8GS-18531-00	31 - 86	8GS-21965-00	19 - 33	8FN-2376H-00	21 - 21	8FN-24182-00	22 - 4	8FN-26110-00	21 - 1	8AC-47421-00	28 - 2	8AC-47418-00	28 - 36
8GS-18541-01	31 - 22	8GS-21966-00	19 - 34	8HG-23778-00	20 - 10	8GS-24182-00	23 - 23	8DM-26240-02	26 - 4	8ED-47422-00	28 - 4	8AC-47421-00	28 - 2
8FA-2139X-00	12 - 5	8ES-2196A-01	19 - 64	8ES-23803-00	20 - 23	8FN-2418A-00	23 - 20	4SV-26280-00	33 - 43	8AC-47424-00	29 - 4	8AC-47424-00	29 - 4
8ES-21410-00	17 - 1	8FA-2196E-01	19 - 65	8FA-23811-00	21 - 11	8FN-241A3-00	36 - 20	4SV-26290-00	33 - 44	83R-47446-00	29 - 22	83R-47446-00	29 - 22
8ES-21420-00	17 - 2	8FA-2196F-00	19 - 67	8FA-23812-00	21 - 22		36 - 36	8FN-26311-00	26 - 1	8CR-47448-00	28 - 23	8CR-47448-00	28 - 23
8ES-21459-00	12 - 6	8FG-2196M-00	19 - 39	8FA-23813-01	21 - 4	8FN-241A4-00	36 - 21	8FN-26330-00	26 - 2	8FN-47456-00	28 - 13	8FN-47456-00	28 - 13
8FN-21481-00	17 - 4	8FN-2196T-00	36 - 22	8K1-23814-00	21 - 5	8FN-241A5-00	19 - 90	8FN-26351-10	25 - 38	8AC-47457-00	28 - 8	8AC-47457-00	28 - 8
8FG-21495-00	17 - 8	8GS-21970-00	19 - 50	8FN-23815-00	22 - 12	8CR-24301-00	23 - 4	4NO-27114-00	38 - 3	8AX-47458-00	28 - 10	8AX-47458-00	28 - 10
8FG-2149C-00	17 - 9	8FA-21972-01	19 - 66	8FA-23818-02	21 - 12	8FN-24311-00	23 - 14	8FA-27114-00	24 - 18	8AC-4745A-10	28 - 83	8AC-4745A-10	28 - 83
8FN-21557-00	19 - 87	8FN-21973-00	36 - 7	8FK-2381B-00	21 - 8	8GS-24311-00	23 - 14	8DM-27431-02	19 - 82	8CR-4745B-00	28 - 84	8CR-4745B-00	28 - 84
8GU-21641-00	48 - 9	8FR-2197E-00	19 - 80	8FA-23821-00	21 - 34	8FN-24311-10	23 - 15	8DM-27441-02	19 - 83	8DF-47463-01	28 - 37	8DF-47463-01	28 - 37
8ES-21745-00	18 - 14	8ES-2197H-01	33 - 27	8FN-23826-00	21 - 44	8GS-24311-10	23 - 15	8FN-28100-01	36 - 1	8DF-47464-01	28 - 38	8DF-47464-01	28 - 38

NUMERICAL INDEX

PART NO.	REF. NO.	PART NO.	REF. NO.	PART NO.	REF. NO.	PART NO.	REF. NO.	PART NO.	REF. NO.	PART NO.	REF. NO.
8GS-47465-00	28 - 17	8FN-77133-00	36 - 14	86D-77591-00	37 - 41	8FN-82305-00	45 - 1	1A2-84714-41	43 - 2	90101-10357	31 - 9
83R-47469-00	27 - 22	8FN-77134-00	33 - 9	84R-77592-00	37 - 39	8ES-82310-00	45 - 5	8FN-84717-00	43 - 6	90101-10738	28 - 33
8AC-47475-00	28 - 49	8FA-77135-00	33 - 25	83R-77595-00	37 - 33	8FN-82509-00	6 - 90	8FP-85075-00	18 - 8	90102-10044	21 - 45
8AC-47478-00	29 - 24	8FN-77140-00	33 - 21	8FN-77711-00	38 - 1	8GS-82509-00	48 - 4	8GM-85110-00	47 - 1		21 - 53
8DM-47479-00	27 - 30	8GS-77141-10	34 - 1	8GS-77735-00	38 - 6	8FJ-82510-00	45 - 20		47 - 6	90105-05644	15 - 7
8FN-47480-30	28 - 63	8U1-77157-00	37 - 43	8DM-77761-E0	34 - 6	8GL-82526-09	44 - 9	3Y6-85130-02	47 - 3		15 - 15
8FN-47480-40	28 - 63	89A-77159-00	24 - 3	8FN-77761-E0	34 - 7	8CR-82530-01	25 - 25		47 - 6		51 - 6
8FN-47480-50	28 - 63		33 - 20	8BY-77761-J0	34 - 6	5LP-82540-01	31 - 40	8FA-85720-01	18 - 7		52 - 4
8FN-47481-30	28 - 29	8FN-7715A-00	34 - 4	8FN-77761-J0	34 - 7	8FP-8254B-00	46 - 12	8GS-85752-00	23 - 9	90105-06026	1 - 6
8FN-47481-40	28 - 29	8FN-77161-00	33 - 15	8FN-77761-R1	34 - 7	8FP-82558-00	44 - 6	8CC-85790-01	6 - 29	90105-06066	7 - 3
8FN-47481-50	28 - 29	8FN-77162-00	33 - 16	8GS-77761-R1	34 - 6	8GS-82590-10	45 - 8	8ES-85885-01	10 - 45	90105-060A6	23 - 12
83R-47485-02	28 - 19	8FA-77167-10	33 - 14	8DM-77761-S0	34 - 6	8ES-82720-02	44 - 1	8ES-85991-00	45 - 2		31 - 17
	28 - 58	8FA-77171-00	38 - 8	8FN-77761-S0	34 - 7	8ET-82917-00	36 - 17	8GL-86284-09	44 - 2		31 - 73
8FN-47486-00	27 - 12	8FR-77185-00	33 - 39	86D-77762-00	36 - 10	8CN-82917-01	6 - 89	8FN-F3711-00	20 - 1	90105-06123	12 - 15
8FN-47488-00	28 - 42	8FN-77210-00	35 - 5	8BD-77762-00	36 - 10	8FA-82970-01	44 - 7	8DM-F3712-00	20 - 2	90105-06185	45 - 7
8FN-47489-00	28 - 98	82H-77223-00	35 - 6	8BD-77762-21	36 - 10	3MX-83371-11	48 - 2	8EN-F3731-01	20 - 4	90105-06734	16 - 8
8CR-47494-01	28 - 72	8FN-77251-00	35 - 1	8AC-77762-R1	36 - 10	8GL-83383-00	45 - 24	8HG-F3737-00	20 - 8	90105-07004	4 - 3
8CV-47495-00	28 - 25	8FN-77261-00	6 - 61	8GS-77763-E0	34 - 8	8GS-833A0-00	48 - 1	8HG-F3738-00	20 - 9	90105-08072	19 - 8
8GS-47511-00	30 - 1	8FN-77262-00	36 - 18	8GS-77763-J0	34 - 8	8FN-83500-01	41 - 1	8EK-F3751-00	20 - 5		21 - 9
83R-47520-10	27 - 21	8FN-77263-00	36 - 19	8GS-77763-S0	34 - 8	4XV-83513-00	41 - 9	8EX-F3754-00	20 - 3	90105-081A7	22 - 6
8FN-47532-00	30 - 4	8FN-77264-00	33 - 6	8ES-81410-00	39 - 1	4WM-83517-00	41 - 2	8HG-F3755-00	20 - 6	90105-08450	28 - 40
8GS-47541-00	31 - 1	8FN-77271-00	33 - 3	8ES-81450-01	39 - 6	4WM-83517-10	41 - 3	8HG-F3756-00	20 - 7	90105-08483	29 - 17
8GS-47543-00	31 - 32	8FN-77272-00	33 - 4	8ES-81517-01	10 - 55	5PW-8352S-00	41 - 6	8HG-F3778-00	20 - 10	90105-08552	21 - 17
8GS-47546-00	31 - 52	8FN-77273-00	33 - 5	2S3-81801-00	40 - 2	8EK-8353E-01	41 - 4	8FN-K7210-00	35 - 5	90105-10096	25 - 17
8AC-47550-00	27 - 20	8ES-77276-00	33 - 30	8FA-8181L-00	40 - 5	8EK-83572-01	41 - 5	8CR-W0041-00	25 - 19	90105-10105	28 - 78
8CR-47550-10	27 - 26	8GS-77277-00	33 - 31	2S3-8182G-00	40 - 3	8FA-83614-00	6 - 56	8FA-W0045-00	25 - 33	90105-10106	20 - 11
8EK-47550-10	27 - 27	8FA-77311-02	36 - 2	1D7-81835-00	40 - 6	8GK-83755-11	45 - 21	8FU-W0046-01	25 - 10	90105-10151	24 - 8
8EK-47551-00	45 - 23	8CR-77319-00	36 - 8	8ES-8183G-00	40 - 12	5FU-83790-20	10 - 53	3JD-W0047-10	25 - 9		24 - 16
8GS-47554-01	31 - 31	8CR-77338-00	36 - 3	8ES-81846-01	40 - 9	8CR-83912-00	25 - 24	8CR-W0048-00	25 - 13	90105-10223	31 - 64
8GS-47558-00	31 - 8	8FA-77373-00	36 - 5	5PX-81861-00	40 - 8	8DN-83912-00	25 - 24	8FU-W0057-00	25 - 8	90105-10232	20 - 52
8GS-47564-00	31 - 80	8CR-77384-01	6 - 44	8GL-81890-00	40 - 1	8FA-83922-00	25 - 39	8GS-W1246-00	6 - 71	90105-10392	20 - 53
8GS-47571-00	31 - 75		36 - 6	4DN-81940-12	46 - 7	437-83936-01	48 - 7	8GS-W176G-02	51 - 1	90105-103A1	28 - 18
8GS-47578-00	36 - 11	8FN-77390-00	36 - 13	5DM-81950-00	45 - 18	85G-83956-00	44 - 3	8FA-W176H-10	52 - 1		28 - 47
8GS-47587-90	31 - 58	8FN-77511-10	37 - 1	8DM-81950-11	45 - 19	8FA-83973-01	44 - 8	8GS-W2195-00	19 - 36		28 - 52
8CW-47591-00	31 - 16	8FN-77512-00	19 - 71	5JW-81960-00	45 - 6	8FR-83976-02	48 - 3	8FN-W2197-01	19 - 2	90105-10433	27 - 16
8GS-47591-00	31 - 19	8FN-77523-00	37 - 3	4SH-82100-22	46 - 1	8CR-8398X-00	25 - 26	8FN-W2198-01	19 - 5		28 - 22
8ES-47613-00	31 - 47	8FN-77524-00	37 - 4	8FA-82103-00	10 - 54	8R6-8399F-00	44 - 4	8CR-W2585-00	25 - 20		28 - 39
8FN-47631-00	16 - 15	8FN-77541-00	37 - 7	8FN-82115-00	46 - 10	8FN-8399N-00	42 - 9	3GM-W2585-21	25 - 20		28 - 57
8EK-47715-00	30 - 8	8FN-77542-00	37 - 11	8FN-82116-00	46 - 13	5TG-84163-00	36 - 26	8EN-W2587-00	25 - 18	90105-10436	28 - 76
8FN-77108-00	33 - 11	8FN-77543-10	37 - 14	8FA-82122-00	46 - 2	8DN-84310-01	42 - 1	8EN-W2587-10	25 - 18	90105-10549	21 - 15
8FN-77109-00	33 - 10	8FN-77544-10	37 - 15	8FA-82129-00	46 - 5	8G9-84314-00	42 - 2	8CR-W2628-10	33 - 42	90105-10739	28 - 75
8FN-77111-00-P2	33 - 1	8FN-77551-00	37 - 20	8DM-82131-10	46 - 6	8A5-84331-00	42 - 6	8FM-W4741-10	29 - 2	90105-10N51	20 - 32
8FN-77118-00	33 - 18	8FN-77552-00	37 - 23	1AE-82151-00	46 - 8	8A5-84332-00	42 - 7		29 - 3	90105-10N54	20 - 35
8FN-7711L-30	34 - 2	8FN-77553-00	37 - 26	5JJ-82151-10	45 - 11	8FN-84359-00	42 - 10	8FN-W4753-00	30 - 2	90105-12017	21 - 40
8FN-7711M-30	34 - 3	8FN-77554-00	37 - 27	5JJ-82151-20	45 - 9	8DS-84366-00	33 - 7	8FN-W7726-00	33 - 2	90105-12032	2 - 13
8FN-77130-00	33 - 8	8FA-77561-00	33 - 37	5JJ-82151-30	45 - 10	8K4-84374-00	42 - 5	90101-06047	31 - 30	90105-12N54	20 - 42
8FN-77131-00	38 - 4	8FA-77562-00	33 - 38	5JJ-82151-50	45 - 12	8DN-84397-01	42 - 3	90101-08774	27 - 11	90105-14003	31 - 89
8FN-77132-00	38 - 5	80M-77591-00	37 - 35		48 - 5	8FN-84710-00	43 - 1		27 - 42	90105-14766	16 - 25

NUMERICAL INDEX

PART NO.	REF. NO.	PART NO.	REF. NO.	PART NO.	REF. NO.	PART NO.	REF. NO.	PART NO.	REF. NO.	PART NO.	REF. NO.
90109-06015	8 - 5 13 - 10	90159-06011	33 - 36	90201-100U1	28 - 68	90209-15N50	20 - 49	90269-06006	49 - 2	90386-08002	15 - 26
		90170-08358	31 - 26		28 - 77	90210-06006	19 - 57	90269-06046	42 - 4	90386-09001	15 - 23
90109-06031	8 - 7 11 - 5	90170-10186	21 - 33	90201-10118	25 - 16		31 - 74	90269-09002	19 - 89	90386-25002	28 - 15
			21 - 52		25 - 31	90210-08017	31 - 14	90280-03045	2 - 12	90387-0514T	15 - 5
90109-06081	8 - 6	90176-10075	19 - 25	90201-10136	28 - 59	90215-10003	2 - 34	90282-07002	25 - 2		51 - 5
90109-06172	37 - 22	90179-05523	35 - 8		28 - 81	90249-06002	32 - 13	90338-20004	11 - 29	90387-0514U	15 - 14
90109-06185	12 - 12	90179-06520	37 - 6	90201-101U2	28 - 94	90261-06015	49 - 2	90338-20007	11 - 30		51 - 11
90109-06187	4 - 10		37 - 29	90201-103U4	28 - 67	90261-06019	49 - 2	90338-28242	37 - 25		52 - 3
90109-06220	33 - 35	90179-08011	37 - 31	90201-10591	2 - 35	90261-06028	49 - 2	90338-30256	33 - 29	90387-06033	43 - 4
90109-06272	37 - 21	90179-08327	2 - 4	90201-106F2	20 - 37	90261-06033	15 - 28	90340-14117	13 - 4	90387-06043	25 - 40
90109-066F0	1 - 16	90179-08655	16 - 10		20 - 48		49 - 2	90340-27129	1 - 4	90387-06058	25 - 34
90110-05034	39 - 3	90179-10679	31 - 35		20 - 56	90261-06034	49 - 2		12 - 2	90387-06059	32 - 12
90110-06043	36 - 28	90179-12004	17 - 7		28 - 88	90266-06001	49 - 2	90340-32080	13 - 2	90387-065V0	9 - 35
90110-06164	8 - 11	90183-05024	42 - 8	90201-10742	21 - 47	90266-06002	49 - 2	90380-16109	29 - 13	90387-06681	33 - 23
90110-06168	14 - 5	90183-05068	33 - 12	90201-12032	20 - 50	90267-47186	24 - 15	90380-22232	28 - 91	90387-08071	11 - 21
90110-06187	39 - 5		36 - 15	90201-120T5	17 - 10		36 - 34	90380-28235	28 - 92	90387-081M9	25 - 43
90110-06211	31 - 61	90183-06053	33 - 32	90201-12161	25 - 37		48 - 11	90380-28237	15 - 18	90387-082J1	29 - 16
90110-06223	39 - 2	90183-060A0	11 - 11	90201-121H0	2 - 14	90267-47187	19 - 70		52 - 6	90387-083G6	28 - 62
90110-06234	13 - 11		11 - 28	90201-121U3	21 - 43	90267-47195	11 - 8	90381-14001	21 - 39	90387-10008	21 - 46
90110-08N53	20 - 26	90183-06100	33 - 33	90201-12317	32 - 7		19 - 13	90381-14101	28 - 31	90387-10029	20 - 14
90111-05020	36 - 25	90183-08065	33 - 13	90201-125A3	17 - 11		19 - 45		28 - 69	90387-10031	27 - 7
90111-06042	25 - 35	90185-10110	28 - 34	90201-12790	6 - 30		19 - 78	90381-14109	28 - 73		27 - 38
90111-08054	25 - 44	90185-10115	29 - 8	90201-141A3	16 - 24		19 - 86	90381-15001	19 - 3	90387-1009S	28 - 66
90113-05053	15 - 6	90201-047R8	28 - 6	90201-16245	31 - 72		36 - 9		19 - 6	90387-100X3	28 - 74
90113-06064	30 - 6	90201-05036	33 - 40	90201-205R6	27 - 32	90267-48010	36 - 4	90381-15N50	20 - 20	90387-1012H	20 - 13
	31 - 66		47 - 4	90201-207J5	28 - 44	90267-48014	26 - 5		20 - 30	90387-1014Y	29 - 11
90119-06179	11 - 24		48 - 10	90201-210U0	28 - 14	90267-48016	19 - 14		20 - 59	90387-105G5	28 - 32
90119-08112	11 - 22	90201-05725	41 - 8	90201-222F0	16 - 22		19 - 58		20 - 64		28 - 79
90119-09004	12 - 9	90201-06037	16 - 9	90201-225A4	16 - 22		19 - 79	90381-16004	19 - 4	90387-105G6	28 - 20
90119-10004	1 - 10	90201-06042	32 - 15	90201-250T6	28 - 51	90267-48018	6 - 59		19 - 7	90387-10N58	20 - 34
90149-05129	6 - 83	90201-06050	25 - 42	90201-252F1	25 - 6		19 - 46	90381-16N51	20 - 40	90387-10N59	20 - 55
90149-05299	35 - 7	90201-06072	33 - 46	90201-25526	16 - 21		19 - 69		20 - 67	90387-12N54	20 - 44
90149-06148	6 - 37	90201-06099	31 - 29	90201-25527	25 - 5		33 - 19	90381-18N51	20 - 21	90387-1404R	28 - 70
90149-06263	38 - 2	90201-061H1	16 - 9	90201-266L1	28 - 50	90267-48023	19 - 21		20 - 60	90387-1407L	16 - 23
90149-06330	23 - 21	90201-06747	28 - 27	90201-266P2	31 - 51		19 - 47	90381-19111	28 - 16	90387-1815A	29 - 9
90149-08034	16 - 20	90201-08020	21 - 10	90201-286K9	28 - 54	90267-48083	19 - 68	90381-22099	28 - 43	90387-20022	27 - 28
90150-05040	49 - 10	90201-08053	23 - 29	90201-30013	14 - 6	90267-48086	37 - 34	90381-25115	20 - 19	90387-20023	27 - 29
	49 - 15	90201-08060	32 - 21	90201-320S3	31 - 63	90267-48095	19 - 77		20 - 58	90387-2004V	28 - 45
90150-06015	22 - 14	90201-08075	23 - 30	90202-08204	15 - 24	90267-48176	19 - 18	90381-28108	28 - 53	90387-2008G	31 - 62
90151-05048	32 - 18	90201-08326	22 - 7		51 - 15		19 - 35	90383-17001	21 - 36	90387-203H0	27 - 24
90151-06010	28 - 3	90201-08403	25 - 45	90202-09227	15 - 21	90267-48177	19 - 19	90384-16251	28 - 85	90387-22005	31 - 49
	29 - 5	90201-08649	29 - 18		51 - 17		19 - 22	90384-16N51	20 - 24	90387-25011	25 - 4
90151-06024	2 - 27	90201-08759	21 - 57		52 - 7		19 - 48	90384-19001	32 - 9	90387-25018	31 - 65
90154-06009	33 - 34	90201-08784	6 - 86	90202-16229	28 - 86	90267-48182	6 - 39	90384-38243	16 - 6	90387-2508C	31 - 12
	37 - 24	90201-100L3	27 - 15	90202-16232	28 - 87	90267-48194	28 - 5		16 - 12	90387-2515E	28 - 55
	38 - 7		28 - 21	90202-22238	29 - 10	90267-48199	28 - 11		49 - 12	90387-26007	31 - 56
90154-06062	16 - 4	90201-100S0	27 - 6	90208-26002	31 - 55	90269-05055	6 - 60	90384-41242	15 - 4	90387-30005	31 - 53
90159-05035	45 - 25		27 - 37	90209-15N50	20 - 38	90269-06006	15 - 27		52 - 2	90387-514Y2	30 - 3

NUMERICAL INDEX

PART NO.	REF. NO.	PART NO.	REF. NO.	PART NO.	REF. NO.	PART NO.	REF. NO.	PART NO.	REF. NO.	PART NO.	REF. NO.
90401-10015	25 - 15	90467-10041	9 - 28	90501-550A5	49 - 4	91401-20020	20 - 15	93306-20589	30 - 5	95307-10700	21 - 51
	25 - 30	90467-100A1	1 - 21	90501-550A6	49 - 4	91402-20020	21 - 56	93306-20601	31 - 2	95312-08600	21 - 25
90401-10043	20 - 45		13 - 13	90501-551L3	49 - 4	91609-30008	29 - 12	93306-30323	2 - 24	95602-05200	15 - 8
90430-06192	8 - 8	90467-11019	13 - 14	90501-551L9	49 - 4	91609-50032	15 - 12	93306-30579	16 - 16		15 - 16
90430-08119	1 - 8	90467-11028	9 - 5	90501-552L5	49 - 4		51 - 16	93306-30721	2 - 17	95602-06200	32 - 16
90430-08204	18 - 6		9 - 7	90501-580A1	49 - 4	91808-16023	1 - 5	93310-42239	2 - 28		33 - 24
90430-10148	31 - 41		9 - 8	90501-580A2	49 - 4	91808-22019	7 - 9	93311-32685	31 - 48		33 - 45
90430-14043	31 - 90	90467-11032	6 - 36	90501-580A3	49 - 4	91A20-05130	23 - 18	93317-21578	31 - 68	95602-08200	18 - 12
90445-112E0	6 - 34		6 - 51	90501-580A4	49 - 4	92012-06012	19 - 81		31 - 71		19 - 53
90445-11M52	9 - 27		23 - 7	90501-581L5	49 - 4	92012-08025	11 - 14		31 - 82		21 - 18
90445-120J6	6 - 50		23 - 16	90501-581L6	49 - 4	92014-06020	21 - 3		31 - 84		22 - 10
90445-120J8	6 - 35		23 - 24	90501-582L1	49 - 4	92017-06014	25 - 41	93317-33179	31 - 59	95602-10200	21 - 16
90450-28014	6 - 49	90467-110A2	6 - 3	90501-582L2	49 - 4	92902-08600	37 - 38	93317-41785	21 - 38		31 - 44
90450-35001	6 - 14		6 - 5	90501-582L6	49 - 4	92907-06600	15 - 20	93410-06053	32 - 14	95604-10200	27 - 8
	6 - 41		6 - 8	90501-582L7	49 - 4		51 - 14	93420-26077	5 - 19		27 - 39
	6 - 69		6 - 12	90501-583L0	49 - 4	92907-10600	27 - 34	93440-39175	31 - 79	95607-05200	51 - 7
	6 - 78		6 - 13	90501-583L1	49 - 4	92907-16100	15 - 32	93450-19095	2 - 9		52 - 5
90450-38040	6 - 7		6 - 18	90501-583L4	49 - 4		51 - 19		2 - 11	95607-08200	19 - 9
90450-57016	9 - 3	90467-12053	18 - 10	90501-583L5	49 - 4	92990-08200	11 - 15	93450-32152	2 - 31		20 - 27
90450-67003	9 - 25		18 - 17	90501-600A1	49 - 4	93102-10207	5 - 6	93503-08007	31 - 87		27 - 10
90460-15126	6 - 64	90467-17089	6 - 20	90501-600A4	49 - 4	93102-15212	31 - 21	93604-16092	5 - 10		27 - 41
	6 - 80		6 - 22	90501-600A5	49 - 4	93102-30012	31 - 4	93606-20044	31 - 37		28 - 60
90462-08225	13 - 8		6 - 23	90501-601L7	49 - 4	93102-35010	31 - 5	93700-06004	20 - 22		29 - 15
90462-10022	22 - 11	90467-20085	18 - 19	90501-601L8	49 - 4		31 - 34		20 - 31	95607-10100	28 - 35
90464-08126	46 - 11	90467-22080	18 - 20	90501-602L3	49 - 4	93102-45008	2 - 19		20 - 41		28 - 71
90464-09015	23 - 25	90467-22097	7 - 11	90501-602L8	49 - 4	93210-06001	40 - 4		20 - 46	95607-10200	19 - 11
90464-11007	22 - 2		7 - 12	90501-602L9	49 - 4	93210-14369	13 - 5		20 - 61		20 - 12
90464-12045	45 - 15		7 - 14	90501-603L2	49 - 4	93210-14579	7 - 7		20 - 65		20 - 33
90464-13073	26 - 3	90467-28046	6 - 66	90501-603L3	49 - 4	93210-16629	7 - 16		20 - 68		20 - 36
	45 - 14	90467-28144	6 - 63	90501-624L8	49 - 4	93210-18322	7 - 6		28 - 90		20 - 47
90464-13077	45 - 16		6 - 70	90508-500B1	49 - 6	93210-19026	18 - 3	94580-25064	7 - 18		20 - 54
90464-13194	9 - 9	90467-310A0	6 - 67	90508-536A9	49 - 6	93210-19123	1 - 15	94591-59140	4 - 4		28 - 95
90464-15195	6 - 79	90468-04092	23 - 5	90508-556A2	49 - 6	93210-24235	40 - 10	94701-00411	1 - 9	95607-12200	20 - 43
	45 - 13	90468-08104	18 - 9	90508-556A7	49 - 6	93210-24709	12 - 4	94703-00411	1 - 9		32 - 4
90464-16010	23 - 26		18 - 15	90508-60007	49 - 6	93210-25071	31 - 11	94890-09068	31 - 57	95607-14200	27 - 25
90464-20181	6 - 55	90468-12006	21 - 19	90508-60012	49 - 6	93210-25642	16 - 19		50 - 2		27 - 33
90464-25004	43 - 7	90480-16278	19 - 91	90508-60016	49 - 6	93210-26006	6 - 15	94890-09070	50 - 2	95617-08630	16 - 7
90464-35132	45 - 17	90480-18007	43 - 3	90508-60018	16 - 13	93210-32172	13 - 3	95022-06008	46 - 9		49 - 13
90465-06M28	6 - 31	90501-060A1	31 - 69		49 - 6	93210-41041	23 - 10	95022-06020	4 - 7	95702-05300	33 - 41
90465-08368	19 - 32	90501-066J5	31 - 78	90793-26123	46 - 1	93304-20511	31 - 3		6 - 28		47 - 5
90465-10038	13 - 9	90501-08668	23 - 17	91312-06016	6 - 16	93306-00006	5 - 5	95022-06085	9 - 36	95702-05500	45 - 26
90465-10048	6 - 38	90501-10353	31 - 88		7 - 17		5 - 18	95022-08012	1 - 7		47 - 2
90465-13152	48 - 8	90501-120A0	25 - 36	91312-06020	9 - 2	93306-00208	31 - 20	95022-08020	11 - 6		47 - 7
90467-08092	9 - 11	90501-130A0	32 - 11	91312-06025	5 - 16	93306-00444	27 - 18	95302-06700	40 - 7	95702-06500	6 - 82
	9 - 13	90501-407E4	29 - 20	91312-06040	5 - 15	93306-00711	31 - 38		40 - 11		9 - 34
90467-09026	9 - 14	90501-550A2	49 - 4	91312-06065	1 - 19	93306-01003	2 - 20	95307-08700	31 - 27		24 - 7
	23 - 19	90501-550A3	15 - 29	91316-06022	25 - 29	93306-20212	32 - 2	95307-10600	31 - 10		37 - 19
	23 - 27		49 - 4	91317-06016	18 - 4	93306-20511	31 - 33	95307-10700	21 - 32		43 - 5

NUMERICAL INDEX

PART NO.	REF. NO.	PART NO.	REF. NO.	PART NO.	REF. NO.	PART NO.	REF. NO.	PART NO.	REF. NO.	PART NO.	REF. NO.
95702-08300	23 - 28	95822-06016	9 - 38	99002-08600	5 - 11						
	45 - 22		45 - 3	99009-20400	28 - 46						
95702-08500	6 - 85		48 - 6	99009-24400	25 - 3						
	37 - 10	95822-06020	18 - 21	99009-25400	16 - 18						
	37 - 12		37 - 5		27 - 14						
95702-10300	21 - 54	95822-06025	31 - 46	99009-26400	31 - 50						
95702-10500	21 - 55	95822-08014	24 - 20	99009-35500	32 - 3						
95707-05300	25 - 27		32 - 20	99009-42500	27 - 19						
95707-06300	28 - 28	95822-08016	6 - 84	99009-52500	31 - 7						
95707-08500	28 - 24		19 - 75		31 - 36						
95707-10300	27 - 31		37 - 9	99009-62500	16 - 17						
95707-12300	29 - 23		37 - 16		31 - 6						
95712-08300	37 - 37		46 - 4	99246-00200	34 - 11						
95802-06014	37 - 18	95822-08020	19 - 76	99530-08012	5 - 14						
95802-06016	33 - 22		22 - 8		8 - 3						
95807-08012	18 - 5		32 - 22		13 - 7						
95812-06008	11 - 10		37 - 2	99530-10014	12 - 7						
	11 - 25	95822-08025	37 - 36	99530-10114	12 - 8						
	11 - 27		37 - 40								
95812-06012	7 - 20		37 - 42								
	32 - 24	95822-08030	31 - 42								
95812-06014	6 - 10	95822-10016	19 - 54								
95812-06016	6 - 54	95822-10020	37 - 8								
	11 - 12		37 - 17								
	18 - 11	95822-10045	31 - 43								
	19 - 56	95822-10090	31 - 45								
95812-06020	2 - 21	95827-08016	32 - 6								
95812-06040	7 - 8	95827-08220	28 - 61								
95812-06055	12 - 13	95827-10025	30 - 9								
95812-06080	12 - 14	97007-06025	28 - 26								
95812-08014	36 - 31	97007-08014	31 - 13								
	36 - 35	97012-10025	2 - 33								
95812-08016	37 - 13	97017-06030	15 - 19								
95812-08020	11 - 18		51 - 13								
95812-08030	17 - 3	97027-10025	28 - 89								
	40 - 13	97702-50016	33 - 17								
95812-08055	12 - 10		35 - 3								
95812-08070	12 - 11		41 - 7								
95817-08035	29 - 14	97702-50020	19 - 84								
95817-10030	29 - 7		35 - 4								
95817-10080	27 - 5	98502-04014	10 - 23								
	27 - 36	98502-05016	44 - 10								
95817-12100	17 - 5	98502-06016	5 - 8								
95817-12200	17 - 6	98706-04012	25 - 22								
95822-06010	45 - 4	98902-05008	23 - 11								
95822-06012	6 - 53	98902-06016	37 - 28								
	6 - 81	98902-08020	37 - 30								
	19 - 72	99001-04600	44 - 5								