

PARTS CATALOGUE

VK10D (8JE2) CANADA

VK10D (8JE1) EUROPE,RUS,JAPAN

1M8JE-100E1

()



2016/03/23

NEWS No.	DATE	COMMENT
PE0-SM-120003	Jun.,19,2012	MOD:FIG.24or28 TRACK SUSPENSION 2 LIST&ILLUST REVISION
PE0-SM-120008	Oct.,04,2012	COR:FIG.20 SKI LIST&ILLUSTRATION CORRECTION
PE0-SM-160011	Mar.,11,2016	COR:FIG.16 SECONDARY SHEAVE/31 TRACK DRIVE 2 LIST&ILLUST CORRECTION

VK10D
PARTS CATALOGUE
©2012 by Yamaha Motor Co., Ltd.
1st edition, May 2012
All rights reserved.
Any reprinting or unauthorized use
without the written permission of
Yamaha Motor Co., Ltd.
is expressly prohibited.
Printed in Japan.

FOREWORD

This Parts Catalogue is related to the parts for the model(s) on the cover page. When you are ordering replacement parts, please refer to this Parts Catalogue and quote both part numbers and part names correctly.

1. Modifications or additions which have been made after the issue of the Parts Catalogue will be announced in the Parts News.

It is advisable that you make the necessary corrections to the Parts Catalogue according to the Parts News.

2. Abbreviations

The following abbreviations are used in this Parts Catalogue.

“UR” Use specified parts number.

“UN” Use as many as needed.

“AP” Alternate Parts

“LM” Locally Made (Parts need to be ordered locally)

“F#” Frame No. (Applicable machine No.)

“O/S” Over Size

3. The number of components for assembly

- Parts, which are to be supplied in an assembly, are listed with a dot (.) in front of the part name as shown below.
- The numeral appearing to the right of each component part indicates the quantity of parts for each assembly unit.

PART NO.	DESCRIPTION	Q'TY	REMARKS
2F5-83310-60	FRONT FLASHER LIGHT ASSY	2	
115-83311-60	.BULB (6V-18W)	1	

4. Applicable colours of graphics are represented in the “REMARKS” as shown below.

PART NO.	DESCRIPTION	Q'TY	REMARKS
2N4-24110-00-X5	FUEL TANK COMP.	2	MXR
3J1-24240-10	.GRAPHIC, FUEL TANK	1	FOR MXR

5. Note that the illustrations for reference in finding parts numbers are not to be used for assembling. When assembling, please use the applicable service manual.

6. The asterisk (*) before a reference number indicates modified items after the first edition.

FOREWORD

7. Applicable Serial No.

Engine Serial No.

Frame Serial No.

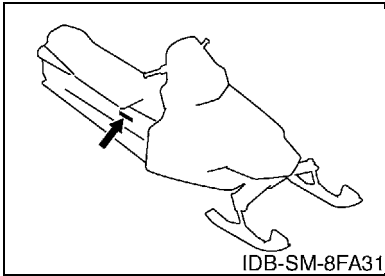
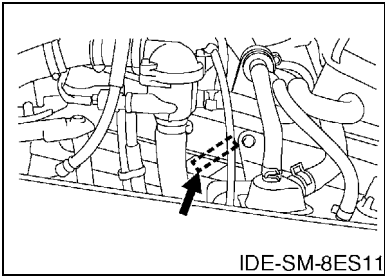

10. Applicable Starting Serial No.

Frame Serial No.

Serial No.	Name Of Q'ty Column	Model Code
JYE8JE000DA000515	8JE2	8JE2
JYE8JE000DA000135	8JE1	8JE1

8. Applicable Colour Code (The (*) mark shows Model colour.)

Abbreviation	Colour Name	Colour Code
DGNM3(*)	DARK GREENISH GRAY METALLIC 3	1194

9. Quantity Column Information

Column No.	Name Of Q'ty Column	Destination
1	8JE2	CANADA
2	8JE1	EUROPE,RUS,JAPAN

CONTENTS

ENGINE

CYLINDER HEAD	1
CRANKSHAFT & PISTON	2
VALVE	4
CAMSHAFT & CHAIN	6
WATER PUMP	7
RADIATOR & HOSE	8
OIL PUMP	12
OIL CLEANER	13
INTAKE	14
CARBURETOR	16
EXHAUST	19
CRANKCASE	21
CRANKCASE COVER 1	22
STARTER	23

DRIVE

PRIMARY SHEAVE	24
SECONDARY SHEAVE	26

BODY

ENGINE BRACKET	27
OIL TANK	28
FRAME	29
SKI	33
STEERING	36
STEERING GATE	39
FUEL TANK	40
SEAT	42
BRAKE	43
CONTROL CABLE	45
TRACK SUSPENSION 1	46
TRACK SUSPENSION 2	49
TRACK SUSPENSION 3	53
TRACK DRIVE 1	55
TRACK DRIVE 2	56
TRACK DRIVE 3	60
SHROUD	61
EMBLEM	63
WINDSHIELD	64
GUARD & LUGGAGE BOX	65
BUMPER	67

INSTRUMENT PANEL	69
------------------------	----

ELECTRICAL

GENERATOR	70
STARTING MOTOR	71
METER	72
HEADLIGHT	73
TAILLIGHT	74
HANDLE SWITCH & LEVER	75
ELECTRICAL 1	76
ELECTRICAL 2	77
ELECTRICAL 3	78
ELECTRICAL 4	79
ALTERNATE DRIVE SETTING 1	80
ALTERNATE DRIVE SETTING 2	83
ALTERNATE REBUILD KIT	84
ALTERNATE CLUTCH TUNE UP KIT	85

INDEX

NUMERICAL INDEX	86
-----------------------	----

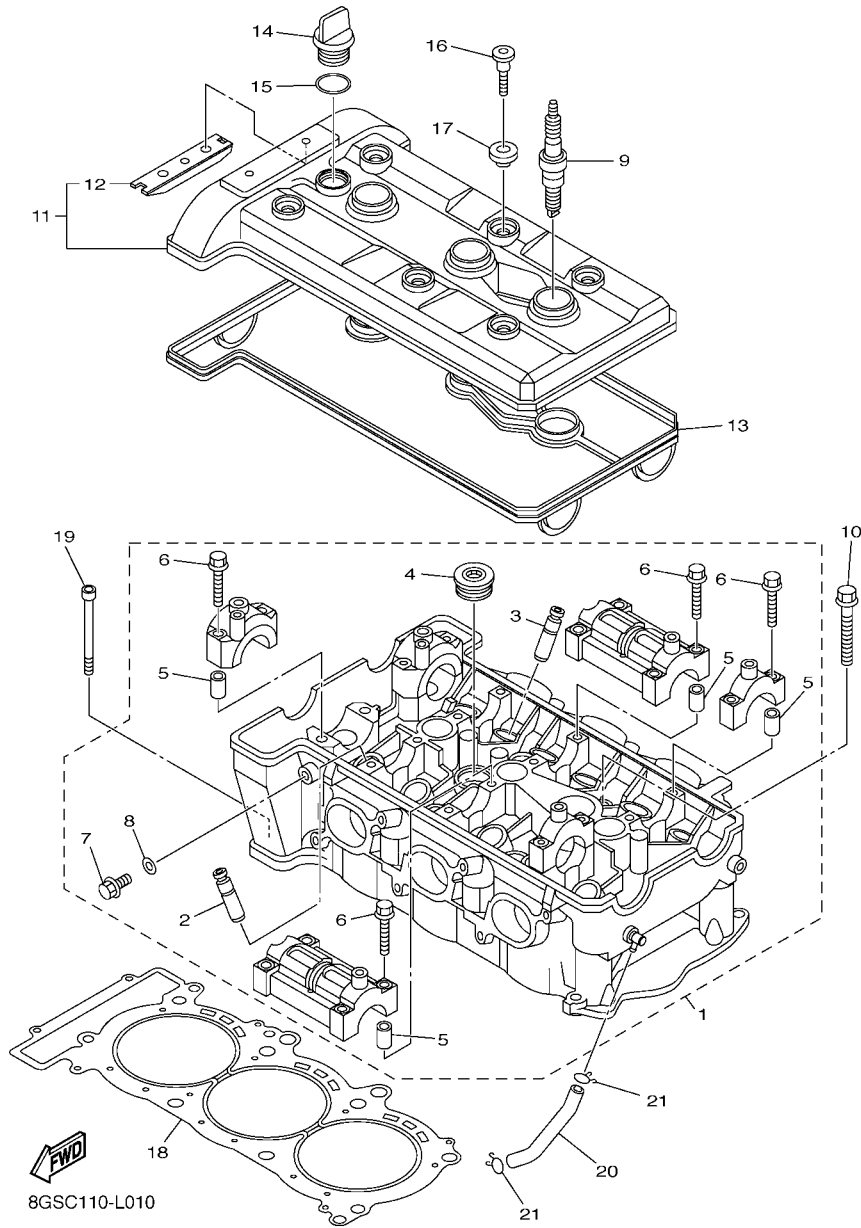

FIG. 1 CYLINDER HEAD

REF. NO.	PART NO.	DESCRIPTION	8/E2	8/E1	REMARKS
1	8ES-11101-02	CYLINDER HEAD ASSY	1	1	
2	5JW-11133-10	.GUIDE, VALVE 1	6	6	
3	3P6-11134-10	.GUIDE, VALVE 2	6	6	
4	90340-27129	.PLUG, STRAIGHT SCREW	1	1	
5	91808-16023	.PIN, DOWEL	12	12	
6	90105-06026	.BOLT, FLANGE	16	16	
7	95022-08012	.BOLT, FLANGE	1	1	
8	90430-08119	.GASKET	1	1	
9	94701-00411	PLUG, SPARK (NGK R CR8E)	3	3	UR FOR EUR,RUS
	94703-00411	PLUG, SPARK (NGK R CR8E)	3	3	UR FOR JPN
10	90119-10004	BOLT, WITH WASHER	8	8	
11	8ES-11191-01	COVER, CYLINDER HEAD 1	1	1	
12	5BE-12241-00	.GUIDE, STOPPER 2	1	1	
13	8ES-11193-00	GASKET, HEAD COVER 1	1	1	
14	3Y1-15363-10	PLUG, OIL	1	1	
15	93210-19123	O-RING	1	1	
16	90109-066F0	BOLT	6	6	
17	4KG-1111G-00	RUBBER, MOUNT 1	6	6	
18	8ES-11181-00	GASKET, CYLINDER HEAD 1	1	1	
19	91312-06065	BOLT	2	2	
20	8ES-13416-00	PIPE, OIL 1	1	1	
21	90467-100A1	CLIP	2	2	

FIG. 2 CRANKSHAFT & PISTON

REF. NO.	PART NO.	DESCRIPTION	QTY	QTY	REMARKS
1	8ES-11400-02	CRANKSHAFT ASSY	1	1	
2	5JW-11650-01	CONNECTING ROD ASSY	3	3	
3	5JW-11654-00	.BOLT, CONNECTING ROD	2	2	
4	90179-08327	.NUT	2	2	
5	5JW-11656-A0	PLANE BEARING, CONNECTING ROD	6	6	UR WHITE
5JW-11656-00	PLANE BEARING, CONNECTING ROD	6	6	UR BLUE	
5JW-11656-10	PLANE BEARING, CONNECTING ROD	6	6	UR BLACK	
5JW-11656-20	PLANE BEARING, CONNECTING ROD	6	6	UR BROWN	
5JW-11656-30	PLANE BEARING, CONNECTING ROD	6	6	UR GREEN	
5JW-11656-40	PLANE BEARING, CONNECTING ROD	6	6	UR YELLOW	
6	3LD-11416-10	PLANE BEARING, CRANKSHAFT 1	8	8	UR BLACK
3LD-11416-20	PLANE BEARING, CRANKSHAFT 1	8	8	UR BROWN	
3LD-11416-30	PLANE BEARING, CRANKSHAFT 1	8	8	UR GREEN	
3LD-11416-40	PLANE BEARING, CRANKSHAFT 1	8	8	UR YELLOW	
3LD-11416-50	PLANE BEARING, CRANKSHAFT 1	8	8	UR PINK	
3LD-11416-60	PLANE BEARING, CRANKSHAFT 1	8	8	UR RED	
3LD-11416-70	PLANE BEARING, CRANKSHAFT 1	8	8	UR WHITE	
7	8ES-11631-00	PISTON (STD)	3	3	
8	5JW-11603-00	PISTON RING SET (STD)	3	3	
9	93450-19095	CIRCLIP	3	3	
10	5JW-11633-00	PIN, PISTON	3	3	
11	93450-19095	CIRCLIP	3	3	
12	90280-03045	KEY, WOODRUFF	1	1	
13	90105-12032	BOLT, FLANGE	1	1	
14	90201-121H0	WASHER, PLATE	1	1	
15	59J-11455-00	SHAFT 1	1	1	
16	8ES-11406-02	SHAFT ASSY	1	1	

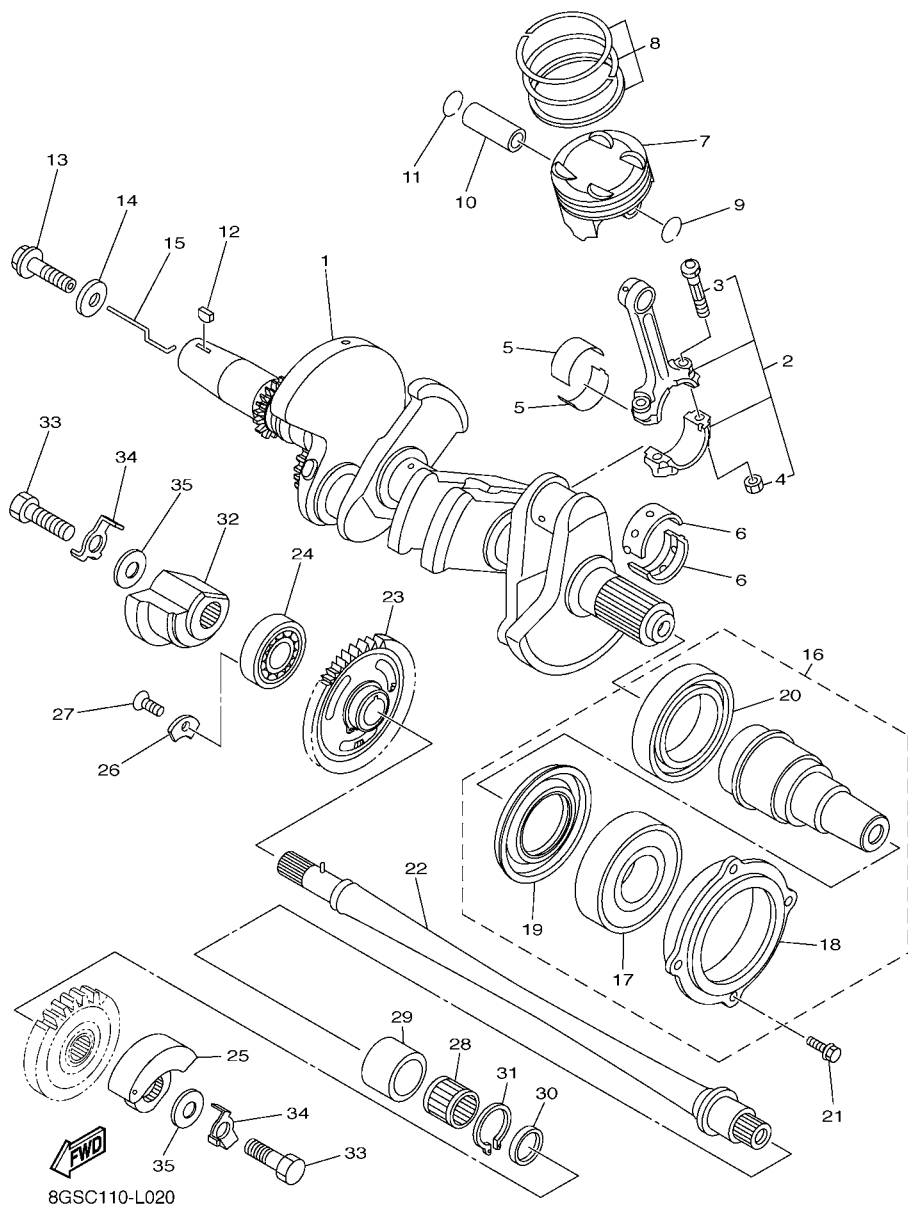
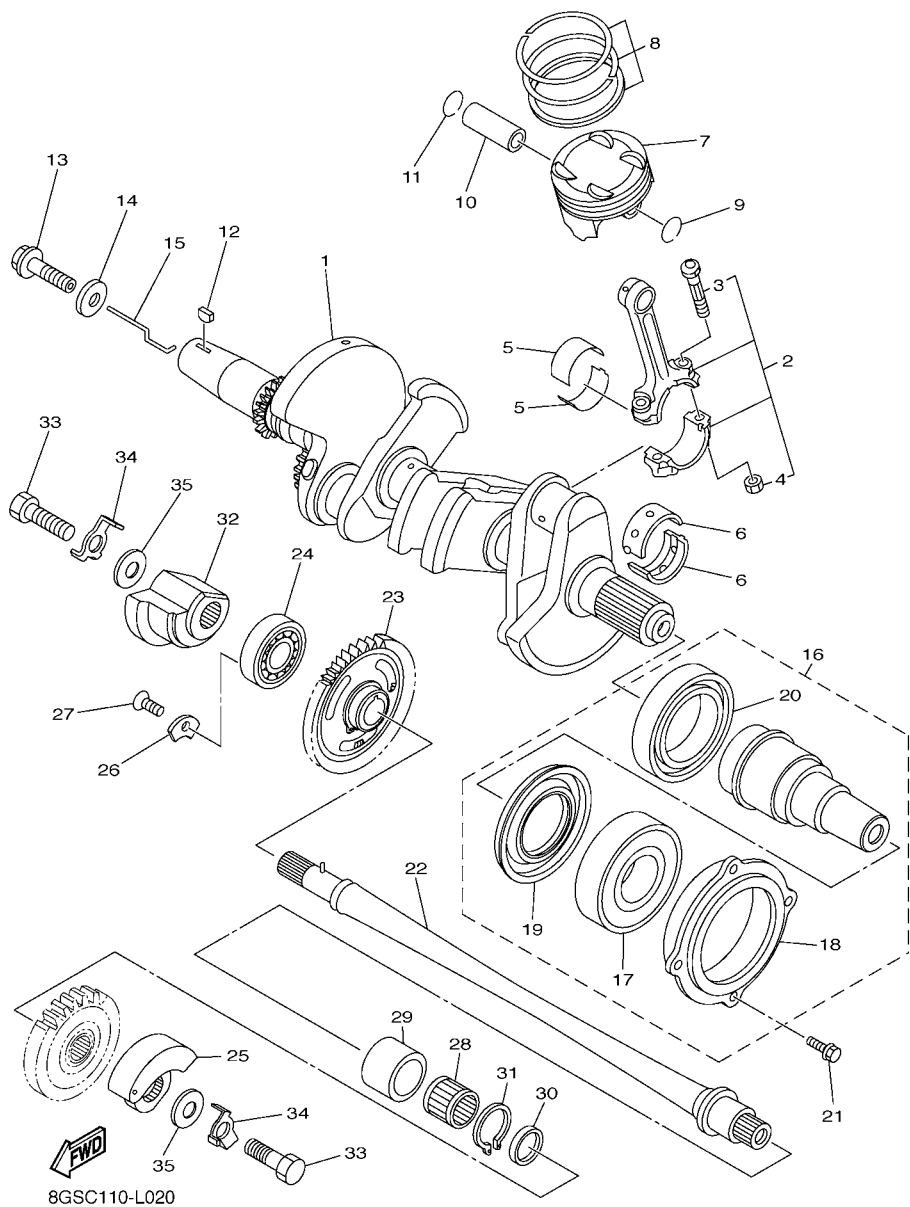
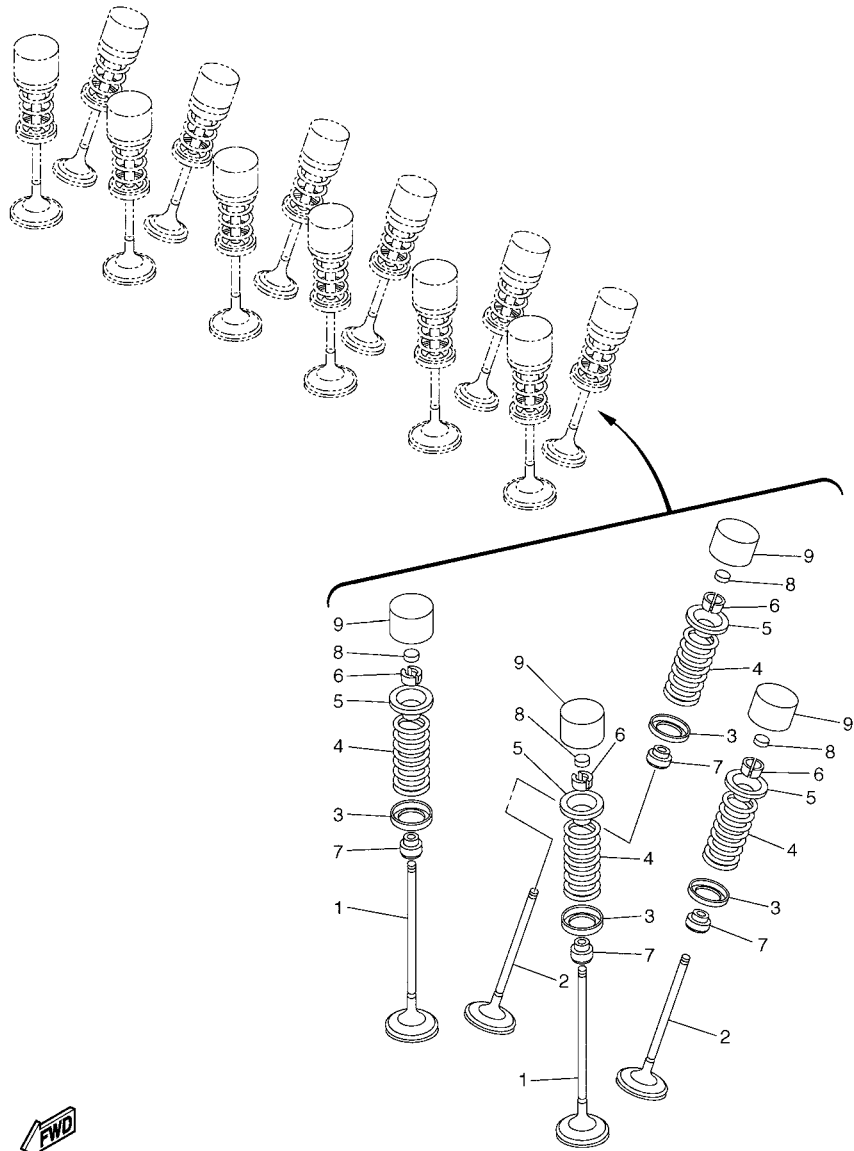

FIG. 2 CRANKSHAFT & PISTON

REF. NO.	PART NO.	DESCRIPTION	QTY	QTY	REMARKS
17	93306-30721	.BEARING	1	1	
18	8ES-16775-00	.HOUSING, BEARING	1	1	
19	93102-45008	.OIL SEAL	1	1	
20	93306-01003	.BEARING	1	1	
21	95812-06020	BOLT, FLANGE	4	4	
22	8ES-11407-02	SHAFT ASSY., 2	1	1	
23	8ES-11530-00	BALANCER WEIGHT GEAR COMP.	1	1	
24	93306-30323	BEARING	1	1	
25	8ES-11454-00	WEIGHT 1	1	1	
26	4JT-15381-01	PLATE, BEARING COVER	1	1	
27	90151-06024	SCREW, COUNTERSUNK	1	1	
28	93310-42239	BEARING	1	1	
29	8ES-11428-01	BEARING 1	1	1	
30	8ES-11478-00	COLLAR	1	1	
31	93450-32152	CIRCLIP	1	1	
32	8ES-11464-00	WEIGHT 2	1	1	
33	97012-10025	BOLT	2	2	
34	90215-10003	WASHER, LOCK	2	2	
35	90201-10591	WASHER, PLATE	2	2	





FWD
8ES1100-D030

FIG. 3 VALVE

REF. NO.	PART NO.	DESCRIPTION	Q/EZ	Q/EI	REMARKS
1	5JW-12111-00	VALVE, INTAKE	6	6	
2	5JW-12121-01	VALVE, EXHAUST	6	6	
3	5JW-12116-00	SEAT, VALVE SPRING	12	12	
4	5JW-12113-00	SPRING, VALVE INNER	12	12	
5	5JW-12117-00	RETAINER, VALVE SPRING	12	12	
6	1AA-12118-00	COTTER, VALVE	24	24	
7	3P6-12129-00	SEAL, VALVE STEM	12	12	
8	3LD-12168-00	PAD, ADJUSTING (1.20)	12	12	UR
	3LD-12168-20	PAD, ADJUSTING (1.25)	12	12	UR
	3LD-12168-40	PAD, ADJUSTING (1.30)	12	12	UR
	3LD-12168-60	PAD, ADJUSTING (1.35)	12	12	UR
	3LD-12168-80	PAD, ADJUSTING (1.40)	12	12	UR
	3LD-12168-A0	PAD, ADJUSTING (1.45)	12	12	UR
	3LD-12168-F0	PAD, ADJUSTING (1.50)	12	12	UR
	3LD-12168-H1	PAD, ADJUSTING (1.55)	12	12	UR
	3LD-12168-K1	PAD, ADJUSTING (1.60)	12	12	UR
	3LD-12168-M1	PAD, ADJUSTING (1.65)	12	12	UR
	3LD-12168-R1	PAD, ADJUSTING (1.70)	12	12	UR
	3LD-12168-U1	PAD, ADJUSTING (1.75)	12	12	UR
	3LD-12168-W1	PAD, ADJUSTING (1.80)	12	12	UR
	3LD-12168-Y1	PAD, ADJUSTING (1.85)	12	12	UR
	3LD-12169-11	PAD, ADJUSTING (1.90)	12	12	UR
	3LD-12169-31	PAD, ADJUSTING (1.95)	12	12	UR
	3LD-12169-50	PAD, ADJUSTING (2.00)	12	12	UR
	3LD-12169-70	PAD, ADJUSTING (2.05)	12	12	UR
	3LD-12169-90	PAD, ADJUSTING (2.10)	12	12	UR
	3LD-12169-E0	PAD, ADJUSTING (2.15)	12	12	UR

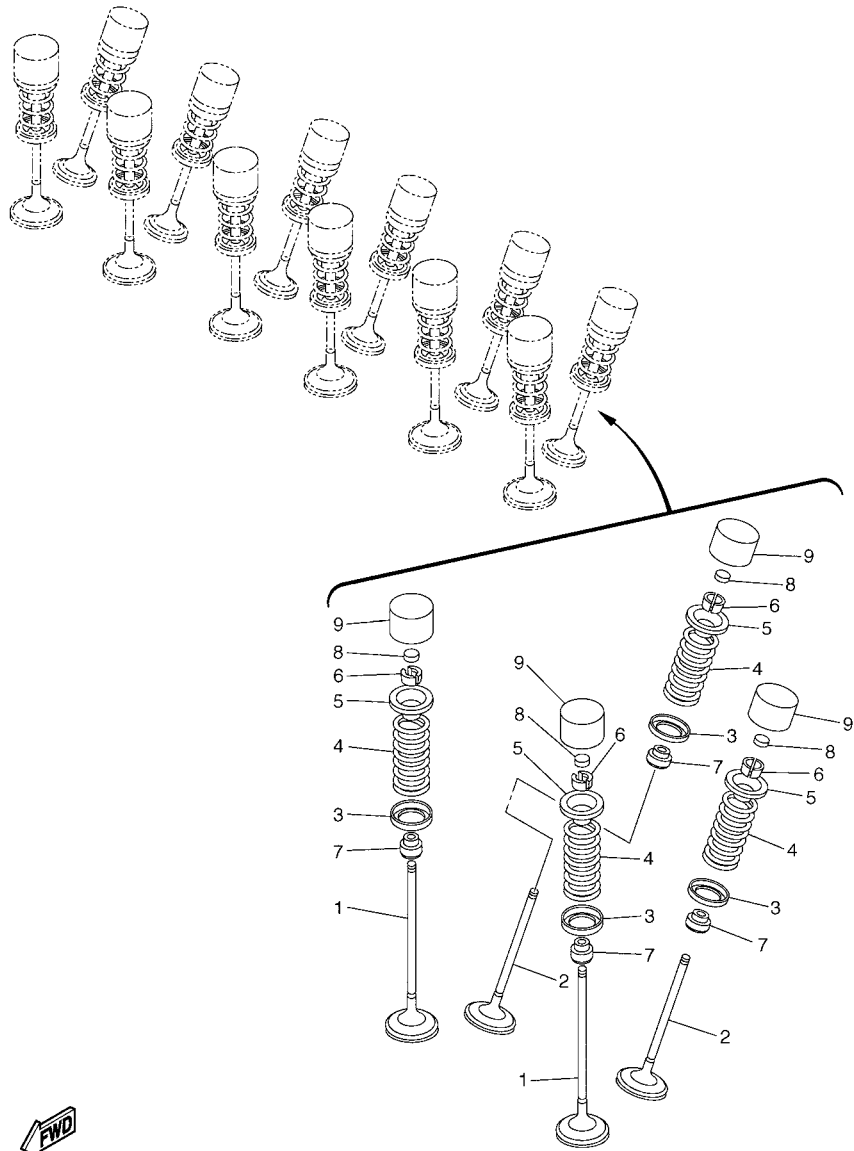

FWD
8ES1100-D030

FIG. 3 VALVE

REF. NO.	PART NO.	DESCRIPTION	B/E2	B/E1	REMARKS
8	3LD-12169-G0	PAD, ADJUSTING (2.20)	12	12	UR
	3LD-12169-J0	PAD, ADJUSTING (2.25)	12	12	UR
	3LD-12169-L0	PAD, ADJUSTING (2.30)	12	12	UR
	3LD-12169-N0	PAD, ADJUSTING (2.35)	12	12	UR
	3LD-12169-T0	PAD, ADJUSTING (2.40)	12	12	UR
9	5EB-12153-10	LIFTER, VALVE	12	12	UR YELLOW
	5EB-12153-09	LIFTER, VALVE (O/S)	12	12	UR GREEN

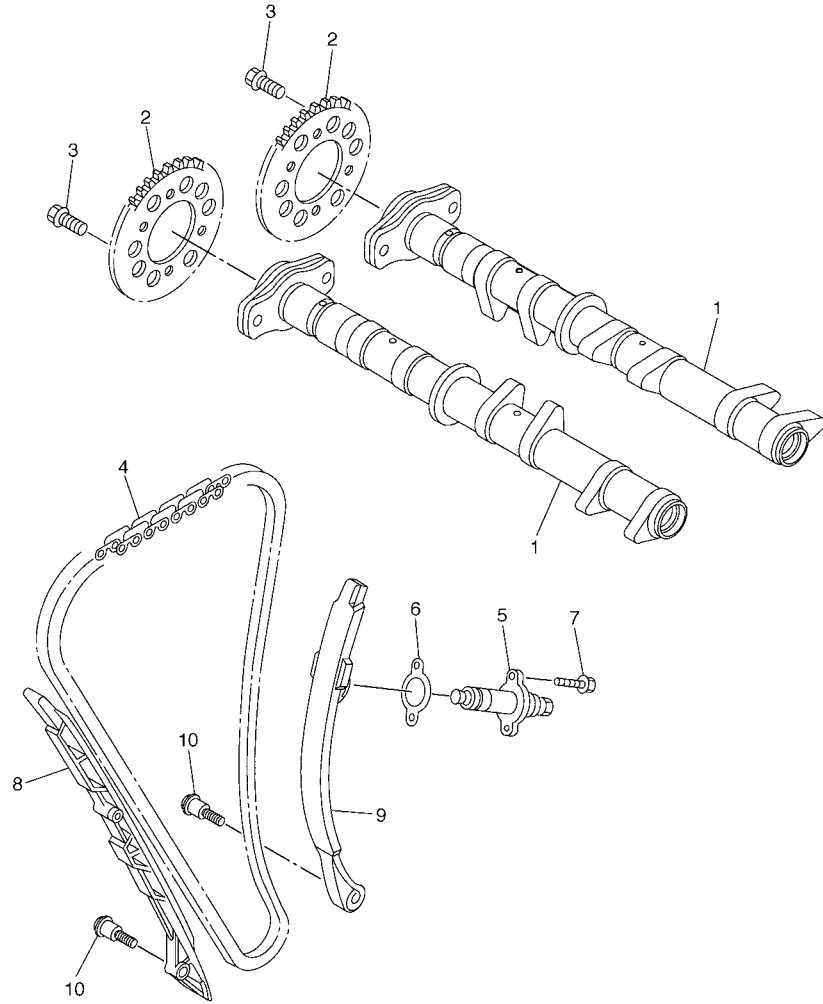

8ES1100-D040

FIG. 4 CAMSHAFT & CHAIN

REF. NO.	PART NO.	DESCRIPTION	Q/EZ	Q/EI	REMARKS
1	8ES-12170-01	CAMSHAFT ASSY 1	2	2	
2	8ES-12176-00	SPROCKET, CAM CHAIN	2	2	
3	90105-07004	BOLT, FLANGE	4	4	
4	94591-59140	CHAIN	1	1	
5	8ES-12210-01	TENSIONER ASSY, CAM CHAIN	1	1	
6	4FM-12213-00	GASKET, TENSIONER CASE	1	1	
7	95022-06020	BOLT, FLANGE	2	2	
8	8ES-12251-00	DAMPER, CHAIN 1	1	1	
9	8ES-12252-00	DAMPER, CHAIN 2	1	1	
10	90109-06187	BOLT	2	2	

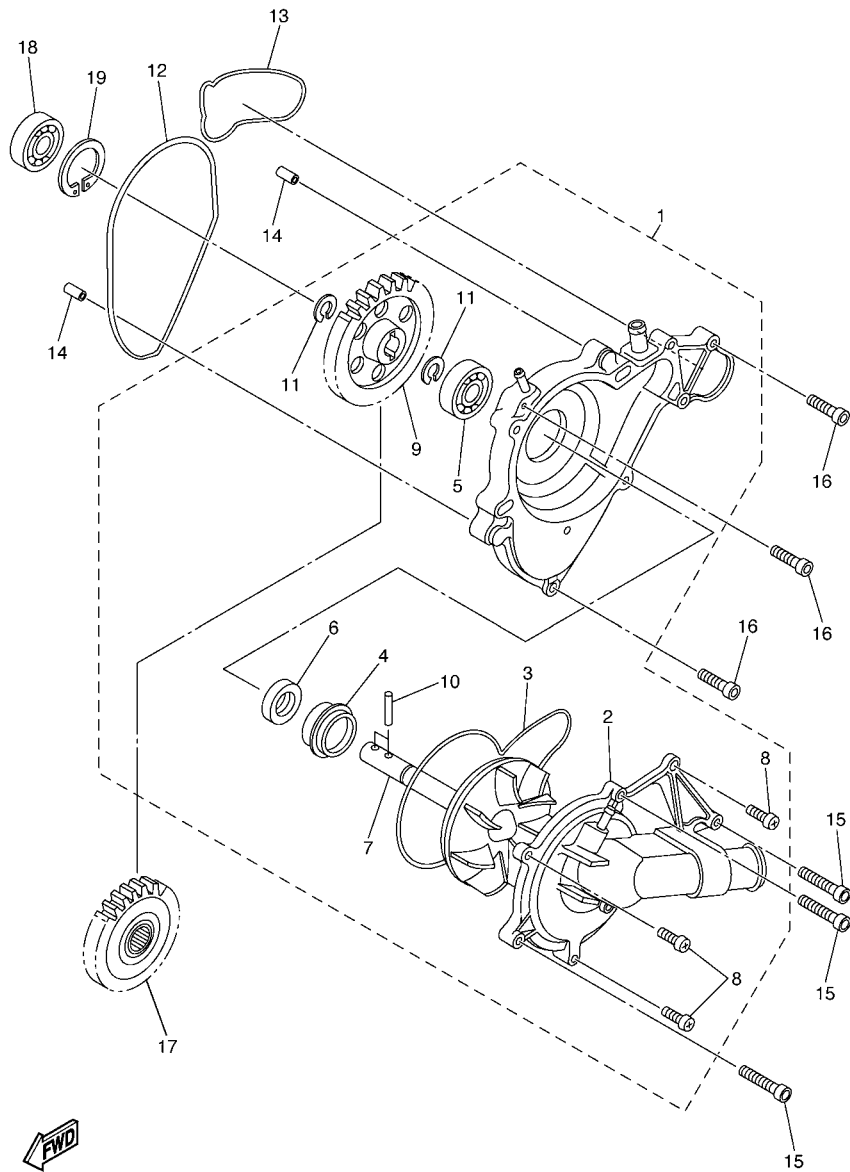

8FJ3100-E050

FIG. 5 WATER PUMP

REF. NO.	PART NO.	DESCRIPTION	QTY	QTY	REMARKS
1	8ES-12420-02	WATER PUMP ASSY	1	1	
2	8ES-12422-00	.COVER, HOUSING	1	1	
3	8ES-12427-00	.GASKET, HOUSING COVER 1	1	1	
4	8ES-12438-00	.SEAL, MECHANICAL	1	1	
5	93306-00006	.BEARING	1	1	
6	93102-10207	.OIL SEAL (SD 10-21-5 HS)	1	1	
7	8ES-12450-01	.IMPELLER SHAFT ASSY	1	1	
8	98502-06016	.SCREW, PAN HEAD	3	3	
9	8ES-12459-01	.GEAR, IMPELLER SHAFT	1	1	
10	93604-16092	.PIN, DOWEL	2	2	
11	99002-08600	.CLIP	2	2	
12	8ES-12435-00	GASKET	1	1	
13	8ES-12434-00	GASKET	1	1	
14	99530-08012	PIN, DOWEL	2	2	
15	91312-06040	BOLT	4	4	
16	91312-06025	BOLT	3	3	
17	8ES-12436-00	GEAR, DRIVE	1	1	
18	93306-00006	BEARING	1	1	
19	93420-26077	CIRCLIP	1	1	

FIG. 6 RADIATOR & HOSE

REF. NO.	PART NO.	DESCRIPTION	QTY	REMARKS
1	8ES-12482-00	PIPE 2	1	
2	8ES-12485-01	PIPE 5	1	
3	90467-110A2	CLIP	2	
4	8FN-12577-00	HOSE 2	1	
5	90467-110A2	CLIP	1	
6	8FN-1243E-00	HOSE 2	1	
7	90450-38040	HOSE CLAMP ASSY	1	
8	90467-110A2	CLIP	1	
9	8FW-1249A-00	COCK ASSY	1	
10	95812-06014	BOLT, FLANGE	2	
11	8FN-12579-00	HOSE 4	1	
12	90467-110A2	CLIP	1	
13	90467-110A2	CLIP	1	
14	90450-35001	HOSE CLAMP ASSY	1	
15	93210-26006	O-RING	1	
16	91312-06016	BOLT	1	
17	8ES-12578-00	HOSE 3	1	
18	90467-110A2	CLIP	2	
19	8ES-12588-00	HOSE 5	1	
20	90467-17089	CLIP	2	
21	8FN-12589-00	HOSE 6	1	
22	90467-17089	CLIP	1	
23	90467-17089	CLIP	1	
24	8FN-12580-10	JOINT ASSY	1	
25	5EB-12413-00	.COVER, THERMOSTAT	1	
26	8FN-12410-00	.THERMOSTAT ASSY	1	
27	8EK-12412-00	..SEAL, THERMOSTAT	1	

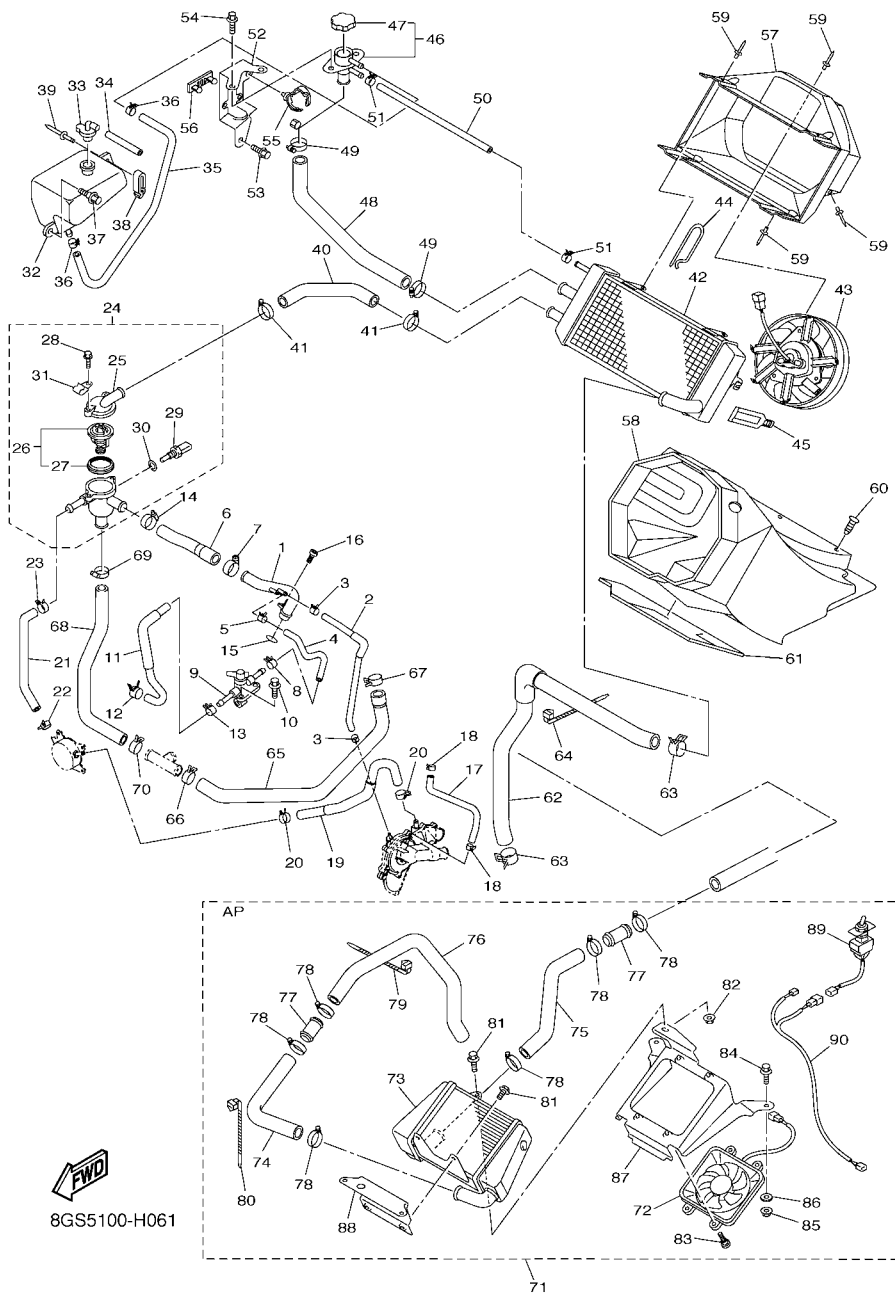

FIG. 6 RADIATOR & HOSE

REF. NO.	PART NO.	DESCRIPTION	B/E2	B/E1	REMARKS
28	95022-06020	.BOLT, FLANGE	2	2	
29	5YP-85790-00	.THERMOSENSOR ASSY	1	1	
30	90201-12790	.WASHER, PLATE	1	1	
31	90465-06M28	.CLAMP	1	1	
32	8FN-21871-00	TANK, RECOVERY	1	1	

33	89A-21815-00	CAP	1	1	
34	90445-112E0	HOSE (L70)	1	1	
35	90445-120J8	HOSE (L450)	1	1	
36	90467-11032	CLIP	2	2	
37	90149-06148	SCREW	2	2	

38	90465-10048	CLAMP	1	1	
39	90267-48182	RIVET, BLIND (4.8X23)	1	1	
40	8FN-1244G-00	HOSE, 4	1	1	
41	90450-35001	HOSE CLAMP ASSY	2	2	
42	8FN-12460-00	RADIATOR ASSY	1	1	
43	8FN-12405-01	BLOWER ASSY	1	1	

44	8CR-77384-01	PIN	1	1	
45	8FA-2389E-00	LATCH	1	1	
46	8FN-12590-00	CONDUCTION ASSY	1	1	
47	3XP-12462-00	.CAP, RADIATOR	1	1	

48	8FN-1244H-00	HOSE 5	1	1	
49	90450-28014	HOSE CLAMP ASSY	2	2	
50	90445-120J6	HOSE (L250)	1	1	
51	90467-11032	CLIP	2	2	
52	8FN-1244E-00	BRACKET 1	1	1	

53	95822-06012	BOLT, FLANGE	2	2	
54	95812-06016	BOLT, FLANGE	2	2	

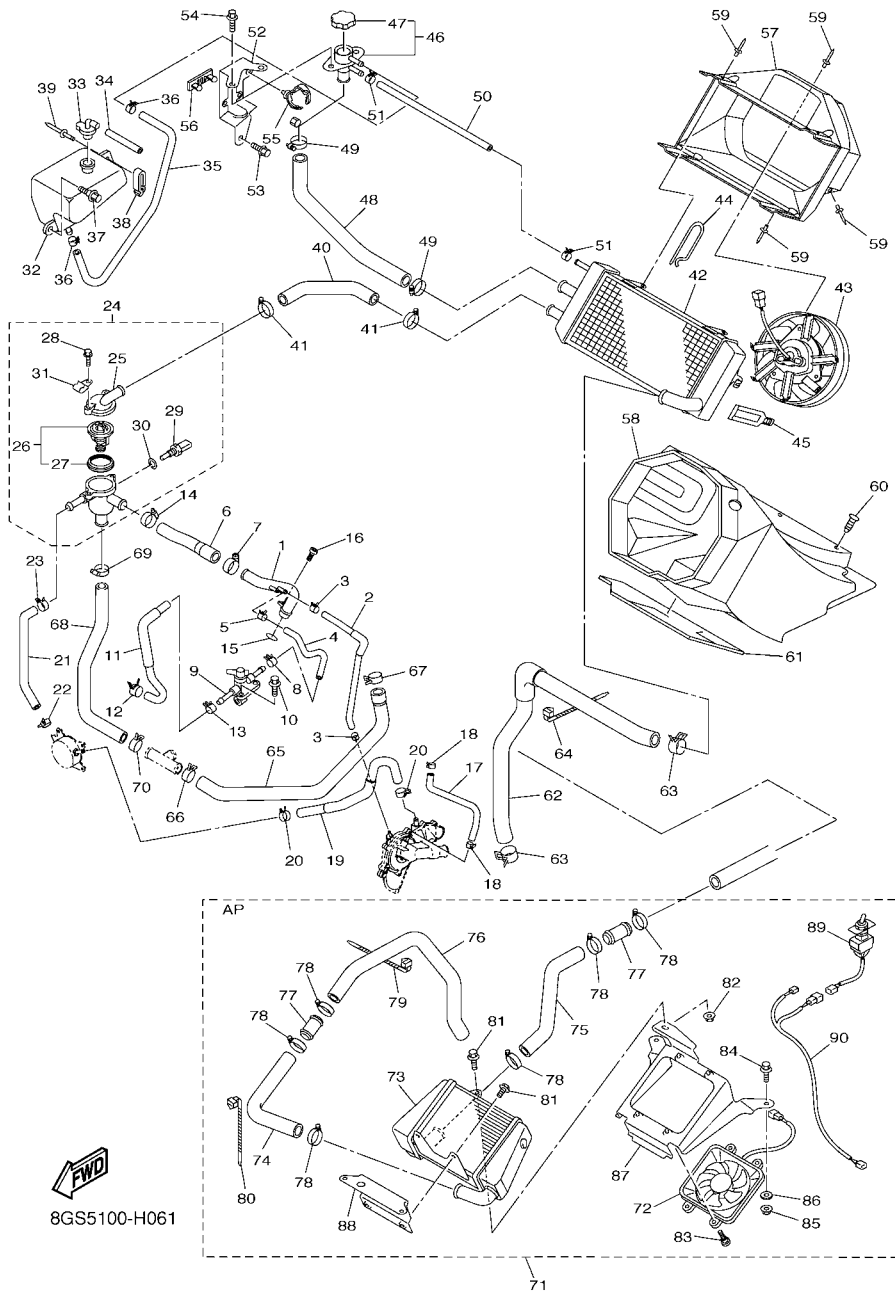

8GS5100-H061

FIG. 6 RADIATOR & HOSE

REF. NO.	PART NO.	DESCRIPTION	QTY	QTY	REMARKS
55	90464-20181	CLAMP	1	1	
56	8FA-83614-00	BRACKET	1	1	
57	8FN-12467-00	COVER, RADIATOR	1	1	
58	8FN-21851-00	DUCT, COOLER	1	1	
59	90267-48018	RIVET, BLIND (4.8X18.6 BLACK)	7	7	
60	90269-05055	RIVET	6	6	
61	8FN-77261-00	LINING, SHROUD 1	1	1	
62	8FN-12477-02	PIPE 7	1	1	
63	90467-28144	CLIP	2	2	
64	90460-15126	CLAMP, HOSE	1	1	
65	8FN-1248A-00	PIPE 8	1	1	
66	90467-28046	CLIP	1	1	
67	90467-310A0	CLIP	1	1	
68	8FN-1248E-00	PIPE 9	1	1	
69	90450-35001	HOSE CLAMP ASSY	1	1	
70	90467-28144	CLIP	1	1	
71	8GS-W1246-01	VK10 SUB RADIATOR KIT	1	1	AP
72	8FP-12405-01	.BLOWER ASSY	1	1	AP
73	8GS-12461-00	.RADIATOR COMP	1	1	AP
74	8FN-1244J-00	.HOSE 6	1	1	AP
75	8FN-1243A-00	.HOSE 1	1	1	AP
76	8FN-1243F-00	.HOSE,3	1	1	AP
77	8FN-12469-00	.JOINT 1	2	2	AP
78	90450-35001	.HOSE CLAMP ASSY	6	6	AP
79	90464-15195	.CLAMP	1	1	AP
80	90460-15126	.CLAMP, HOSE	1	1	AP
81	95822-06012	.BOLT, FLANGE	3	3	AP

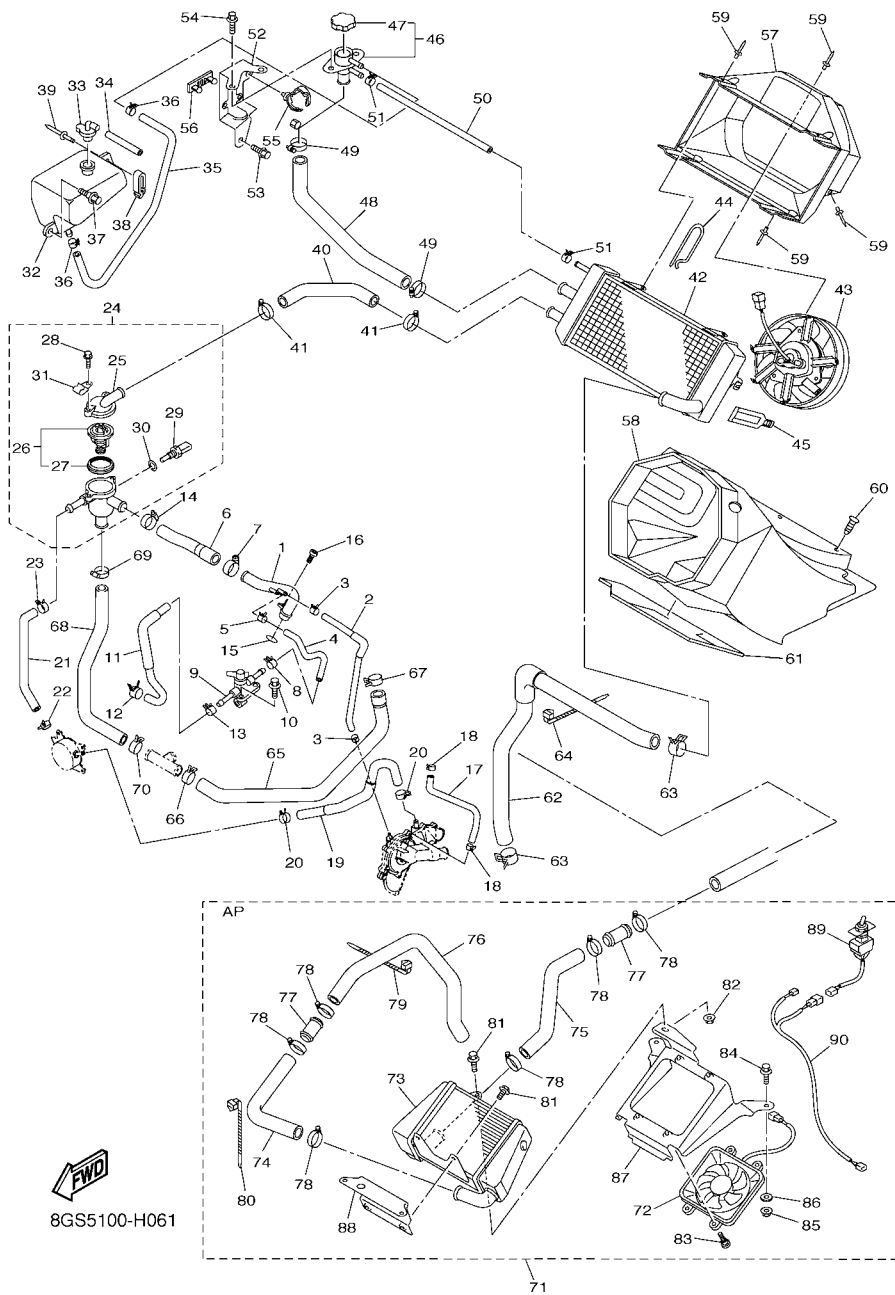
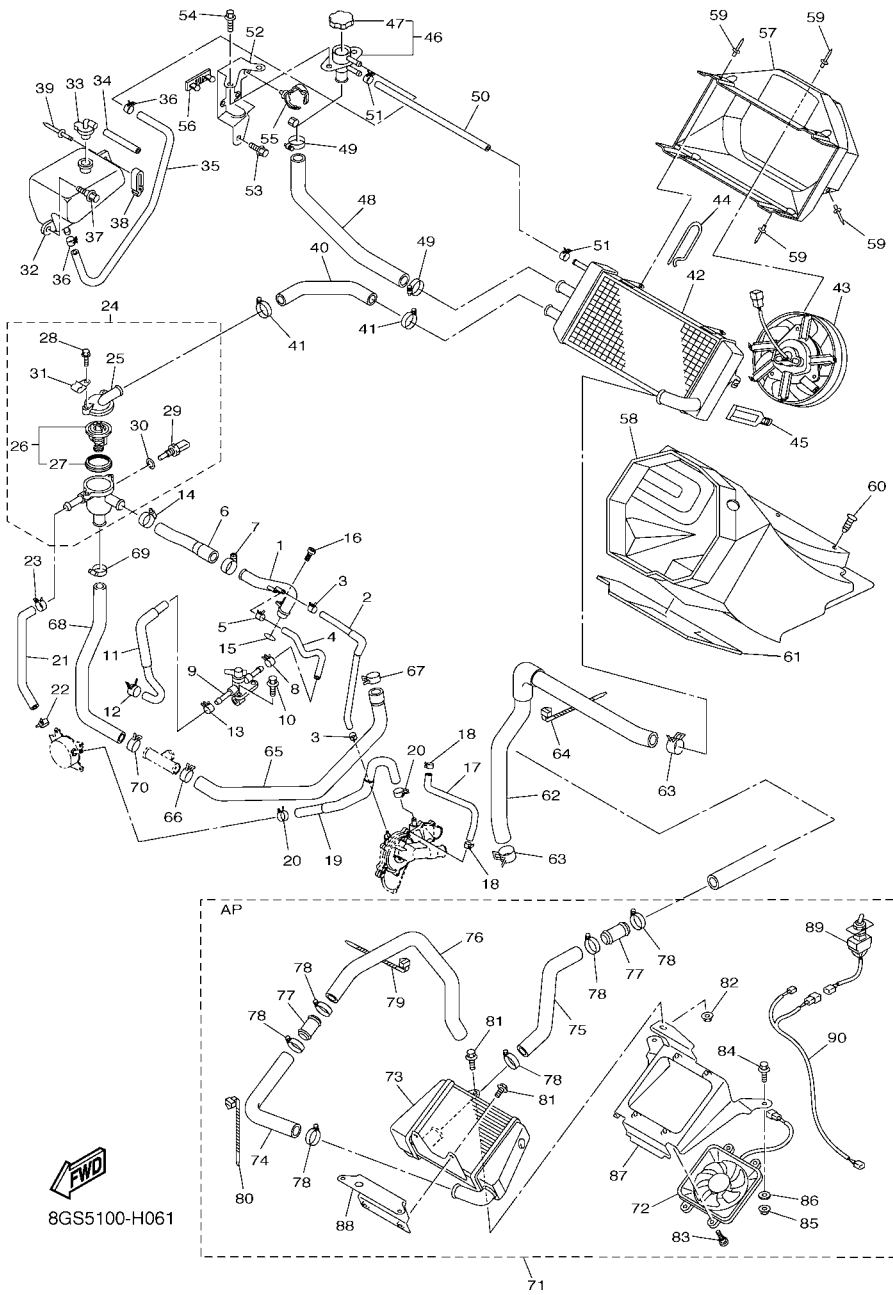
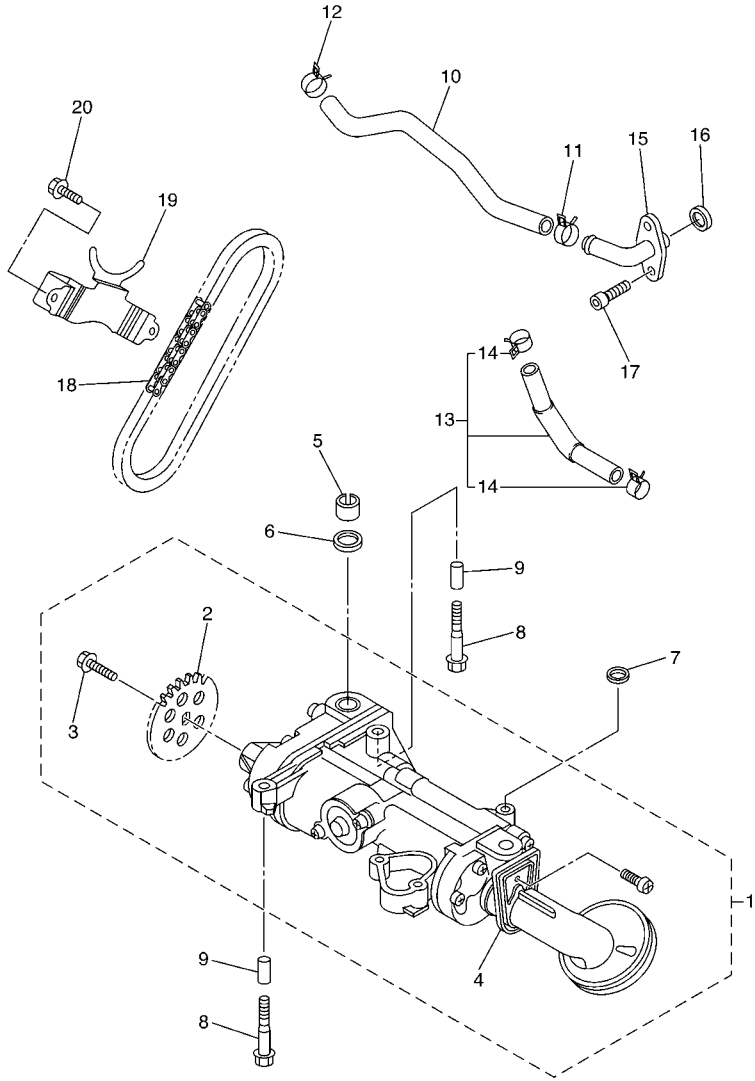

FIG. 6 RADIATOR & HOSE

REF. NO.	PART NO.	DESCRIPTION	QTY	QTY	REMARKS
82	95702-06500	.NUT, FLANGE	1	1	AP
83	90149-05129	.SCREW	4	4	AP
84	95822-08016	.BOLT, FLANGE	2	2	AP
85	95702-08500	.NUT, FLANGE	2	2	AP
86	90201-08784	.WASHER, PLATE	2	2	AP
87	8FN-1244F-00	.BRACKET 2	1	1	AP
88	8FN-12464-00	.STAY, RADIATOR	1	1	AP
89	8CN-82917-01	.SWITCH	1	1	AP
90	8FN-82509-00	.WIRE, SUB LEAD	1	1	AP





8GS3100-G070

FIG. 7 OIL PUMP

REF. NO.	PART NO.	DESCRIPTION	8/E2	8/E1		REMARKS
1	8ES-13300-00	OIL PUMP ASSY	1	1		
2	4XV-13355-00	.SPROCKET, DRIVEN	1	1		
3	90105-06066	.BOLT, FLANGE	1	1		
4	8ES-13427-00	.SPACER, STRAINER	1	1		
5	8ES-13284-00	PIPE	1	1		
6	93210-18322	O-RING	1	1		
7	93210-14579	O-RING	1	1		
8	95812-06040	BOLT, FLANGE	5	5		
9	91808-22019	PIN, DOWEL	2	2		
10	8FN-13464-00	HOSE, OIL 1	1	1		
11	90467-22097	CLIP	1	1		
12	90467-22097	CLIP	1	1		
13	8FN-1319B-02	HOSE SUB-ASSY., 2	1	1		
14	90467-22097	.CLIP	2	2		
15	8ES-13115-00	CONNECTOR, SUCTION PIPE	1	1		
16	93210-16629	O-RING	1	1		
17	91312-06016	BOLT	2	2		
18	94580-25064	CHAIN	1	1		
19	8ES-13898-00	HOLDER	1	1		
20	95812-06012	BOLT, FLANGE	2	2		

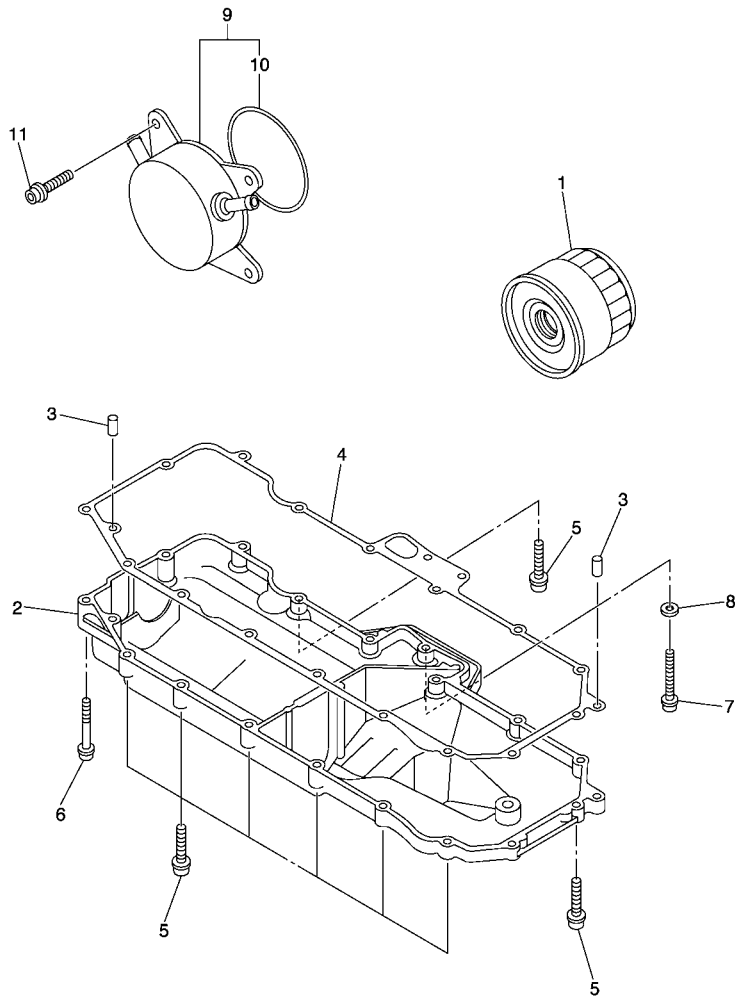

8GF3100-F080

FIG. 8 OIL CLEANER

REF. NO.	PART NO.	DESCRIPTION	8/JE2	8/JE1	REMARKS
1	5DM-13440-00	ELEMENT ASSY, OIL CLEANER	1	1	
2	8ES-13417-00	COVER, STRAINER	1	1	
3	99530-08012	PIN, DOWEL	2	2	
4	8ES-13414-01	GASKET, STRAINER COVER	1	1	
5	90109-06015	BOLT	15	15	
6	90109-06081	BOLT	2	2	
7	90109-06031	BOLT	1	1	
8	90430-06192	GASKET	1	1	
9	8ES-13470-01	OIL COOLER ASSY	1	1	
10	5JW-13473-00	.O-RING	1	1	
11	90110-06164	BOLT, HEXAGON SOCKET HEAD	4	4	

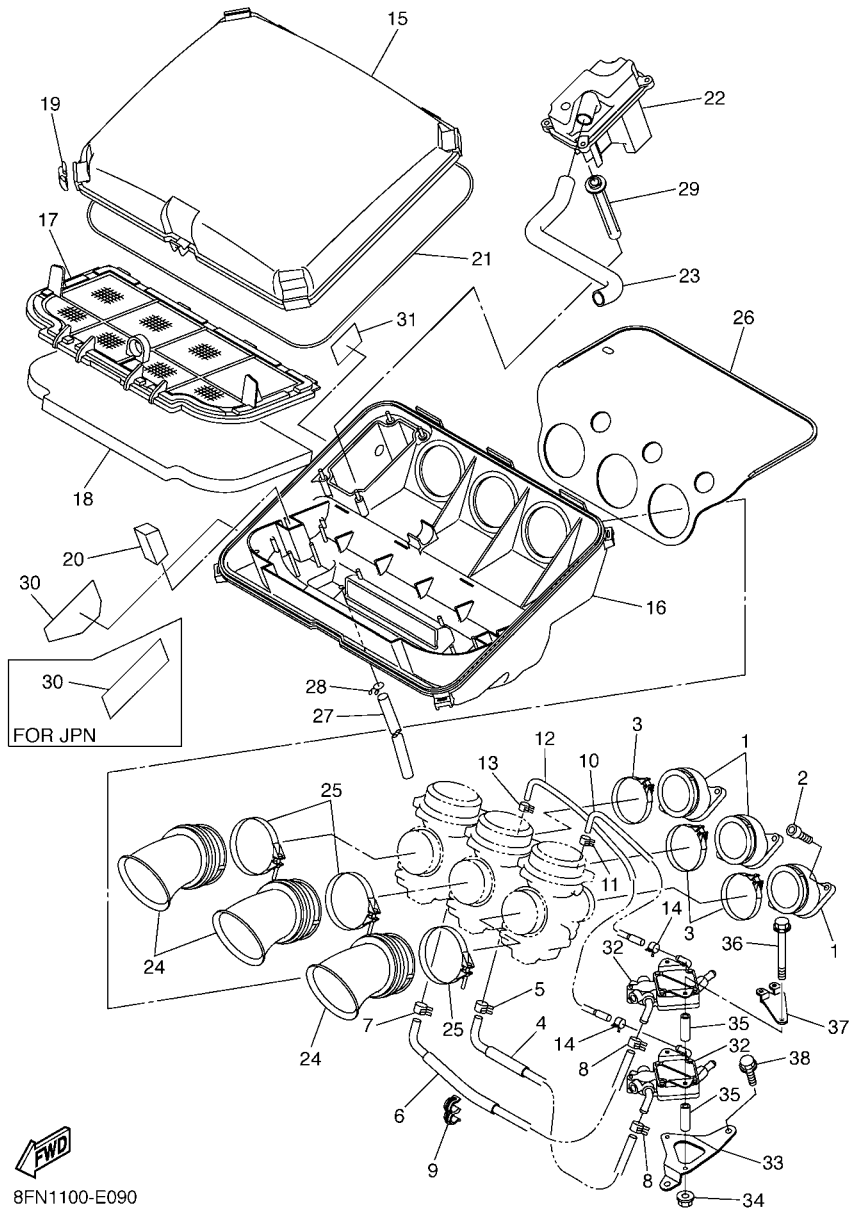

8FN1100-E090

FIG. 9 INTAKE

REF. NO.	PART NO.	DESCRIPTION	8/E2	8/E1	REMARKS
1	8ES-13586-10	JOINT, CARBURETOR 1	3	3	
2	91312-06020	BOLT	6	6	
3	90450-57016	HOSE CLAMP ASSY	3	3	
4	8ES-14294-10	HOSE	1		
	8ES-14294-00	HOSE		1	
5	90467-11028	CLIP	1	1	
6	8ES-14298-10	PIPE	1		
	8ES-14298-00	PIPE		1	
7	90467-11028	CLIP	1	1	
8	90467-11028	CLIP	2	2	
9	90464-13194	CLAMP	1	1	
10	8ES-13895-00	HOSE, AIR	1	1	
11	90467-08092	CLIP	1	1	
12	8ES-13892-00	HOSE, AIR 2	1	1	
13	90467-08092	CLIP	1	1	
14	90467-09026	CLIP	2	2	
15	8ES-14431-00	SILENCER, INTAKE 1	1	1	
16	8ES-14441-00	SILENCER, INTAKE 2	1	1	
17	8FN-14472-00	PLATE, ELEMENT	1	1	
18	8ES-14451-00	ELEMENT, AIR CLEANER	1	1	
19	8FA-14436-00	HOOK	4	4	
20	8ES-14425-00	DAMPER 1	2	2	
21	8ES-14452-00	SEAL	1	1	
22	8ES-1441A-00	COVER, CLEANER CASE 1	1	1	
23	8ES-14419-00	PIPE	1	1	
24	8ES-14453-00	JOINT, AIR CLEANER 1	3	3	
25	90450-67003	HOSE CLAMP ASSY	3	3	

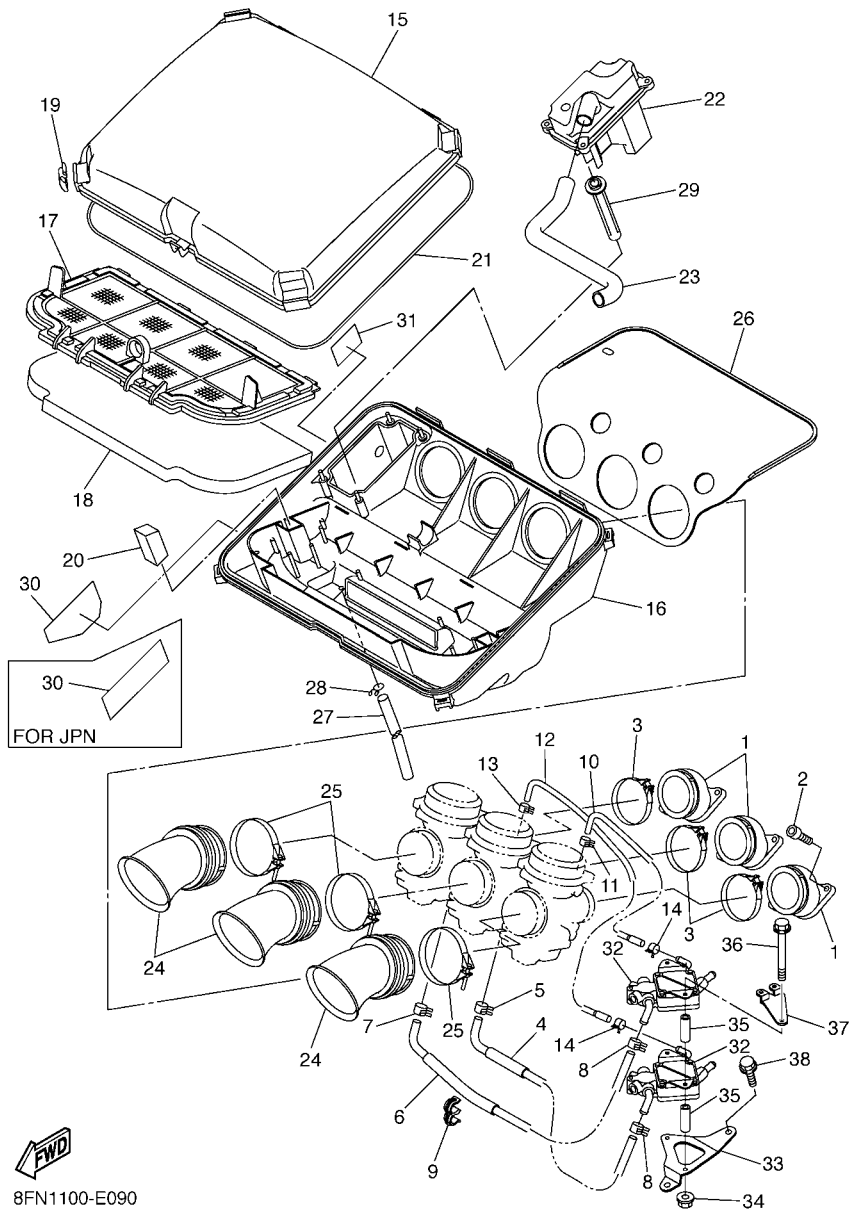

8FN1100-E090

FIG. 9 INTAKE

REF. NO.	PART NO.	DESCRIPTION	8/JE2	8/JE1	REMARKS
26	8ES-14283-00	COVER, CARBURETOR 1	1	1	
27	90445-11M52	HOSE (L150)	1	1	
28	90467-10041	CLIP	1	1	
29	8ES-14148-00	PIPE	1	1	
30	8GS-2815J-E0	LABEL, NOTICE BREATHER PIPE	1		
	8GS-2815J-S0	LABEL, NOTICE BREATHER PIPE		1	UR FOR EUR,RUS
	8GS-2815J-J0	LABEL, NOTICE BREATHER PIPE		1	UR FOR JPN
31	8ES-14427-00	LABEL, INSTRUCTION	1	1	
32	8FA-13910-00	FUEL PUMP ASSY	2	2	
33	8FA-24491-00	BRACKET, FUEL PUMP	1	1	
34	95702-06500	NUT, FLANGE	2	2	
35	90387-065V0	COLLAR	4	4	
36	95022-06085	BOLT, FLANGE	2	2	
37	8FN-12443-00	STAY	1	1	
38	95822-06016	BOLT, FLANGE	2	2	

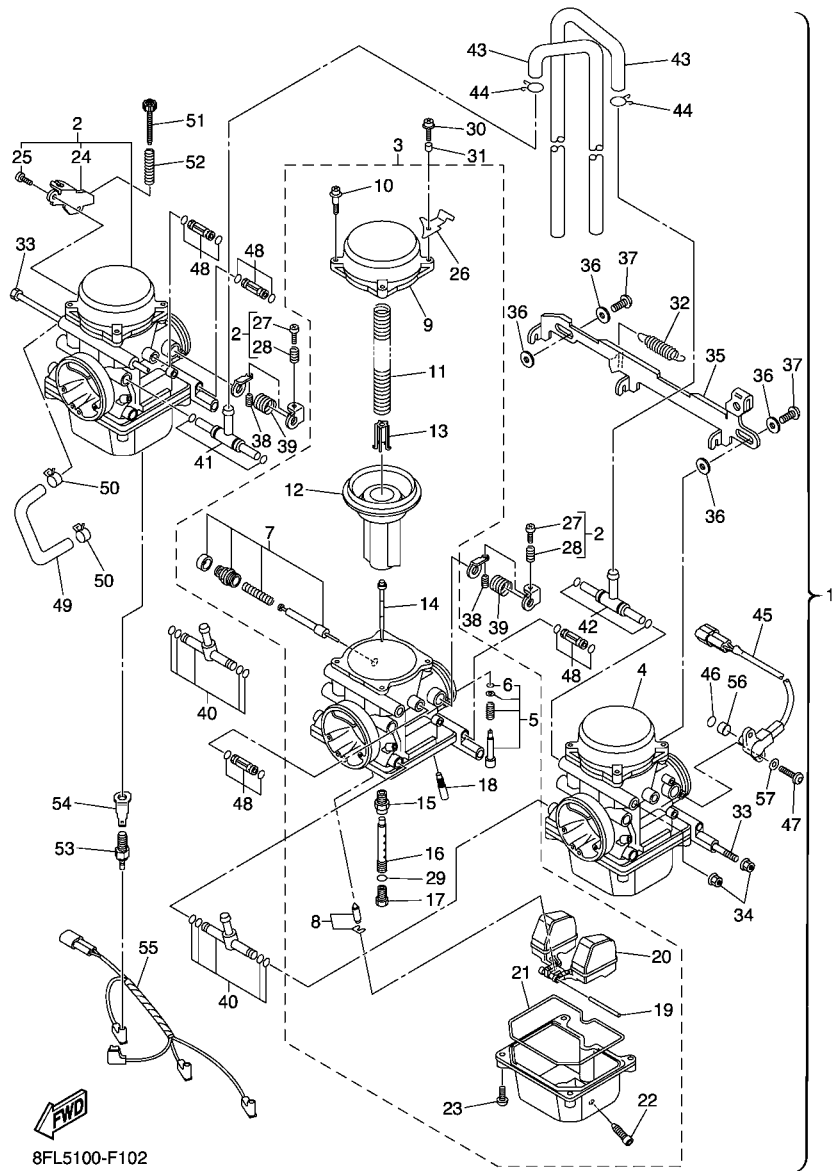

8FL5100-F102

FIG. 10 CARBURETOR

REF. NO.	PART NO.	DESCRIPTION	8/E2	8/E1		REMARKS
1	8ES-14900-02	CARBURETOR ASSY	1	1		
2	8ES-14901-01	.CARBURETOR ASSY 1	1	1		
3	8ES-14902-01	.CARBURETOR ASSY 2	1	1		
4	8ES-14903-01	.CARBURETOR ASSY 3	1	1		
5	8ES-14105-00	..PILOT SCREW SET	1	1		
6	8ES-14147-00	..O-RING	1	1		
7	8ES-1410A-00	..STARTER SET	1	1		
8	8ES-14107-00	..NEEDLE VALVE SET	1	1		
9	8ES-14958-00	..COVER, DIAPHRAGM	1	1		
10	4JH-14216-00	..SCREW	4	4		#1,3
	4JH-14216-00	..SCREW	3	3		#2
11	8ES-14933-00	..SPRING, DIAPHRAGM	1	1		
12	8ES-14940-00	..DIAPHRAGM ASSY	1	1		
13	4JH-14936-00	..SEAT, SPRING	1	1		
14	8ES-14916-00	..JET NEEDLE COMP.	1	1		
15	8ES-14947-00	..JET, NEEDLE	1	1		
16	8ES-1414G-00	..PIPE, MAIN BLEED	1	1		
17	3TJ-14943-87	..JET, MAIN (#148)	1	1		STD
	3TJ-14943-36	..JET, MAIN (#145)	1	1		AP
	3TJ-14943-37	..JET, MAIN (#150)	1	1		AP
18	8ES-14948-05	..JET (#45)	1	1		STD
	8ES-14948-03	..JET (#40)	1	1		AP
	8ES-14948-06	..JET (#48)	1	1		AP
	8ES-14948-07	..JET (#50)	1	1		AP
19	676-14548-00	..PIN, FLOAT ARM	1	1		
20	8ES-14985-00	..FLOAT	1	1		
21	8ES-14984-00	..GASKET, FLOAT CHAMBER	1	1		

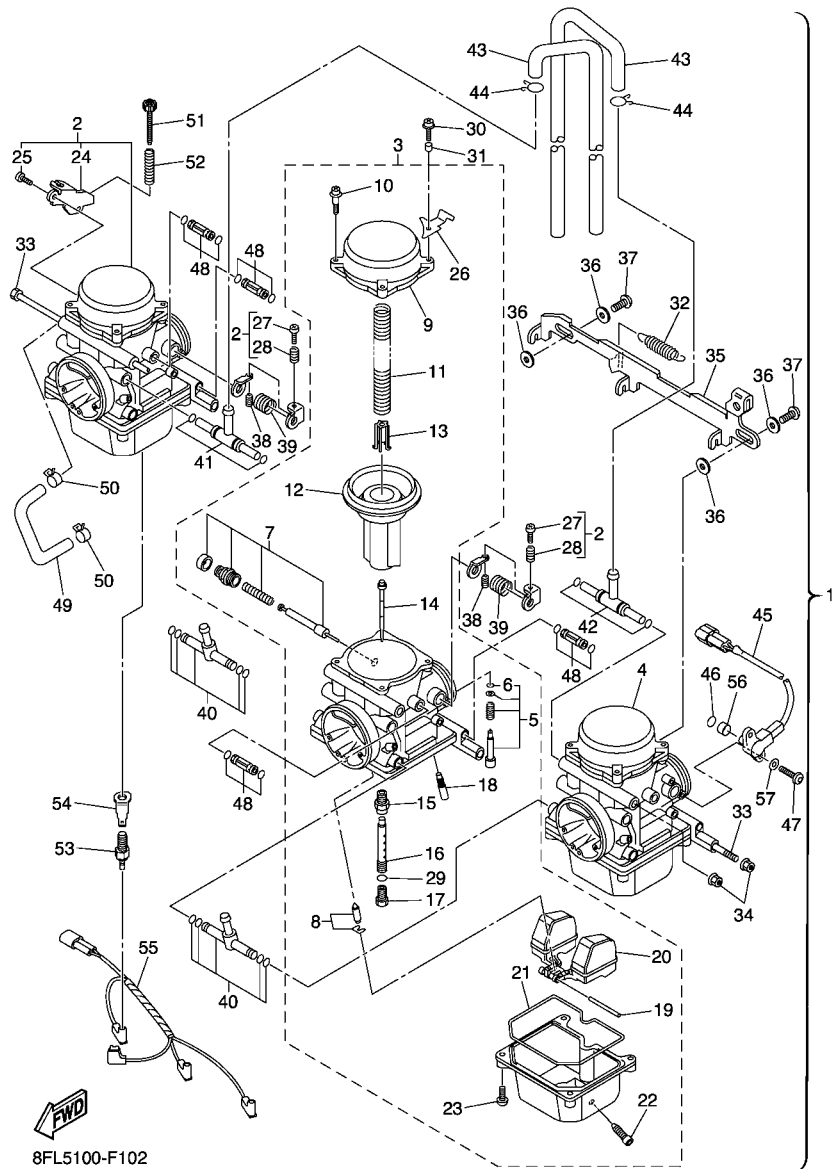

8FL5100-F102

FIG. 10 CARBURETOR

REF. NO.	PART NO.	DESCRIPTION	QTY	QTY	REMARKS
22	3TJ-14191-40	..PLUG, DRAIN	1	1	
23	98502-04014	..SCREW, PAN HEAD	4	4	
24	8ES-14926-01	..BRACKET, THROTTLE 1	1	1	#1
25	8ES-14592-00	..SCREW	1	1	#1
26	4TV-14926-00	..BRACKET, THROTTLE 1	1	1	#2
27	4JH-14121-00	..SCREW, THROTTLE STOP	1	1	#1,2
28	7A9-14555-00	..SPRING	1	1	#1,2
29	8ES-14561-00	..O-RING	1	1	
30	8ES-14565-00	.SCREW	1	1	
31	4JH-14264-00	.COLLAR	1	1	
32	8ES-14935-00	.SPRING	1	1	
33	8ES-14162-00	.BOLT, HOLDING	2	2	
34	4JH-14358-00	.NUT	2	2	
35	8ES-14965-00	.LEVER, STARTER	1	1	
36	8ES-14578-00	.COLLAR	4	4	
37	8ES-14567-00	.SCREW	2	2	
38	4YR-14133-00	.SPRING, THROTTLE STOP	2	2	
39	4JH-14487-00	.SPRING	2	2	
40	8ES-14295-00	.PIPE, FUEL	2	2	
41	8ES-13815-00	.JOINT 1	1	1	
42	8ES-13816-00	.JOINT 2	1	1	
43	8ES-14197-01	.PIPE	2	2	
44	3TJ-14937-40	.CLIP	2	2	
45	8ES-85885-01	.THROTTLE SENSOR ASSY	1	1	
46	4TV-14562-00	.O-RING	1	1	
47	4YR-14216-00	.SCREW	2	2	
48	8ES-14454-00	.JOINT	4	4	

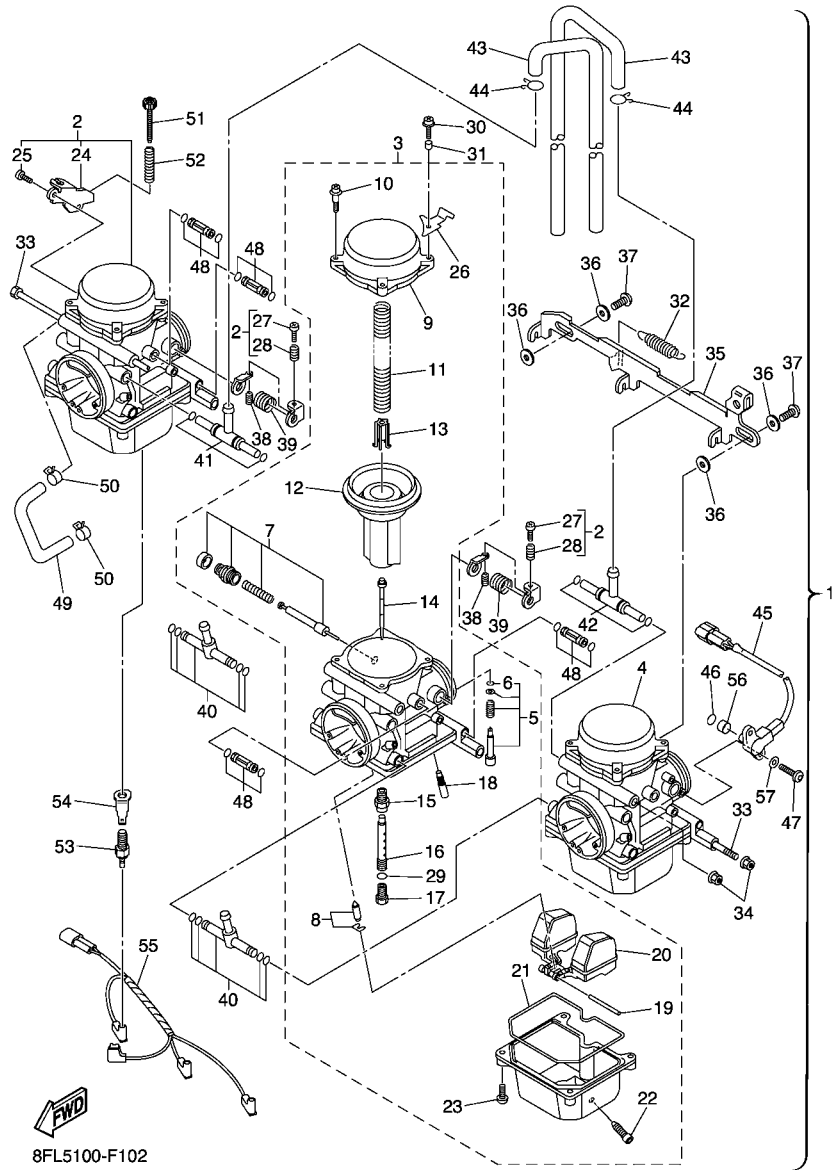
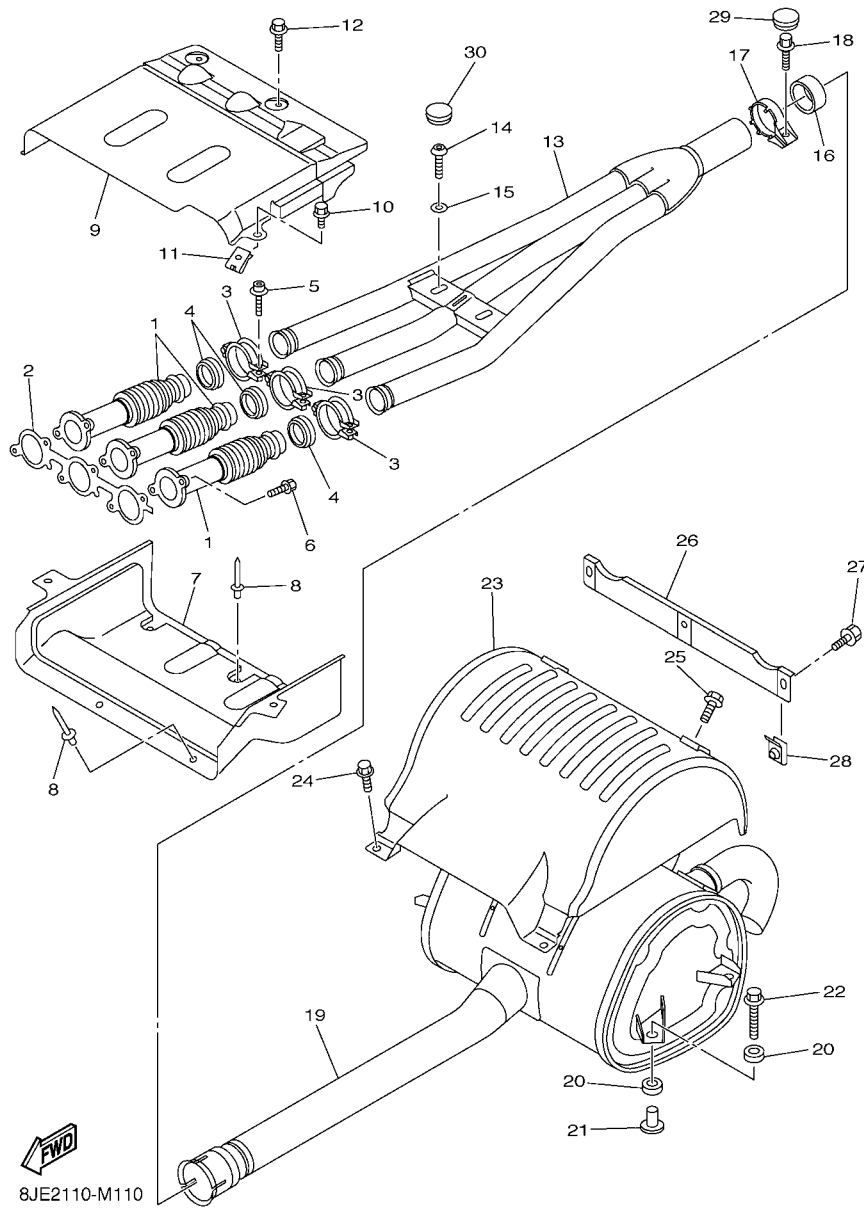

FIG. 10 CARBURETOR

REF. NO.	PART NO.	DESCRIPTION	QTY	REMARKS
49	8ES-14987-00	.HOSE	1	
50	4TV-12486-00	.CLIP	2	
51	8ES-14121-00	.SCREW, THROTTLE STOP	1	
52	4YR-14934-00	.SPRING, THROTTLE STOP	1	
53	5FU-83790-20	.HEATER ASSY (30W)	3	
54	8FA-82103-00	.TERMINAL 1	1	
55	8ES-81517-01	.WIRE, SUB LEAD	1	
56	4TV-14534-00	.COLLAR	1	
57	4YR-14557-00	.WASHER	2	



8JE2110-M110

FIG. 11 EXHAUST

REF. NO.	PART NO.	DESCRIPTION	8JE2	8JE1	REMARKS
1	8ES-14615-01	JOINT, EXHAUST 1	3	3	
2	8ES-14613-00	GASKET, EXHAUST PIPE	1	1	
3	8FA-14715-00	BAND, MUFFLER	3	3	
4	8FA-14623-10	GASKET, EXHAUST PIPE	3	3	
5	90109-06031	BOLT	3	3	
6	95022-08020	BOLT, FLANGE	6	6	
7	8ES-14627-00	COVER, EXHAUST	1	1	
8	90267-47195	RIVET, BLIND(4.7X16.4 YELLOW)	3	3	
9	8FN-14637-00	EXHAUST COVER ASS'Y	1	1	
10	95812-06008	BOLT, FLANGE	2	2	
11	90183-060A0	NUT, SPRING	2	2	
12	95812-06016	BOLT, FLANGE	2	2	
13	8ES-14610-00	EXHAUST PIPE ASSY 1	1	1	
14	92012-08025	BOLT, BUTTON HEAD	2	2	
15	92990-08200	WASHER, PLAIN	2	2	
16	8FA-14714-10	GASKET, MUFFLER	1	1	
17	8FA-14788-00	BAND, SILENCER	1	1	
18	95812-08020	BOLT, FLANGE	1	1	
19	8FN-14750-00	SILENCER ASSY	1	1	
20	8FA-14737-00	DAMPER, MUFFLER	8	8	
21	90387-08071	COLLAR	4	4	
22	90119-08112	BOLT, WITH WASHER	4	4	
23	8JE-14708-00	PROTECTOR ASSY	1	1	
24	90119-06179	BOLT, WITH WASHER	2	2	
25	95812-06008	BOLT, FLANGE	2	2	
26	8ES-1478N-00	PLATE, 8	1	1	
27	95812-06008	BOLT, FLANGE	3	3	

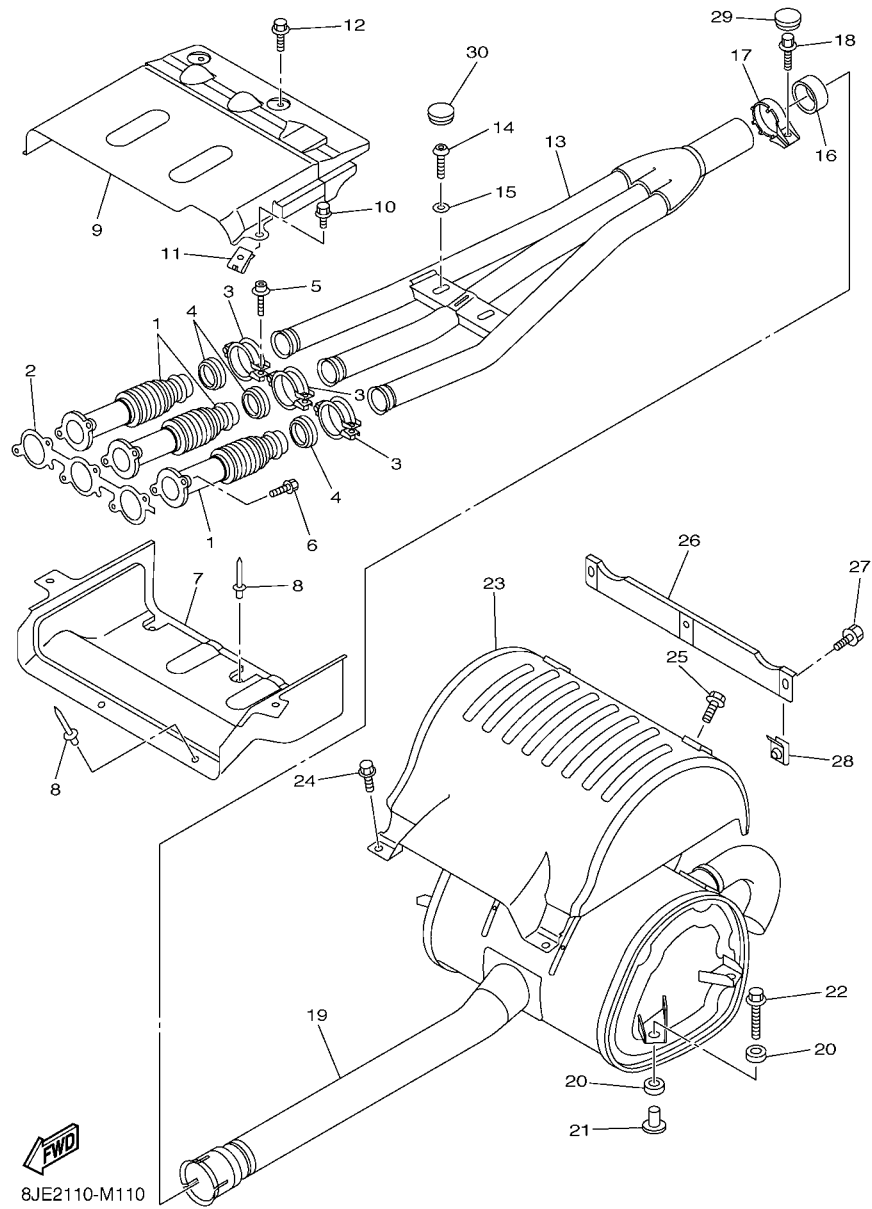

8JE2110-M110

FIG. 11 EXHAUST

REF. NO.	PART NO.	DESCRIPTION	8JE2	8JE1	REMARKS
28	90183-060A0	NUT, SPRING	3	3	
29	90338-20004	PLUG	1	1	
30	90338-20007	PLUG	2	2	

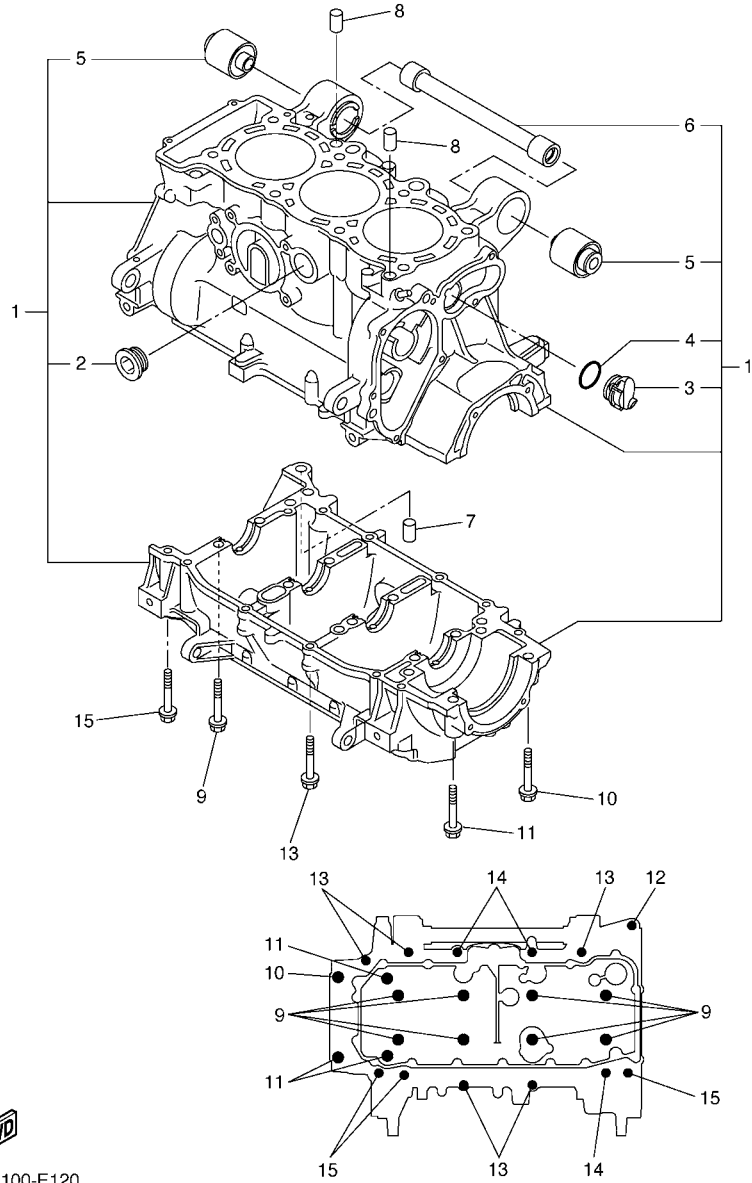

FWD
8FJ3100-E120

FIG. 12 CRANKCASE

REF. NO.	PART NO.	DESCRIPTION	QTY	QTY		REMARKS
1	8ES-15100-08	CRANKCASE ASSY	1	1		
2	90340-27129	.PLUG, STRAIGHT SCREW	1	1		
3	8ES-15167-00	.PLUG, BLIND 1	1	1		
4	93210-24709	.O-RING	1	1		
5	8FA-2139X-00	.DAMPER	2	2		
6	8ES-21459-00	.SPACER	1	1		
7	99530-10014	PIN, DOWEL	1	1		
8	99530-10114	PIN, DOWEL	2	2		
9	90119-09004	BOLT, WITH WASHER	8	8		
10	95812-08055	BOLT, FLANGE	1	1		
11	95812-08070	BOLT, FLANGE	3	3		
12	90109-06185	BOLT	1	1		
13	95812-06055	BOLT, FLANGE	5	5		
14	95812-06080	BOLT, FLANGE	3	3		
15	90105-06123	BOLT, FLANGE	3	3		



8ES1100-D130

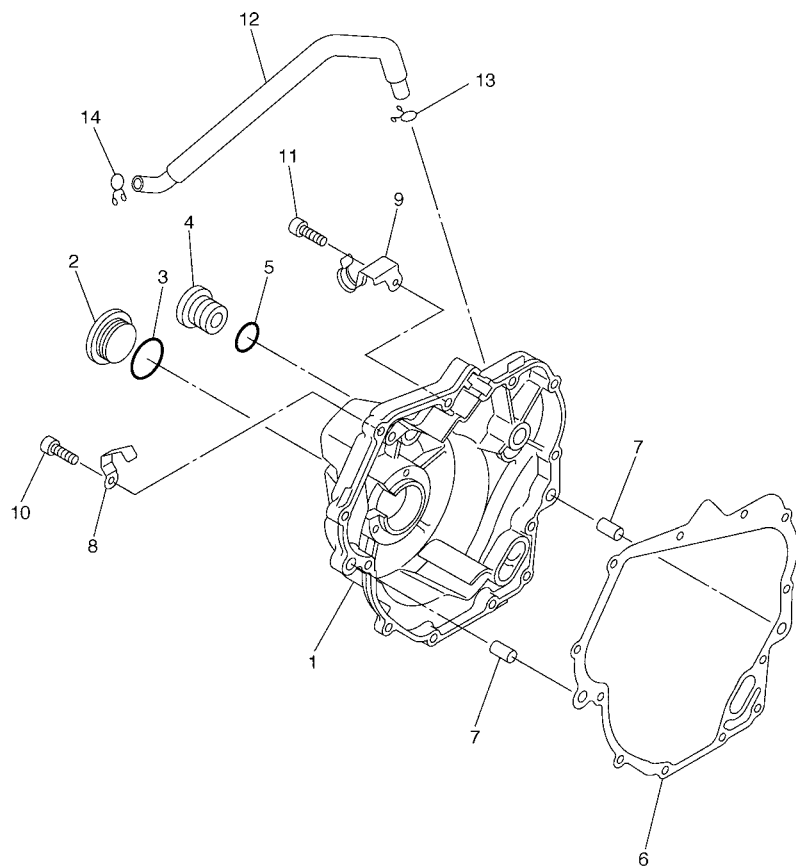
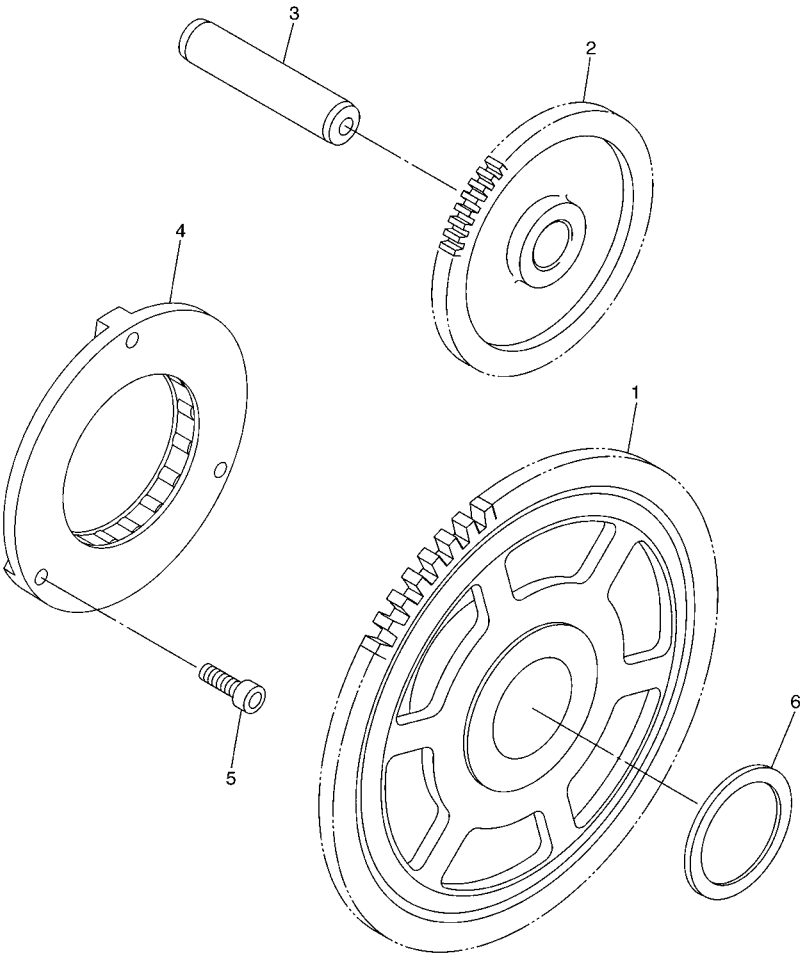

FIG. 13 CRANKCASE COVER 1

REF. NO.	PART NO.	DESCRIPTION	8/E2	8/E1		REMARKS
1	8ES-15421-01	COVER, CRANKCASE 2	1	1		
2	90340-32080	PLUG, STRAIGHT SCREW	1	1		
3	93210-32172	O-RING	1	1		
4	90340-14117	PLUG, STRAIGHT SCREW	1	1		
5	93210-14369	O-RING	1	1		
6	8ES-15461-01	GASKET, CRANKCASE COVER 2	1	1		
7	99530-08012	PIN, DOWEL	2	2		
8	90462-08225	CLAMP	1	1		
9	90465-10038	CLAMP	1	1		
10	90109-06015	BOLT	11	11		
11	90110-06234	BOLT, HEXAGON SOCKET HEAD	1	1		
12	8ES-1531A-00	HOSE, BREATHER 1	1	1		
13	90467-100A1	CLIP	1	1		
14	90467-11019	CLIP	1	1		

FIG. 14 STARTER

REF. NO.	PART NO.	DESCRIPTION	8/JE2	8/JE1			REMARKS
1	8FA-15515-00	GEAR 3	1	1			
2	8ES-15512-01	GEAR, IDLER 1	1	1			
3	8ES-15521-00	SHAFT 1	1	1			
4	8GL-15590-00	STARTER ONE-WAY ASSY	1	1			
5	90110-06168	BOLT, HEXAGON SOCKET HEAD	3	3			
6	90201-30013	WASHER, PLATE	1	1			



8GM1100-G140

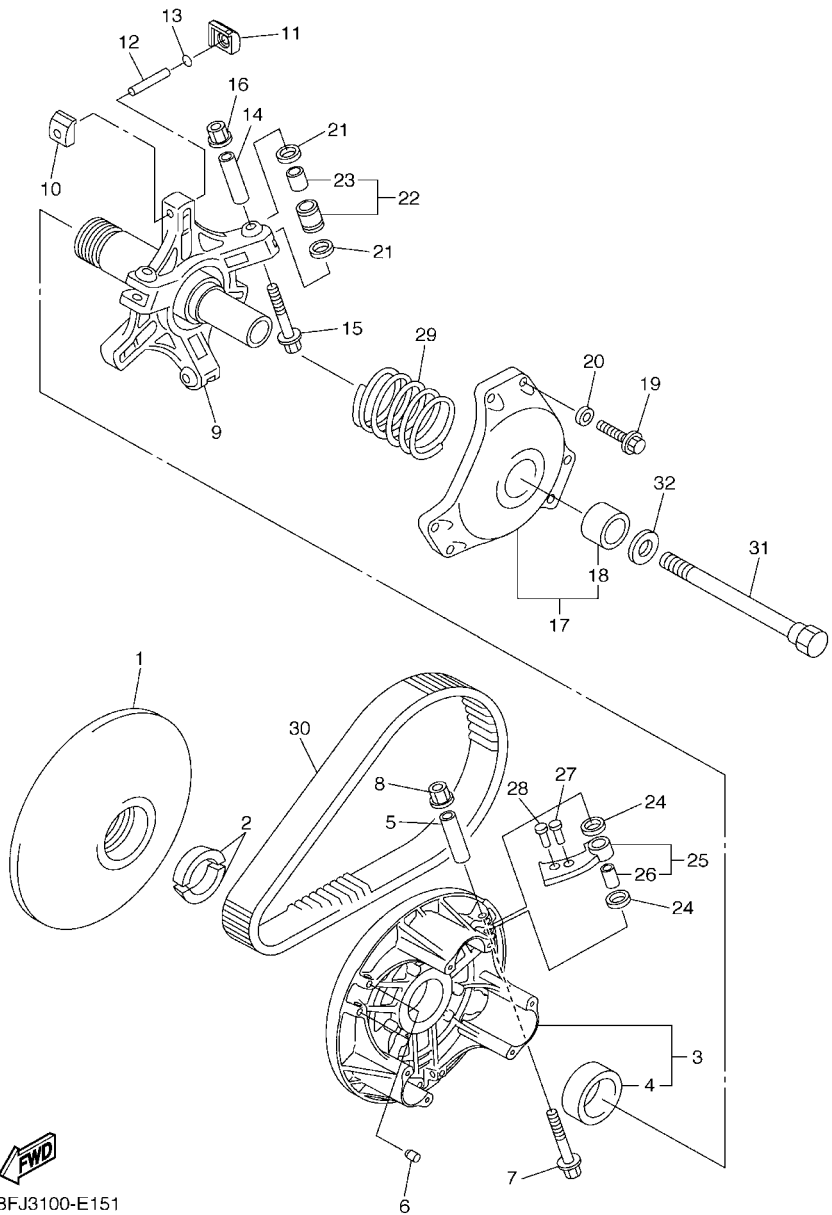

8FJ3100-E151

FIG. 15 PRIMARY SHEAVE

REF. NO.	PART NO.	DESCRIPTION	8/E2	8/E1		REMARKS
1	8FA-17611-01	SHEAVE, PRIMARY FIXED	1	1		
2	8V0-17639-00	STOPPER	2	2		
3	8FP-17620-00	PRIMARY SLIDING SHEAVE COMP.	1	1		
4	90384-41242	.BUSH, BIMETAL FORMED	1	1		
5	90387-0514T	COLLAR	3	3		
6	90113-05053	BOLT, SET	6	6		
7	90105-05644	BOLT, FLANGE	3	3		
8	95602-05200	NUT, SELF-LOCKING	3	3		
9	8ES-17640-02	SPIDER COMPLETE	1	1		
10	8BW-17653-00	SLIDER	3	3		
11	8ES-17653-00	SLIDER	3	3		
12	91609-50032	PIN, SPRING	3	3		
13	8ES-17655-00	DAMPER, SLIDER	3	3		
14	90387-0514U	COLLAR	3	3		
15	90105-05644	BOLT, FLANGE	3	3		
16	95602-05200	NUT, SELF-LOCKING	3	3		
17	8DF-17630-00	PRIMARY SHEAVE CAP COMP.	1	1		
18	90380-28237	.BUSH, SOLID	1	1		
19	97017-06030	BOLT	6	6		
20	92907-06600	WASHER, PLATE	6	6		
21	90202-09227	WASHER, PLATE	6	6		
22	8FG-17624-20	ROLLER, COMP	3	3		
23	90386-09001	.BUSH	1	1		
24	90202-08204	WASHER, PLATE	6	6		
25	8FN-17605-00	WEIGHT COMP	3	3		
26	90386-08002	.BUSH	1	1		
27	90269-06006	RIVET (ST17.2MM)	3	3		IN

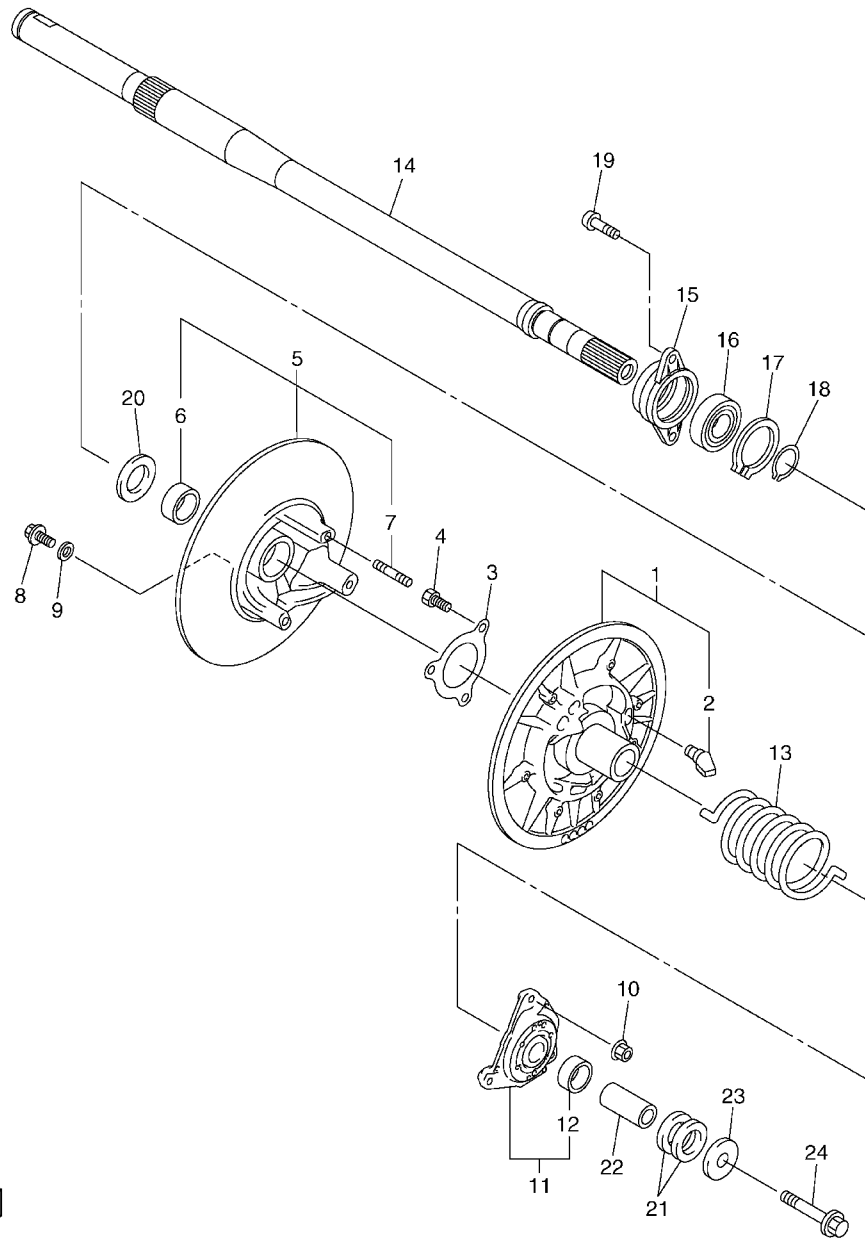
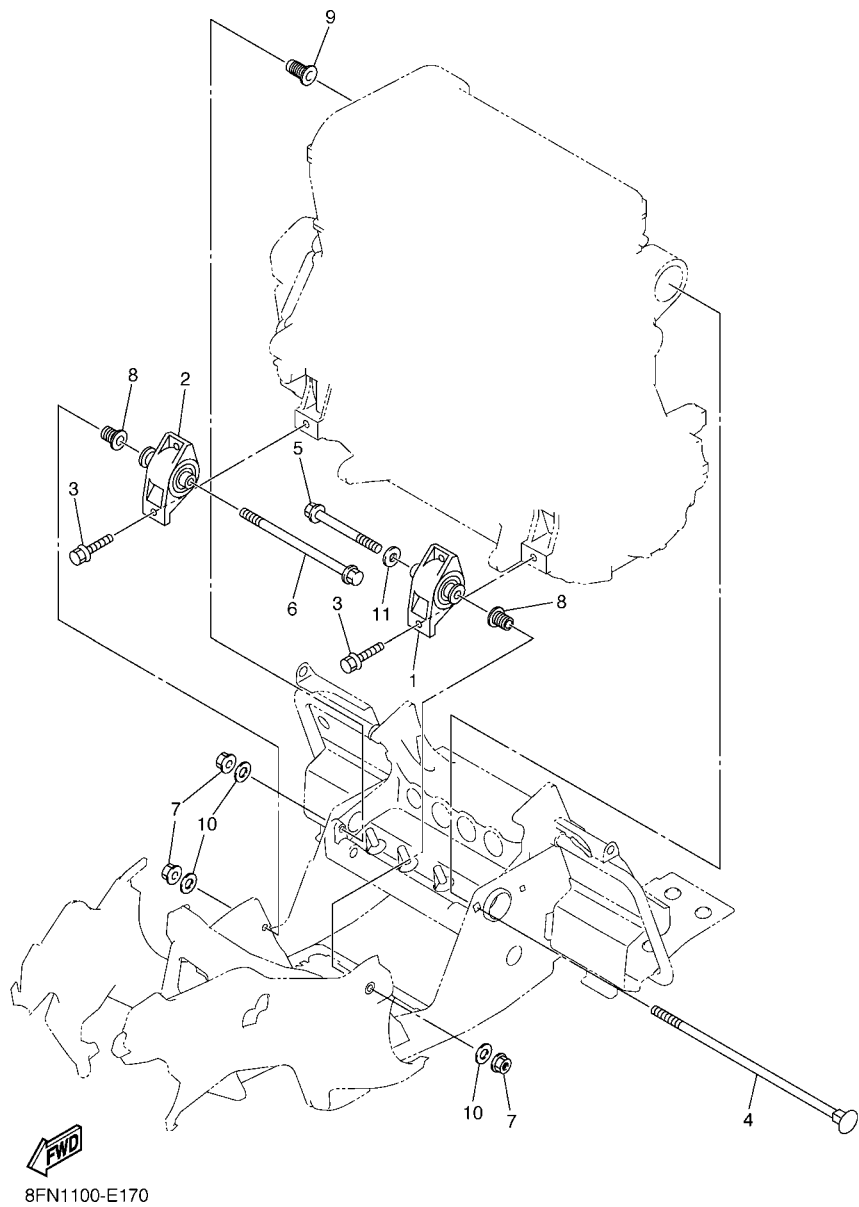

FIG. 16 SECONDARY SHEAVE

REF. NO.	PART NO.	DESCRIPTION	8JE2	8JE1	REMARKS
1	8CR-17660-30	SECONDARY FIXED SHEAVE COMP.	1	1	
2	8AV-17688-10	.SHOE, RAMP	3	3	
3	8BV-17656-00	STOPPER, HOLDER	1	1	
4	90154-06062	SCREW, BINDING	3	3	
5	8BU-17670-30	SECONDARY SLIDING SHEAVE	1	1	
6	90384-38243	.BUSH, BIMETAL FORMED	1	1	
7	95617-08630	.BOLT, STUD	3	3	
8	90105-06734	BOLT, FLANGE	3	3	
9	90201-06037	WASHER, PLATE (T=1.0)	3	3	UR UN
	90201-061H1	WASHER, PLATE (T=0.5)	3	3	UR UN
10	90179-08655	NUT	3	3	
11	8BV-17604-91	SEAT SPRING SET	1	1	
12	90384-38243	.BUSH, BIMETAL FORMED	1	1	
13	90508-60018	SPRING, TORSION	1	1	(P-P)
14	8GS-17681-02	SHAFT, SECONDARY	1	1	
15	8FN-47631-00	HOUSING, BEARING	1	1	
16	93306-30579	BEARING	1	1	
17	99009-62500	CIRCLIP	1	1	
18	99009-25400	CIRCLIP	1	1	
19	90149-08034	SCREW	2	2	
20	90201-25526	WASHER, PLATE (T2.0)	2	2	UN
21	90201-225A4	WASHER, PLATE (T=1.0)	3	3	UR UN
	90201-222F0	WASHER, PLATE (T=0.5)	1	1	UR UN
22	90387-14019	COLLAR	1	1	
23	90201-141A3	WASHER, PLATE	1	1	
24	90105-14766	BOLT, FLANGE	1	1	



8GS1100-F161



8FN1100-E170

FIG. 17 ENGINE BRACKET

REF. NO.	PART NO.	DESCRIPTION	8/E2	8/E1	REMARKS
1	8ES-21410-00	ENGINE BRACKET COMP.	1	1	
2	8ES-21420-00	ENGINE BRACKET COMP. 2	1	1	
3	95812-08030	BOLT, FLANGE	4	4	
4	8FN-21481-01	BOLT, ENGINE MOUNTING 1	1	1	
5	95817-12100	BOLT, FLANGE	1	1	
6	95817-12200	BOLT, FLANGE	1	1	
7	90179-12004	NUT	3	3	
8	8FG-21495-00	BOLT, ENGINE ADJUSTING	2	2	
9	8FG-2149C-00	BOLT	1	1	
10	90201-120T5	WASHER, PLATE	3	3	
11	90201-125A3	WASHER, PLATE	1	1	

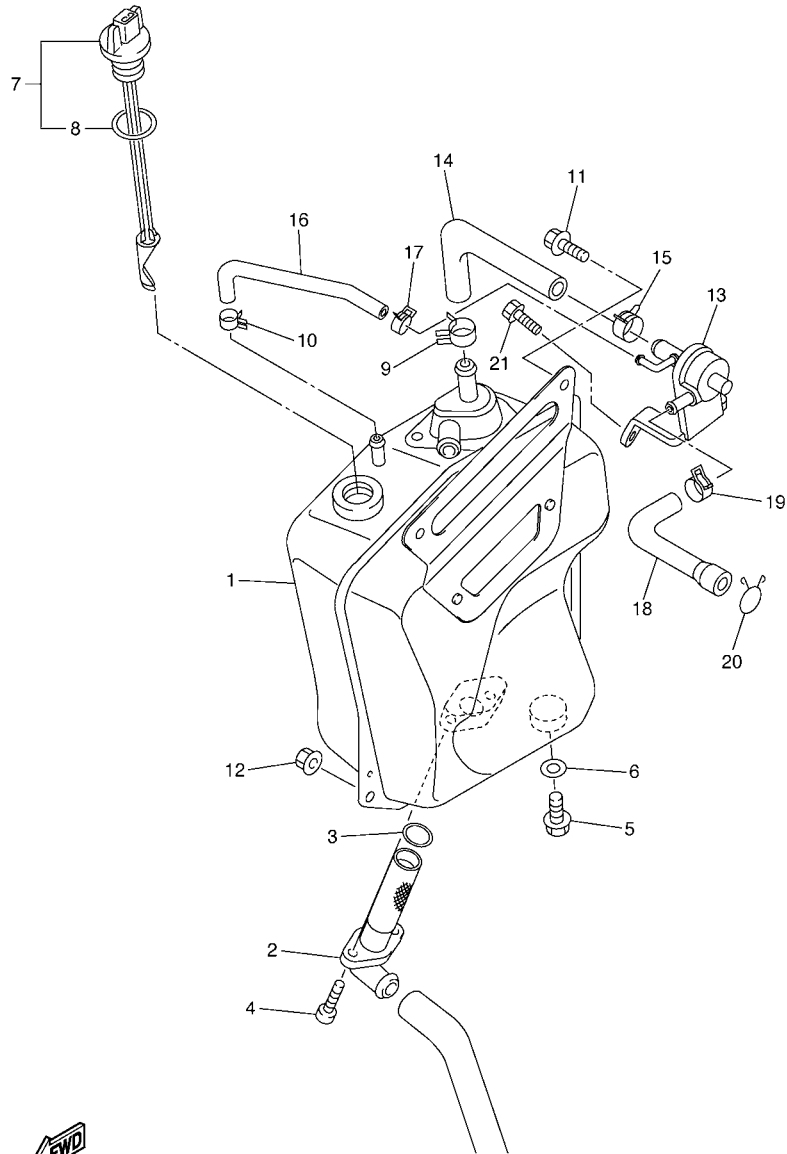

8FN1100-E180

FIG. 18 OIL TANK

REF. NO.	PART NO.	DESCRIPTION	QTY	QTY	REMARKS
1	8FG-21751-02	TANK, OIL	1	1	
2	8FG-13406-00	OIL PIPE COMP. 2	1	1	
3	93210-19026	O-RING	1	1	
4	91317-06016	BOLT	2	2	
5	95807-08012	BOLT, FLANGE	1	1	
6	90430-08204	GASKET	1	1	
7	8FA-85720-01	OIL LEVEL GAUGE ASSY	1	1	
8	8FP-85075-00	.O-RING	1	1	
9	90468-08104	CLIP	1	1	
10	90467-12053	CLIP	1	1	
11	95812-06016	BOLT, FLANGE	2	2	
12	95602-08200	NUT, SELF-LOCKING	1	1	
13	8FN-13520-00	VALVE ASSY.	1	1	
14	8ES-21745-00	PIPE, OIL TANK BREATHER	1	1	
15	90468-08104	CLIP	1	1	
16	8ES-2174N-00	PIPE, OIL TANK	1	1	
17	90467-12053	CLIP	1	1	
18	8FN-21816-00	PIPE 1	1	1	
19	90467-20085	CLIP	1	1	
20	90467-22080	CLIP	1	1	
21	95822-06020	BOLT, FLANGE	2	2	

FIG. 19 FRAME

REF. NO.	PART NO.	DESCRIPTION	8JE2	8JE1	REMARKS
1	8GS-21940-12	FRONT FRAME COMP.	1	1	
2	8FN-2191A-09	.BULKHEAD	1	1	
3	90381-15001	..BUSH, SOLID	2	2	
4	90381-16004	..BUSH, SOLID	2	2	
5	8FN-Y291E-02	.BULKHEAD 2	1	1	
6	90381-15001	..BUSH, SOLID	2	2	
7	90381-16004	..BUSH, SOLID	2	2	
8	90105-08072	.BOLT, FLANGE	4	4	
9	95607-08200	.NUT, SELF-LOCKING	4	4	
10	8FN-21947-00	.BRACKET, STEERING 1	1	1	
11	95607-10200	.NUT, U FLANGE	4	4	
12	8GS-2193A-01	.PROTECTOR	1	1	
13	90267-47195	.RIVET, BLIND(4.7X16.4 YELLOW)	57	57	
14	90267-48016	.RIVET, BLIND (4.8X16.4 YELLOW)	21	21	
15	8FN-2198E-00	.REINFORCEMENT, FRAME 3	1	1	
16	8FN-2194F-00	.BRACKET, ENGINE 2	1	1	
17	8FN-2194G-00	.BRACKET, ENGINE 3	1	1	
18	90267-48176	.RIVET, BLIND (4.8X17 YELLOW)	2	2	
19	90267-48177	.RIVET, BLIND (4.8X14 YELLOW)	1	1	
20	8JE-21950-00	REAR FRAME COMP.	1	1	
21	90267-48023	.RIVET, BLIND(4.8X12.1 YELLOW)	41	41	
22	90267-48177	.RIVET, BLIND (4.8X14 YELLOW)	39	39	
23	8JE-21944-00	.BRACKET,RR.TRACK SUSPENTION 1	1	1	
24	8JE-21954-00	.BRACKET,RR.TRACK SUSPENTION 2	1	1	
25	90176-10033	.NUT, CROWN	6	6	
26	8FN-2194H-00	.PROTECTOR, MUFFLER	1	1	
27	8FN-21926-00	.REINFORCEMENT, FOOTREST 1	1	1	

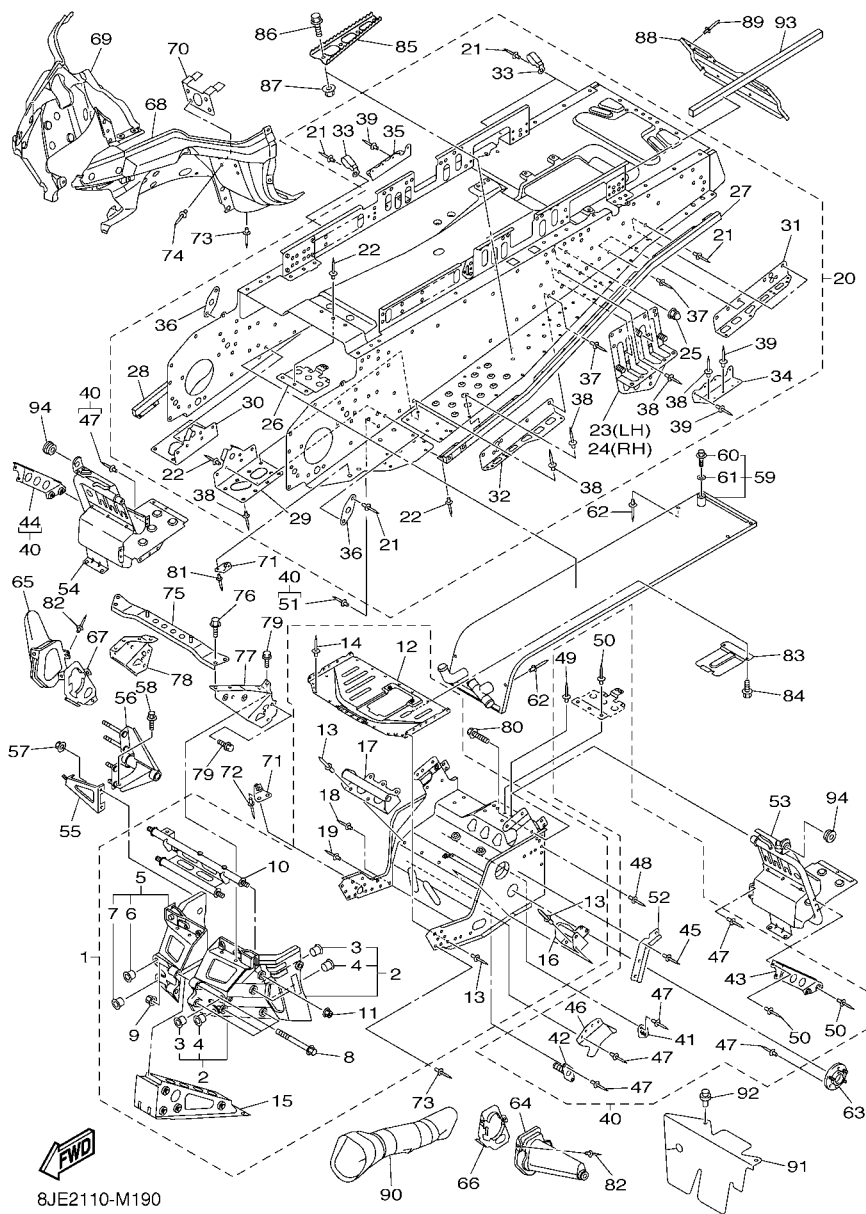
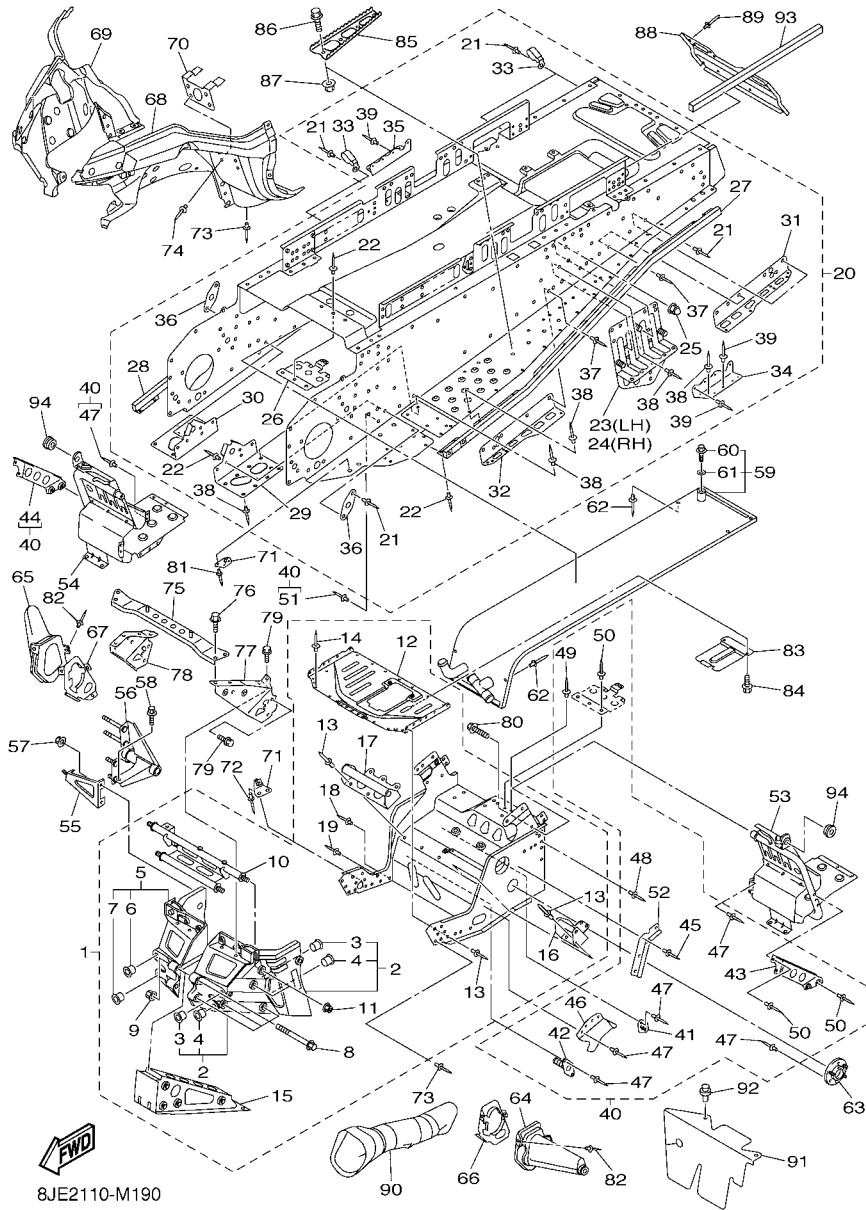

FIG. 19 FRAME

REF. NO.	PART NO.	DESCRIPTION	8JE2	8JE1	REMARKS
28	8FN-21936-00	.REINFORCEMENT, FOOTREST 2	1	1	
29	8JE-21943-00	.BRACKET, MAIN TRACK 1	1	1	
30	8JE-21953-00	.BRACKET, MAIN TRACK 2	1	1	
31	8FN-21962-01	.PATCH 2	2	2	
32	8FN-21963-01	.PATCH 3	2	2	
33	90465-08368	.CLAMP	7	7	
34	8GS-21965-10	.PATCH 5	1	1	
35	8GS-21966-10	.PATCH 6	1	1	
36	8FN-21953-00	.BRACKET, MAIN TRACK 2	2	2	
37	90267-48026	.RIVET, BLIND	48	48	
38	90267-48028	.RIVET, BLIND	68	68	
39	90267-48029	.RIVET, BLIND	16	16	
40	8JE-W2195-00	FRAME CONNECTION KIT	1	1	
41	8CR-21939-01	.BRACKET, CHAIN HOUSING	1	1	
42	8FN-21939-00	.BRACKET, CHAIN HOUSING	1	1	
43	8FG-2196M-00	.BRACKET, 5	1	1	
44	8FG-2197M-00	.BRACKET, 6	1	1	
45	90267-48018	.RIVET, BLIND (4.8X18.6 BLACK)	4	4	
46	8FU-2198G-00	.COVER 2	1	1	
47	90267-47195	.RIVET, BLIND(4.7X16.4 YELLOW)	44	44	
48	90267-48016	.RIVET, BLIND (4.8X16.4 YELLOW)	6	6	
49	90267-48023	.RIVET, BLIND(4.8X12.1 YELLOW)	6	6	
50	90267-48177	.RIVET, BLIND (4.8X14 YELLOW)	22	22	
51	90267-48176	.RIVET, BLIND (4.8X17 YELLOW)	2	2	
52	8FA-21999-00	.CLAMP, WIRE HARNESS	1	1	
53	8FN-21960-01	FOOTREST COMP. 1	1	1	
54	8GS-21970-00	FOOTREST COMP. 2	1	1	



8JE2110-M190

FIG. 19 FRAME

REF. NO.	PART NO.	DESCRIPTION	QTY	QTY	REMARKS
55	8FN-2193E-00	BRACKET, OIL TANK 1	1	1	
56	8FN-2194E-00	BRACKET, ENGINE	1	1	
57	95602-08200	NUT, SELF-LOCKING	2	2	
58	95822-10016	BOLT, FLANGE	1	1	
59	8FN-12440-01	HEAT EXCHANGER ASSY	1	1	
60	95812-06016	.BOLT, FLANGE	1	1	
61	90210-06006	.WASHER, SEAL	1	1	
62	90267-48016	RIVET, BLIND (4.8X16.4 YELLOW)	8	8	
63	8EK-21920-01	HOUSING, REINF SUB-ASSY(L.H)	1	1	
64	8FU-2198F-01	COVER 1	1	1	
65	8FU-2198J-01	COVER 3	1	1	
66	8FU-2195E-01	PLATE, STRG BRACKET 1	1	1	
67	8FU-2195F-01	PLATE, STRG BRACKET 2	1	1	
68	8ES-2196A-01	FRAME UNDER 1	1	1	
69	8FA-2196E-01	FRAME, UNDER 2	1	1	
70	8FA-21972-01	BRACKET, GUARD FITTING	1	1	
71	8FA-2196F-00	BRACKET 3	6	6	
72	90267-48083	RIVET,BLIND (4.8X15.2 SILVER)	8	8	
73	90267-48018	RIVET, BLIND (4.8X18.6 BLACK)	14	14	
74	90267-47187	RIVET, BLIND (4.7X16.4 BLACK)	4	4	
75	8FN-77512-00	BUMPER, FRONT 2	1	1	
76	95822-06012	BOLT, FLANGE	4	4	
77	8FN-21949-00	BRACKET, FRONT	1	1	
78	8FN-21959-00	BRACKET, FRONT BUMPER	1	1	
79	95822-08016	BOLT, FLANGE	6	6	
80	95822-08020	BOLT, FLANGE	2	2	
81	90267-48095	RIVET,BLIND (4.8X12.6 SILVER)	4	4	

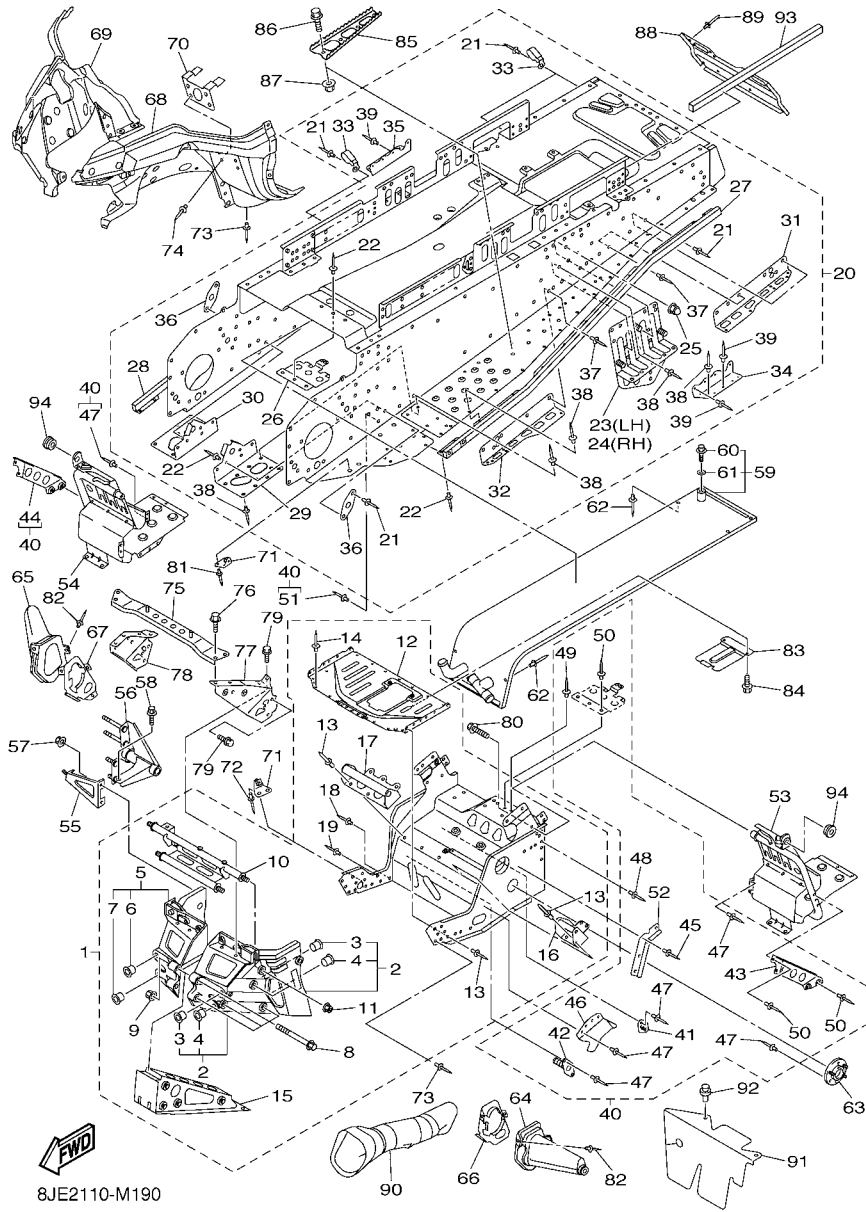

8JE2110-M190

FIG. 19 FRAME

REF. NO.	PART NO.	DESCRIPTION	QTY	QTY	REMARKS
82	90267-47195	RIVET, BLIND(4.7X16.4 YELLOW)	6	6	
83	8FR-2197E-00	PROTECTOR, FRAME FR	1	1	
84	92012-06012	BOLT, BUTTON HEAD	2	2	
85	8JE-27431-00	FOOTREST, REAR 1	2	2	
86	95807-06012	BOLT, FLANGE	8	8	
87	95707-06500	NUT, FLANGE	8	8	
88	8FN-21933-01	REINFORCEMENT, FRAME REAR 2	1	1	
89	90267-47195	RIVET, BLIND(4.7X16.4 YELLOW)	8	8	
90	8FN-21557-00	DUCT, AIR	1	1	
91	8FN-2198F-00	COVER 1	1	1	
92	90269-09002	RIVET	2	2	
93	8FN-241A5-00	SEAL 5	1	1	
94	90480-16278	GROMMET	2	2	

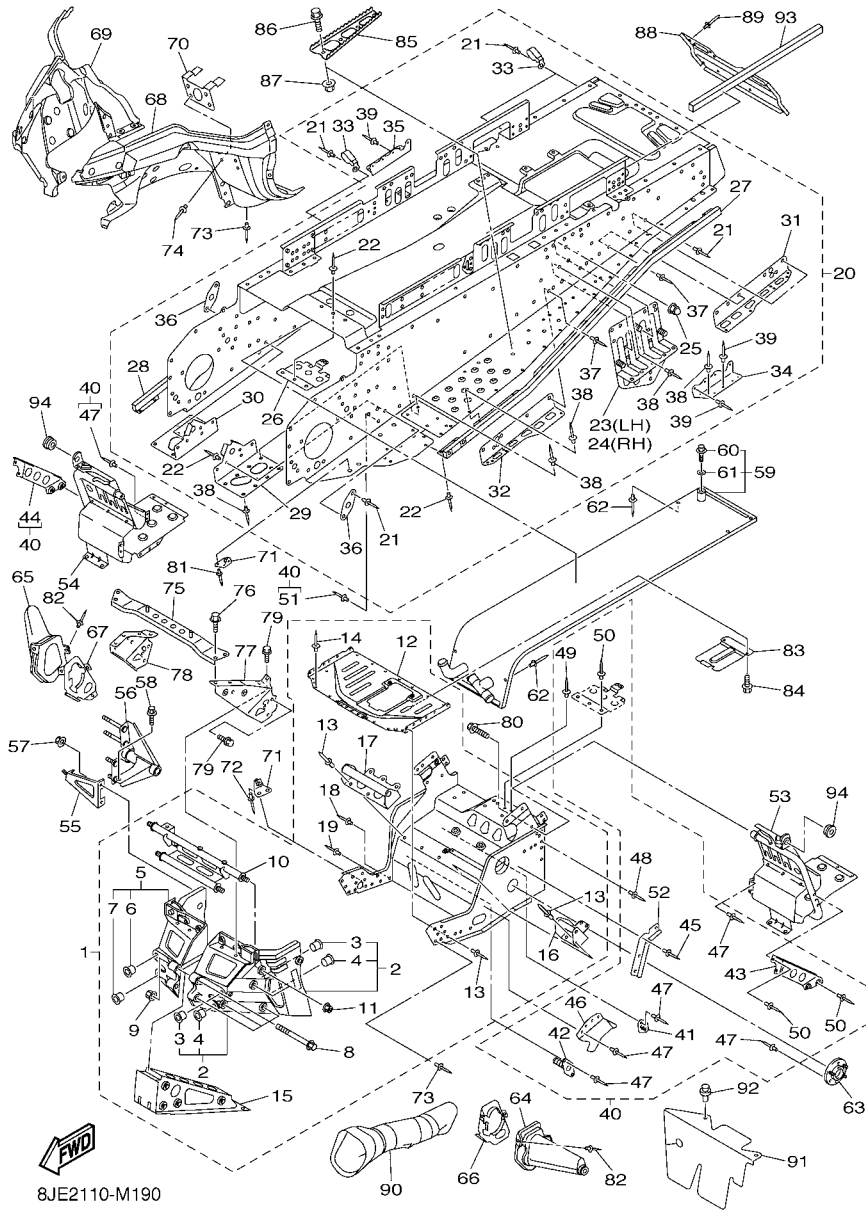

8JE2110-M190

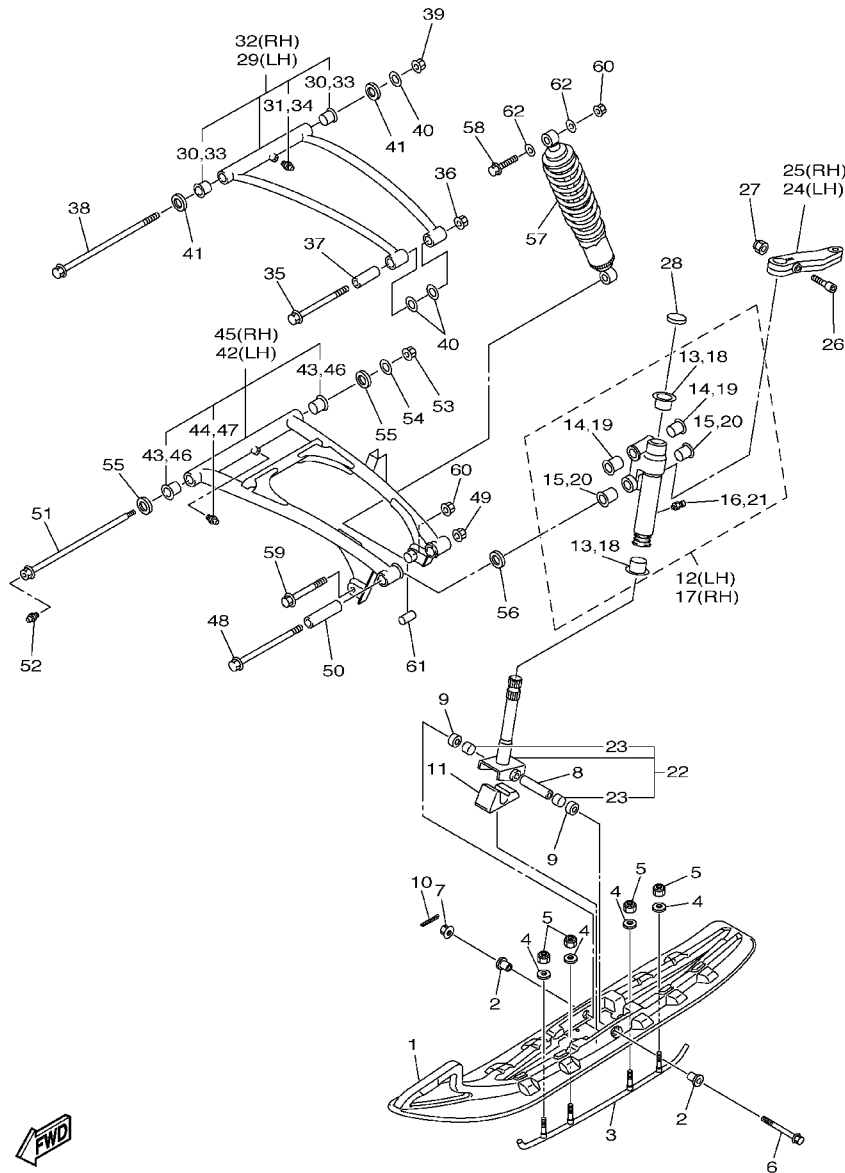

8JE2110-M201

FIG. 20 SKI

REF. NO.	PART NO.	DESCRIPTION	8JE2	8JE1	REMARKS
1	8JE-F3711-00	SKI	2		
	8JE-23711-00	SKI		2	
2	8HR-F3754-00	COLLAR, 1	2		
	8HR-23754-00	COLLAR, 1		2	
3	8JD-F3731-00	RUNNER 1	1		
	8JD-23731-00	RUNNER 1		1	
4	8HR-F3738-00	WASHER 2	4		
	8HR-23738-00	WASHER 2		4	
5	8HR-F3778-00	NUT	4		
	8HR-23778-00	NUT		4	
6	90105-10410	BOLT, FLANGE	2	2	
7	95602-10200	NUT, U FLANGE	2	2	
8	90387-1012H	COLLAR	2	2	
9	90387-10029	COLLAR	4	4	
10	91401-20020	PIN, COTTER	2	2	
11	8ES-23743-00	STOPPER 1	2	2	
12	8ES-23501-10	STEERING KNUCKLE ASSY (LEFT)	1	1	
13	90381-25115	.BUSH, SOLID	2	2	
14	90381-15N50	.BUSH, SOLID	2	2	
15	90381-18N51	.BUSH, SOLID	2	2	
16	93700-06004	.NIPPLE, GREASE	1	1	
17	8ES-23502-10	STEERING KNUCKLE ASSY (RIGHT)	1	1	
18	90381-25115	.BUSH, SOLID	2	2	
19	90381-15N50	.BUSH, SOLID	2	2	
20	90381-18N51	.BUSH, SOLID	2	2	
21	93700-06004	.NIPPLE, GREASE	1	1	
22	8ES-23803-00	COLUMN, SKI ASSY	2	2	

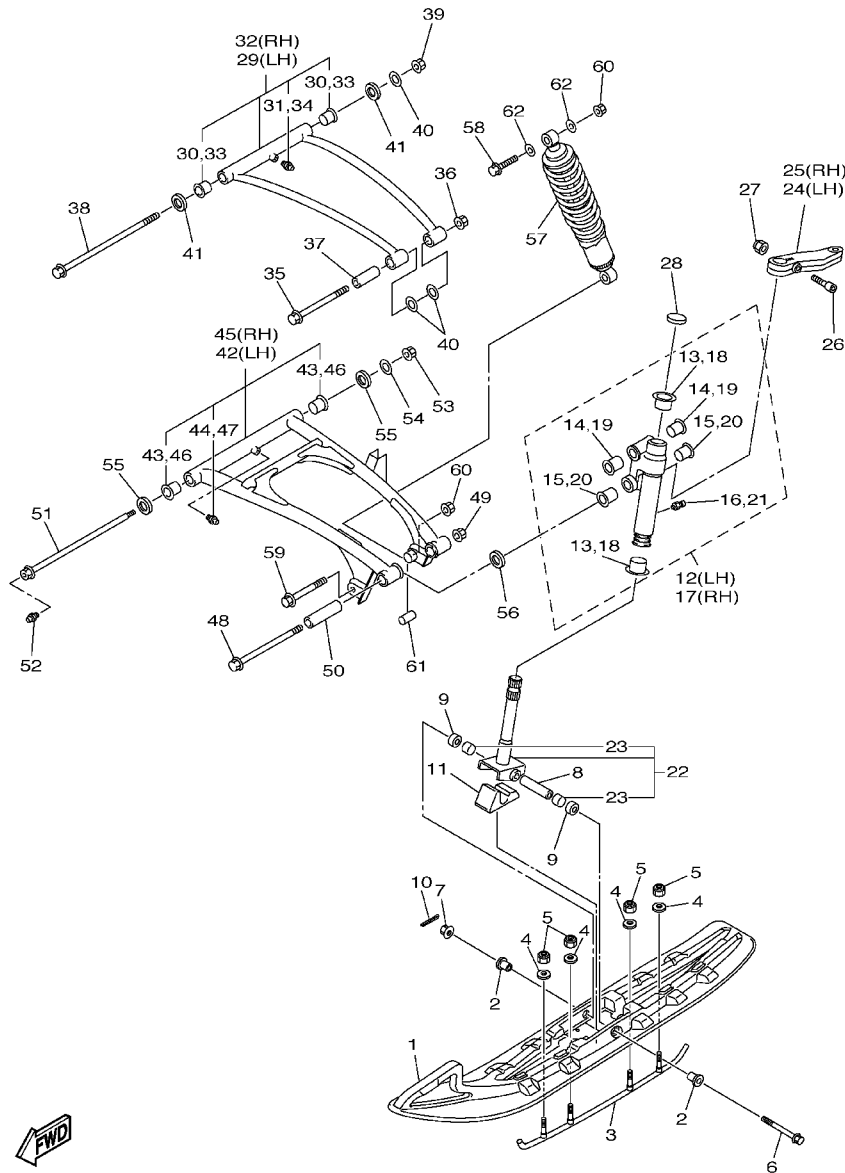

8JE2110-M201

FIG. 20 SKI

REF. NO.	PART NO.	DESCRIPTION	8JE2	8JE1	REMARKS
23	90384-16N51	.BUSH, BIMETAL FORMED	2	2	
24	8FN-23851-00	ARM, OUTSIDE 1	1	1	
25	8FN-23852-00	ARM, OUTSIDE 2	1	1	
26	90110-08104	BOLT, HEXAGON SOCKET HEAD	2	2	
27	95602-08200	NUT, SELF-LOCKING	2	2	
28	3YK-22472-40	CAP, CASE	2	2	
29	8GS-23540-20	FRONT UPPER ARM COMP. (LEFT)	1	1	
30	90381-15N50	.BUSH, SOLID	2	2	
31	93700-06004	.NIPPLE, GREASE	1	1	
32	8GS-23550-20	FRONT UPPER ARM COMP. (RIGHT)	1	1	
33	90381-15N50	.BUSH, SOLID	2	2	
34	93700-06004	.NIPPLE, GREASE	1	1	
35	90105-10230	BOLT, FLANGE	2	2	
36	95602-10200	NUT, U FLANGE	2	2	
37	90387-10099	COLLAR	2	2	
38	90109-10056	BOLT	2	2	
39	95602-10200	NUT, U FLANGE	2	2	
40	90201-10052	WASHER, PLATE	6	6	
41	90209-15N50	WASHER	4	4	
42	8GS-23570-20	FRONT LOWER ARM COMP. (LEFT)	1	1	
43	90381-16N51	.BUSH, SOLID	2	2	
44	93700-06004	.NIPPLE, GREASE	1	1	
45	8GS-23580-20	FRONT LOWER ARM COMP. (RIGHT)	1	1	
46	90381-16N51	.BUSH, SOLID	2	2	
47	93700-06004	.NIPPLE, GREASE	1	1	
48	90105-12078	BOLT, FLANGE	2	2	
49	95602-12200	NUT, SELF-LOCKING	2	2	

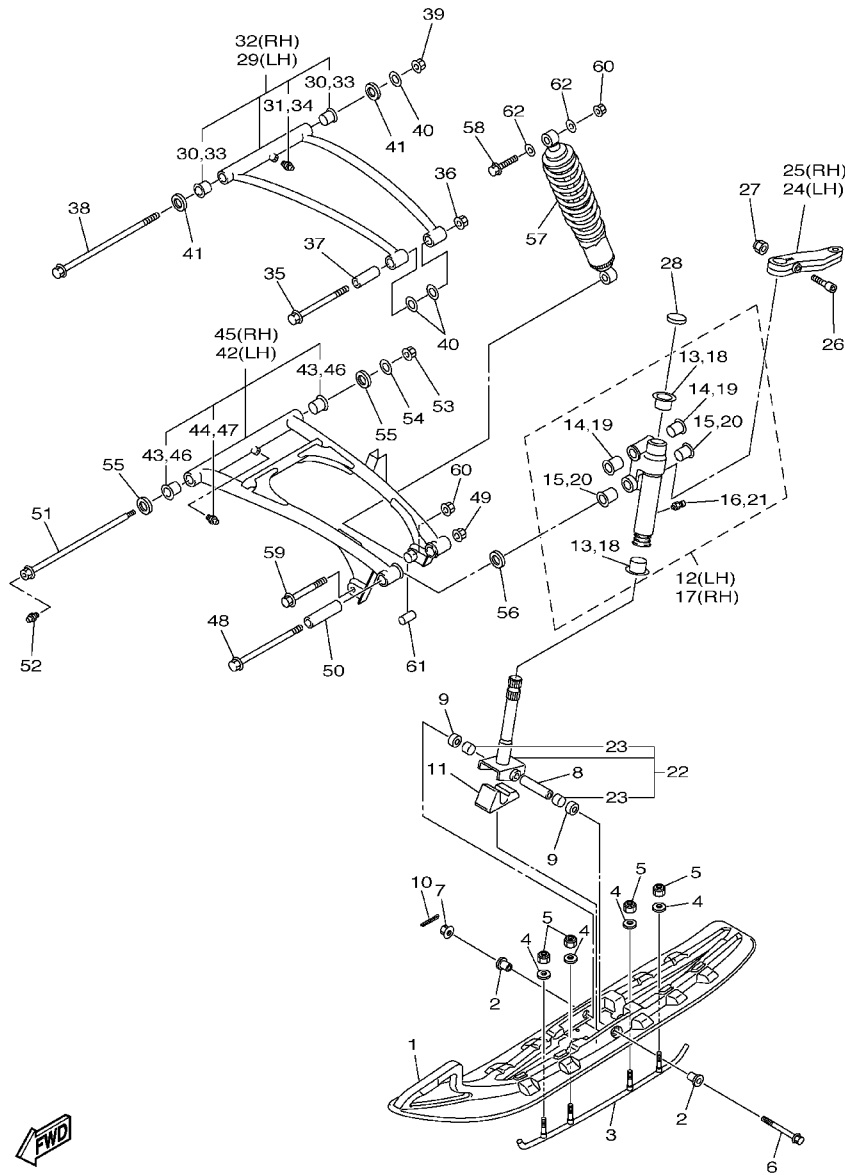

8JE2110-M201

FIG. 20 SKI

REF. NO.	PART NO.	DESCRIPTION	8JE2	8JE1	REMARKS
50	90387-12054	COLLAR	2	2	
51	90401-10045	BOLT, UNION	2	2	
52	93700-06004	NIPPLE, GREASE	2	2	
53	95602-10200	NUT, U FLANGE	2	2	
54	90201-10052	WASHER, PLATE	2	2	
55	90209-15N50	WASHER	4	4	
56	90201-12032	WASHER, PLATE	4	4	
57	8JE-2376A-00	ABSORBER ASSY 1	2	2	
58	90105-10232	BOLT, FLANGE	2	2	
59	90105-10392	BOLT, FLANGE	2	2	
60	95602-10200	NUT, U FLANGE	4	4	
61	90387-10N59	COLLAR	2	2	
62	90201-106F2	WASHER, PLATE	4	4	

FIG. 21 STEERING

REF. NO.	PART NO.	DESCRIPTION	8J/E2	8J/E1	REMARKS
1	8FN-26110-10	HANDLE COMP.	1	1	
2	8FS-23829-00	STRAP, STRG	1	1	
3	92014-06020	BOLT, BUTTON HEAD	2	2	
4	8FA-23813-01	COLUMN, STEERING 2	1	1	
5	8K1-23814-00	HOLDER, HANDLE	2	2	
6	8ED-23442-00	HOLDER, HANDLE LOWER	1	1	
7	8DF-23857-00	HOLDER	1	1	
8	8FK-2381B-00	JOINT	1	1	
9	90105-08072	BOLT, FLANGE	4	4	
10	90201-08020	WASHER, PLATE	2	2	
11	8FA-23811-00	COLUMN, STEERING	1	1	
12	8FA-23818-02	COVER, STEERING	1	1	
13	8FA-23873-01	BEARING, STEERING UPPER	1	1	
14	8FN-23867-00	HOLDER 2	1	1	
15	90105-10549	BOLT, FLANGE	1	1	
16	95602-10200	NUT, U FLANGE	1	1	
17	90105-08552	BOLT, FLANGE	2	2	
18	95602-08200	NUT, SELF-LOCKING	2	2	
19	90468-12006	CLIP	3	3	
20	8FA-23872-00	HOLDER, BEARING	1	1	
21	8FN-2376H-00	HOLDER, BEARING	1	1	
22	8FA-23812-00	BEARING, STEERING	6	6	
23	8FA-23867-00	HOLDER 2	2	2	
24	8FN-23872-00	HOLDER, BEARING	1	1	
25	95312-08600	NUT	6	6	
26	1UY-23894-01	WASHER, LOCK 1	3	3	
27	8HF-2412G-00	COLLAR	6	6	

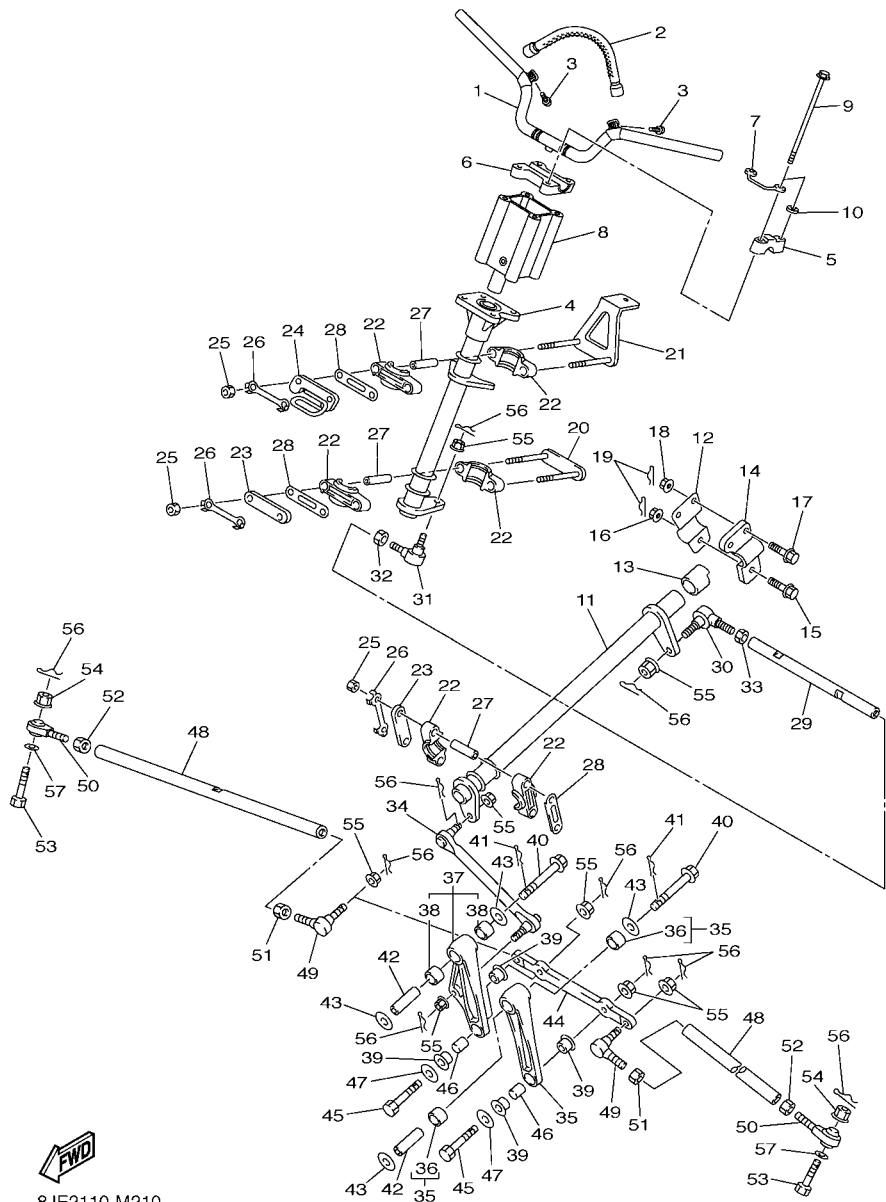

8JE2110-M210

FIG. 21 STEERING

REF. NO.	PART NO.	DESCRIPTION	Q/EZ	Q/EI	REMARKS
28	8FA-23843-00	WASHER, PLAIN	3	3	
29	8FN-23828-00	ROD, STEERING	1	1	
30	8CR-23847-00	JOINT, UNIVERSAL 3	1	1	
31	8CR-23845-10	JOINT, UNIVERSAL 2	1	1	
32	95307-10700	NUT	1	1	
33	90170-10186	NUT	1	1	(L.H. THREAD)
34	8FA-23821-00	ROD, STEERING RELAY	1	1	
35	8FN-2389K-00	ARM PIVOT ASSY	1	1	
36	90383-17001	.BUSH, FORMED	2	2	
37	8FN-2389M-00	PIVOT ARM ASSY 2	1	1	
38	93317-41785	.BEARING	2	2	
39	90381-14001	BUSH, SOLID	4	4	
40	90105-12017	BOLT, FLANGE	2	2	
41	8FA-2384N-00	CLIP, RING	2	2	
42	8FA-2412G-00	COLLAR	2	2	
43	90201-121U3	WASHER, PLATE	4	4	
44	8FN-23826-00	ARM, IDLER	1	1	
45	90102-10044	BOLT, WITH HOLE	2	2	
46	90387-10008	COLLAR	2	2	
47	90201-10742	WASHER, PLATE	2	2	
48	8FN-23831-00	ROD, TIE	2	2	
49	8CR-23845-10	JOINT, UNIVERSAL 2	2	2	
50	8FA-23847-00	JOINT, UNIVERSAL 3	2	2	
51	95307-10700	NUT	2	2	
52	90170-10186	NUT	2	2	(L.H. THREAD)
53	90102-10044	BOLT, WITH HOLE	2	2	
54	95702-10300	NUT, NYLON	2	2	

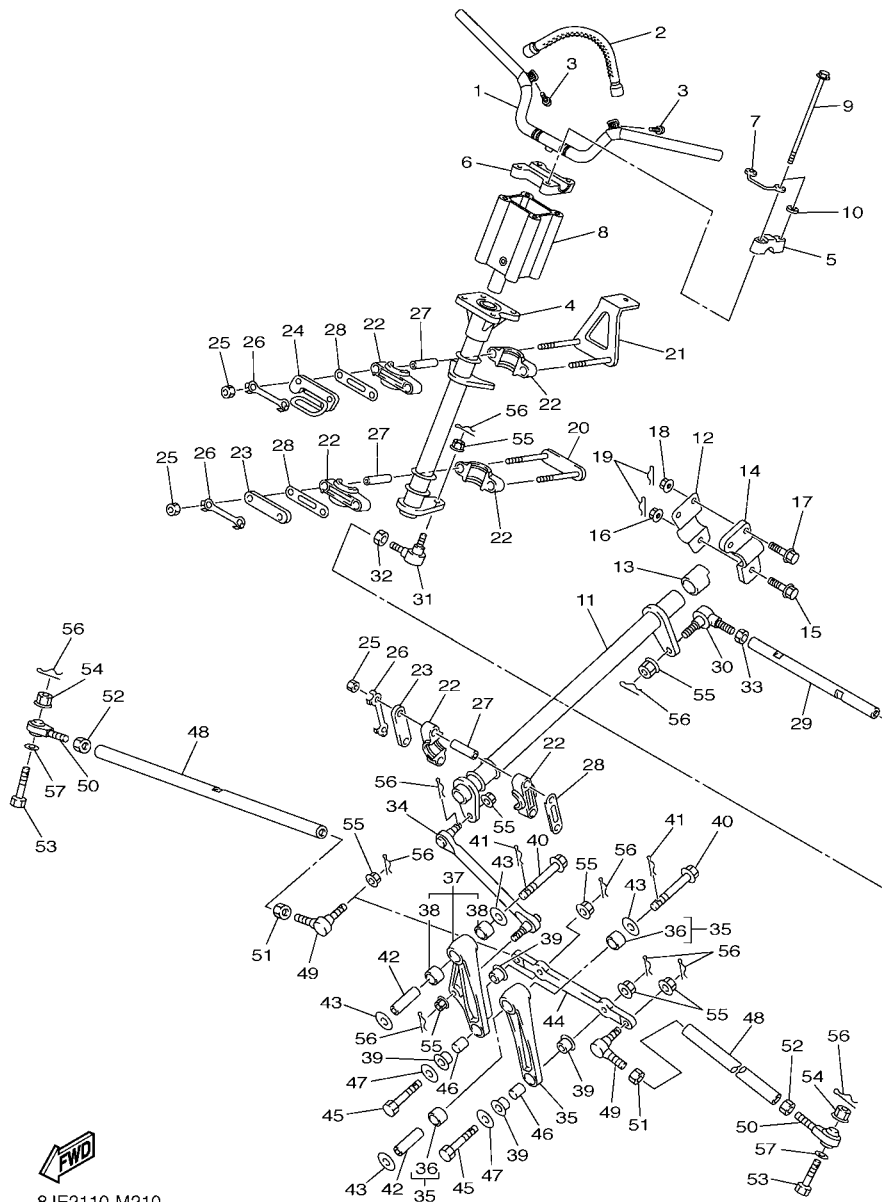

8JE2110-M210

FIG. 21 STEERING

REF. NO.	PART NO.	DESCRIPTION	8JE2	8JE1		REMARKS
55	95702-10500	NUT, FLANGE	8	8		
56	91402-20020	PIN, COTTER	10	10		
57	90201-08759	WASHER, PLATE	2	2		

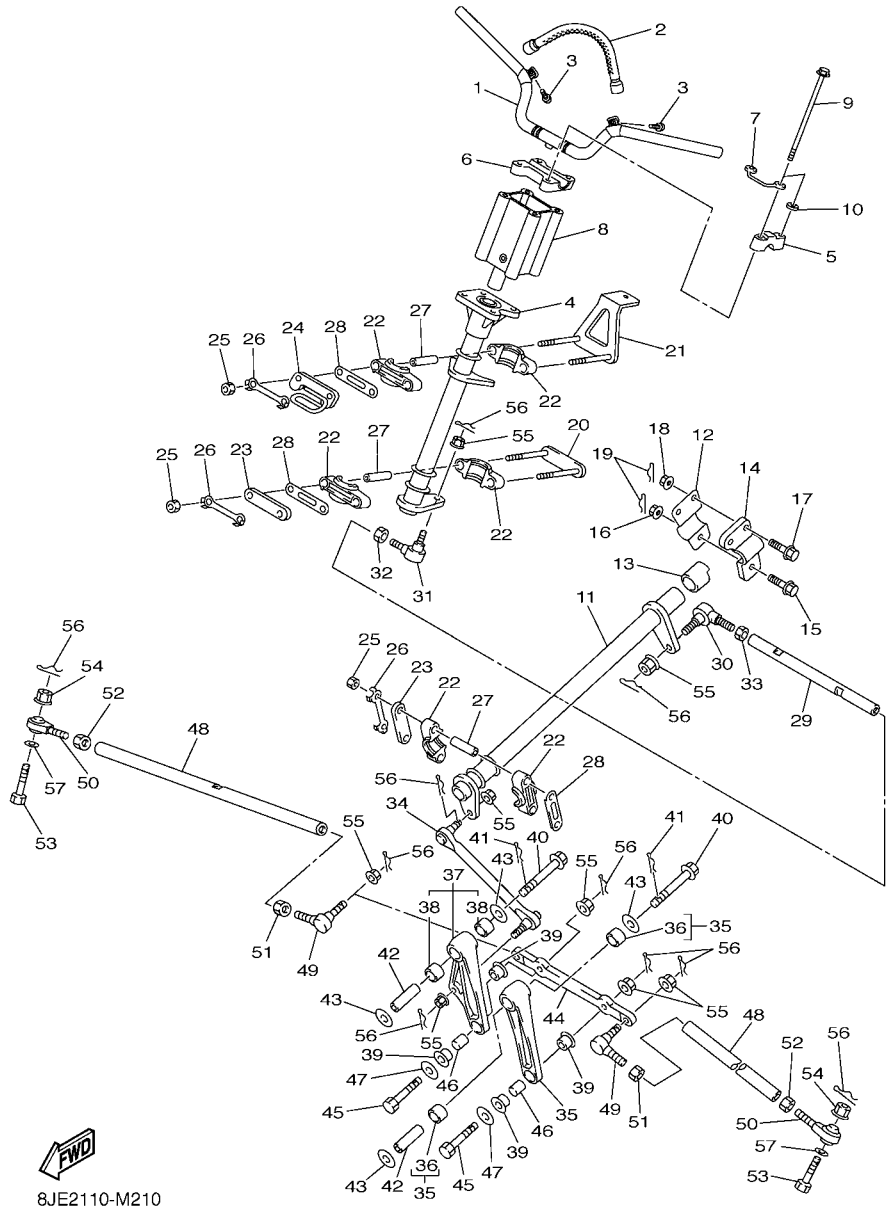

8JE2110-M210

FIG. 22 STEERING GATE

REF. NO.	PART NO.	DESCRIPTION	8JE2	8JE1	REMARKS
1	8GS-23870-01	STEERING GATE COMP.	1	1	
2	90464-11007	.CLAMP	2	2	
3	90464-14M55	.CLAMP	1	1	
4	8FN-24181-00	DAMPER, LOCATING 1	2	2	
5	8FN-24182-00	DAMPER, LOCATING 2	1	1	
6	8FA-2389C-E0	LABEL, CAUTION	1		
	8FA-2389C-S0	LABEL, CAUTION		1	UR FOR EUR,RUS
	8FA-2389C-J0	LABEL, CAUTION		1	UR FOR JPN
7	90105-081A7	BOLT, FLANGE	2	2	
8	90201-08326	WASHER, PLATE	4	4	
9	95822-08020	BOLT, FLANGE	7	7	
10	8FA-2389E-00	LATCH	1	1	
11	95602-08200	NUT, SELF-LOCKING	9	9	
12	90462-10022	CLAMP	2	2	
13	8FN-23815-00	PAD, STEERING	1	1	
14	8ES-14146-00	PLATE	1	1	AP
15	90150-06015	SCREW, ROUND HEAD	1	1	AP

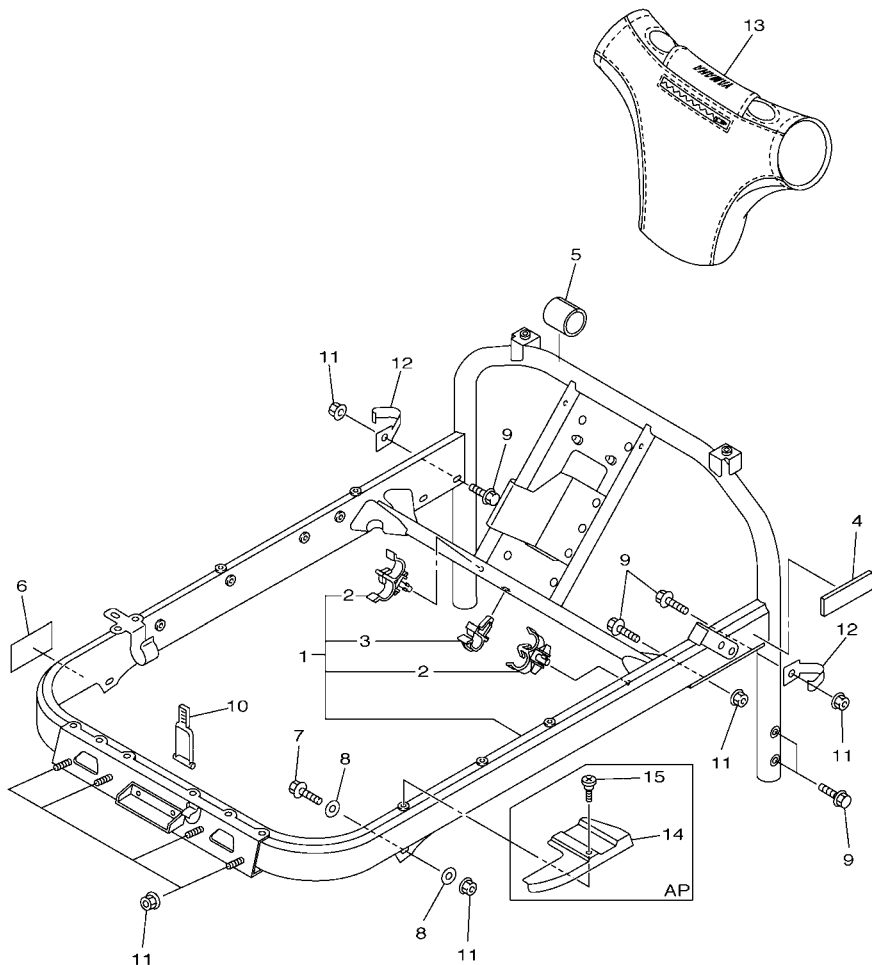

8JE2110-M220

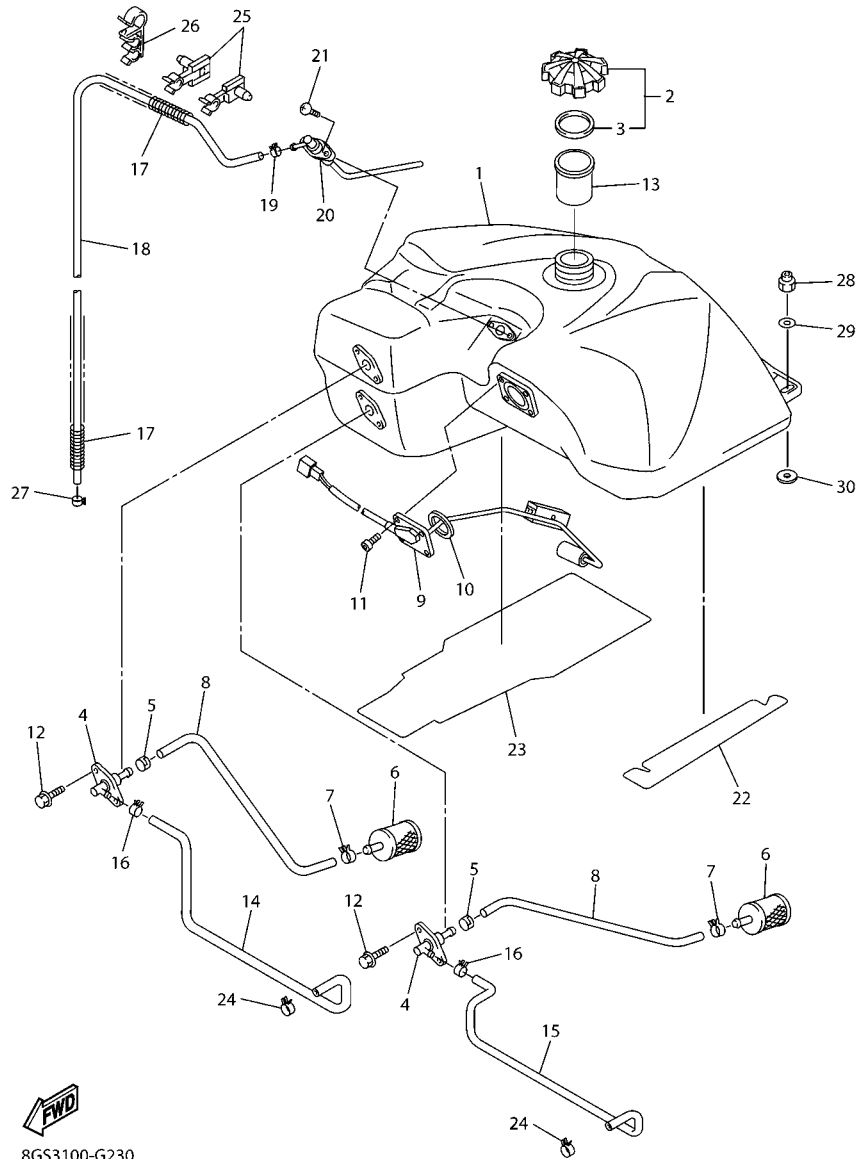

8GS3100-G230

FIG. 23 FUEL TANK

REF. NO.	PART NO.	DESCRIPTION	8/E2	8/E1		REMARKS
1	8FN-24111-10	TANK, FUEL	1			
	8FN-24111-01	TANK, FUEL		1		
2	8FG-24610-01	CAP ASSY	1	1		
3	8HV-24641-00	.GASKET, CAP 1	1	1		
4	8CR-24301-01	SUCTION PIPE COMP. 1	2	2		
5	90468-04092	CLIP	2	2		
6	8H5-24560-00	FILTER ASSY	2	2		
7	90467-11032	CLIP	2	2		
8	8FA-24335-00	PIPE, SUCTION 1	2	2		
9	8GS-85752-00	SENDER UNIT ASSY, FUEL METER	1	1		
10	93210-41041	O-RING	1	1		
11	98902-05008	SCREW, BIND	4	4		
12	90105-060A6	BOLT, FLANGE	4	4		
13	8FN-24114-00	TUBE, FILLER	1	1		
14	8GS-24311-00	PIPE, FUEL 1	1			
	8FN-24311-00	PIPE, FUEL 1		1		
15	8GS-24311-10	PIPE, FUEL 1	1			
	8FN-24311-10	PIPE, FUEL 1		1		
16	90467-11032	CLIP	2	2		
17	90501-08668	SPRING, COMPRESSION	2	2		
18	91A20-05130	TUBE, FLEXIBLE VINYL	1	1		
19	90467-09026	CLIP	1	1		
20	8FN-2418A-01	BREATHER COMP.	1	1		
21	90149-06330	SCREW	2	2		
22	8GS-24181-00	DAMPER, LOCATING 1	1			
23	8GS-24182-00	DAMPER, LOCATING 2	1			
24	90467-11032	CLIP	2	2		

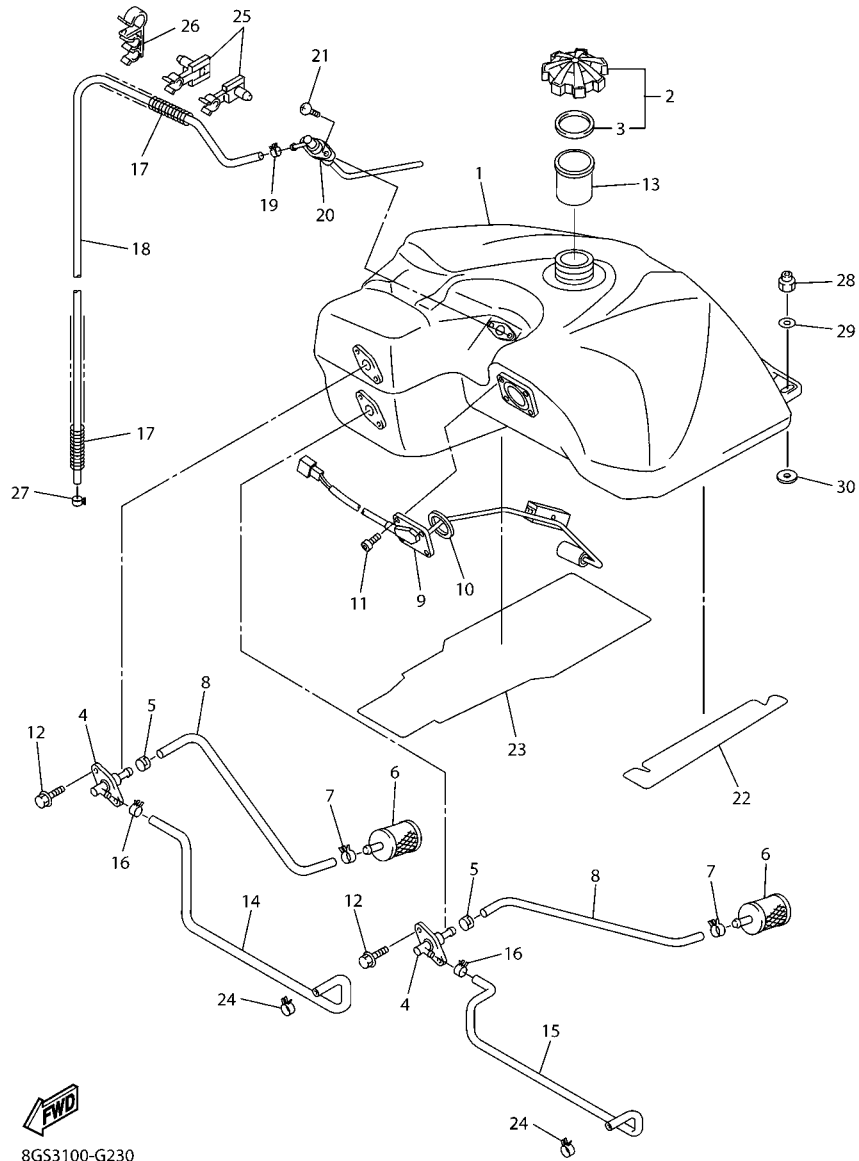

FWD
8GS3100-G230

FIG. 23 FUEL TANK

REF. NO.	PART NO.	DESCRIPTION	QTY	REMARKS
25	90464-09015	CLAMP	2	
26	90464-16010	CLAMP	1	
27	90467-09026	CLIP	1	
28	95702-08300	NUT, NYLON	2	
29	90201-08053	WASHER, PLATE	2	
30	90201-08075	WASHER, PLATE	2	

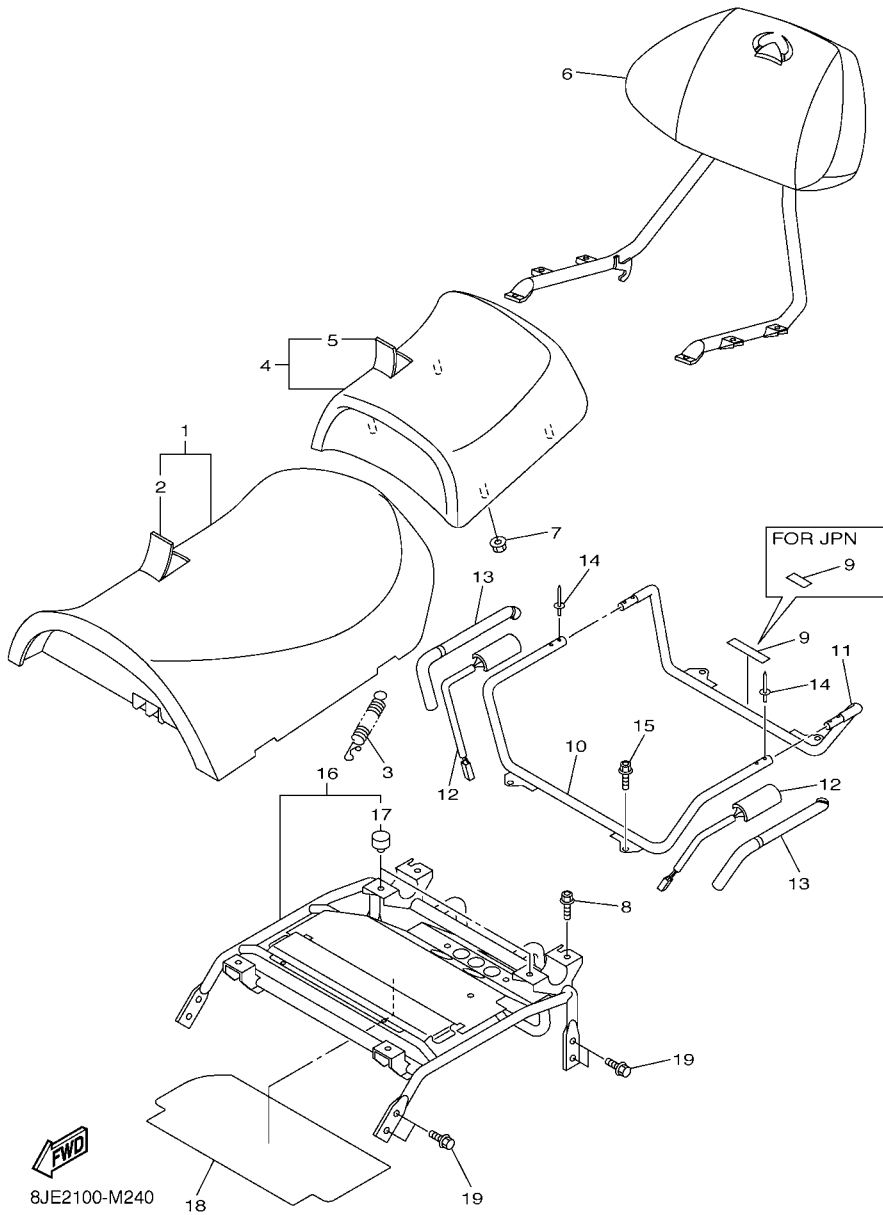
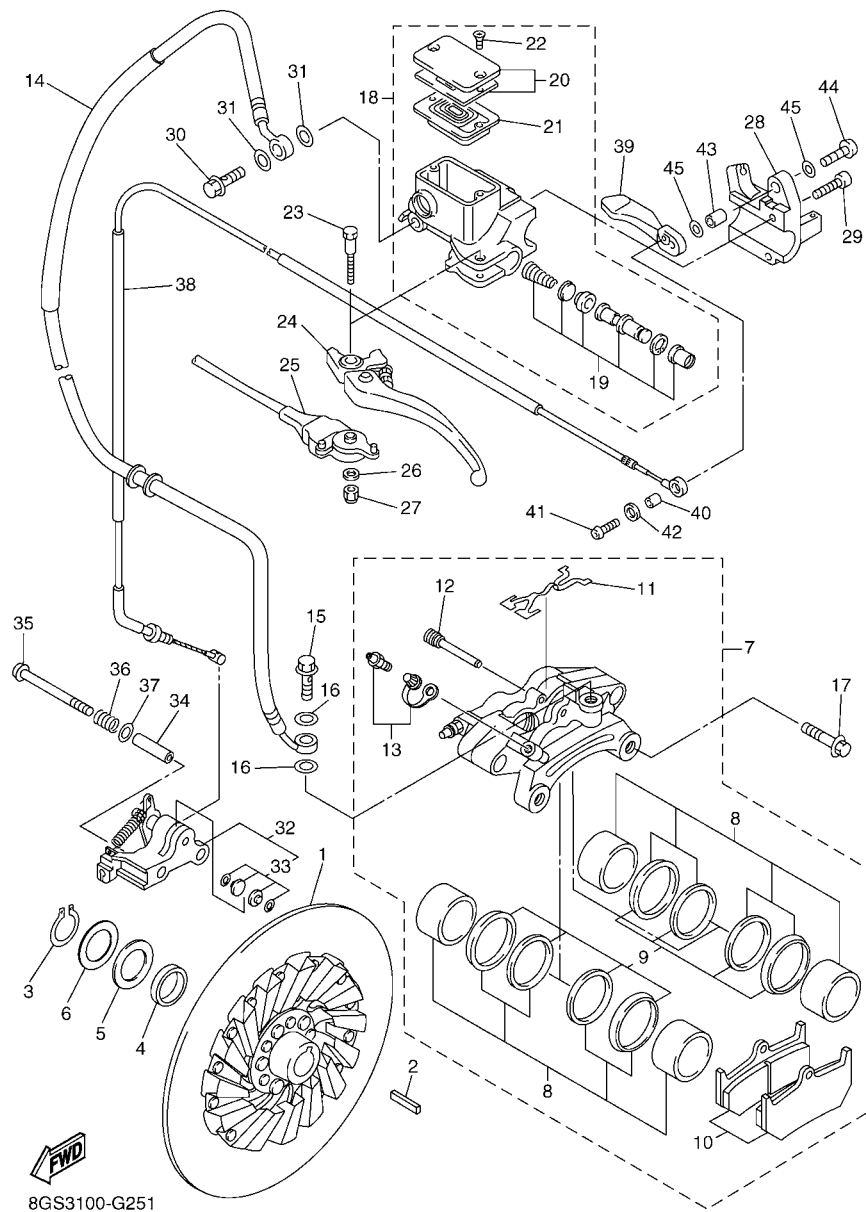

FIG. 24 SEAT

REF. NO.	PART NO.	DESCRIPTION	8JE2	8JE1	REMARKS
1	8FN-24710-10	SINGLE SEAT ASSY	1	1	
2	8FN-2470F-10	.SEAT COVER COMP.	1	1	
3	89A-77159-00	CLAMP, ROD	1	1	
4	8FN-24750-10	TANDEM SEAT ASSY	1	1	
5	8FN-2470H-10	.SEAT COVER COMP. ,2	1	1	
6	8FN-24790-10	SEAT BACK ASSY	1	1	
7	95702-06500	NUT, FLANGE	4	4	
8	90105-10151	BOLT, FLANGE	2	2	
9	8FN-24897-00	EMBLEM	1		UR FOR EUR,RUS
	8FN-24897-10	EMBLEM		1	UR FOR JPN
	3AC-24877-C0	LABEL, CAUTION		1	
10	8FN-2474A-00	ASSIST, GRIP	1	1	
11	8FN-2474W-00	ASSIST,GRIP 2	1	1	
12	8GS-2474B-00	ASSIST GRIP WARMER ASSY 1	2	2	
13	8GJ-2842M-00	COVER 1	2	2	
14	90267-47186	RIVET, BLIND (4.7X16.4 BLACK)	6	6	
15	90105-10151	BOLT, FLANGE	2	2	
16	8FN-2474H-00	BRACKET, ASSIST GRIP 1	1	1	
17	8FA-27114-00	.STOPPER	2	2	
18	8FN-2476U-00	PROTECTOR,1	1	1	
19	95822-08014	BOLT, FLANGE	8	8	



8GS3100-G251

FIG. 25 BRAKE

REF. NO.	PART NO.	DESCRIPTION	8/E2	8/E1	REMARKS
1	8FU-2581T-00	DISK BRAKE ASSY	1	1	
2	90282-07002	KEY, STRAIGHT	1	1	
3	99009-24400	CIRCLIP	1	1	
4	90387-25011	COLLAR	1	1	
5	90201-25527	WASHER, PLATE (T1.0)	2	2	UN
6	90201-252F1	WASHER, PLATE (T0.5)	2	2	UN
7	8FU-2580T-01	CALIPER ASSY (LEFT)	1	1	
8	8FU-W0057-00	.PISTON ASSY, CALIPER	2	2	
9	3JD-W0047-10	..CALIPER SEAL KIT	1	1	
10	8FU-W0046-01	.BRAKE PAD KIT 2	1	1	
11	8FU-25919-00	.SUPPORT, PAD	1	1	
12	8FU-25924-00	.PIN, PAD	1	1	
13	8CR-W0048-00	.BLEED SCREW KIT	2	2	
14	8GS-25872-01	HOSE, BRAKE 1	1	1	
15	90401-10015	BOLT, UNION	1	1	
16	90201-10118	WASHER, PLATE	2	2	
17	90105-10096	BOLT, FLANGE	2	2	
18	8EN-W2587-00	MASTER CYLINDER SUB ASSY	1	1	UR FOR EUR,RUS
	8EN-W2587-10	MASTER CYLINDER SUB ASSY		1	UR FOR JPN
19	8CR-W0041-00	.CYLINDER KIT, MASTER	1	1	
20	8CR-W2585-00	.RESERVOIR CAP SET	1	1	UR FOR EUR,RUS
	3GM-W2585-21	.RESERVOIR CAP SET		1	UR FOR JPN
21	55U-25854-00	.DIAPHRAGM, RESERVOIR	1	1	
22	98706-04012	.SCREW, FLAT HEAD	2	2	
23	8CR-2589F-00	BOLT, LEVER	1	1	
24	8CR-83912-00	LEVER 1	1	1	STD
	8DN-83912-00	LEVER 1		1	AP

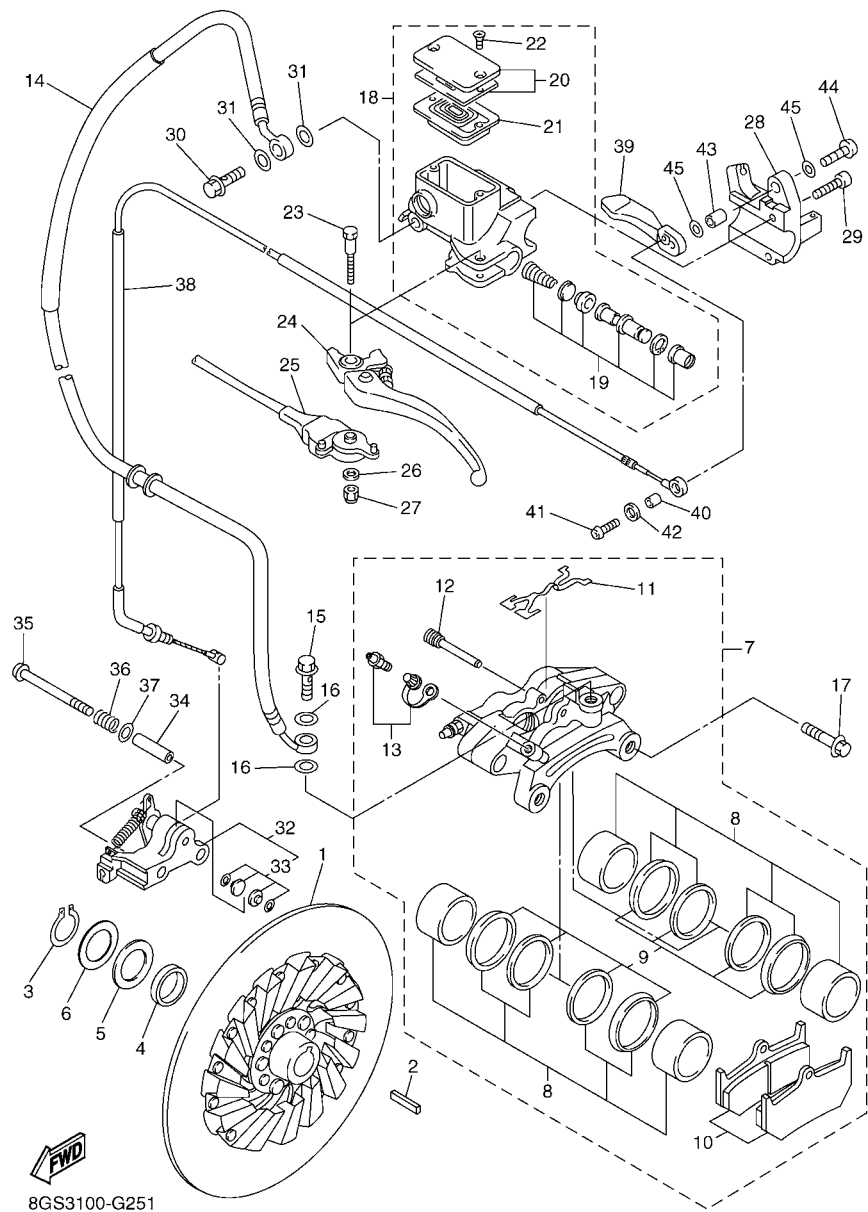

8GS3100-G251

FIG. 25 BRAKE

REF. NO.	PART NO.	DESCRIPTION	QTY	QTY	REMARKS
25	8CR-82530-01	STOP SWITCH ASSY	1	1	
26	8CR-8398X-00	WASHER, PLATE	1	1	
27	95707-05300	NUT, FLANGE	1	1	
28	8FA-25867-00	BRACKET, MASTER CYLINDER	1	1	
29	91316-06022	BOLT	2	2	
30	90401-10015	BOLT, UNION	1	1	
31	90201-10118	WASHER, PLATE	2	2	
32	8FU-25970-01	PARKING BRAKE COMP.	1	1	
33	8FA-W0045-00	.PARKING BRAKE PAD KIT	1	1	
34	90387-06058	COLLAR	2	2	
35	90111-06042	BOLT,HEX. SOCKET BUTTON	2	2	
36	90501-120A0	SPRING, COMPRESSION	2	2	
37	90201-12161	WASHER, PLATE	2	2	
38	8FN-26351-10	CABLE, BRAKE	1	1	
39	8FA-83922-00	LEVER 2	1	1	
40	90387-06043	COLLAR	1	1	
41	92017-06014	BOLT, BUTTON HEAD	1	1	
42	90201-06050	WASHER, PLATE	1	1	
43	90387-081M9	COLLAR	1	1	
44	90111-08054	BOLT,HEX. SOCKET BUTTON	1	1	
45	90201-08403	WASHER, PLATE	2	2	

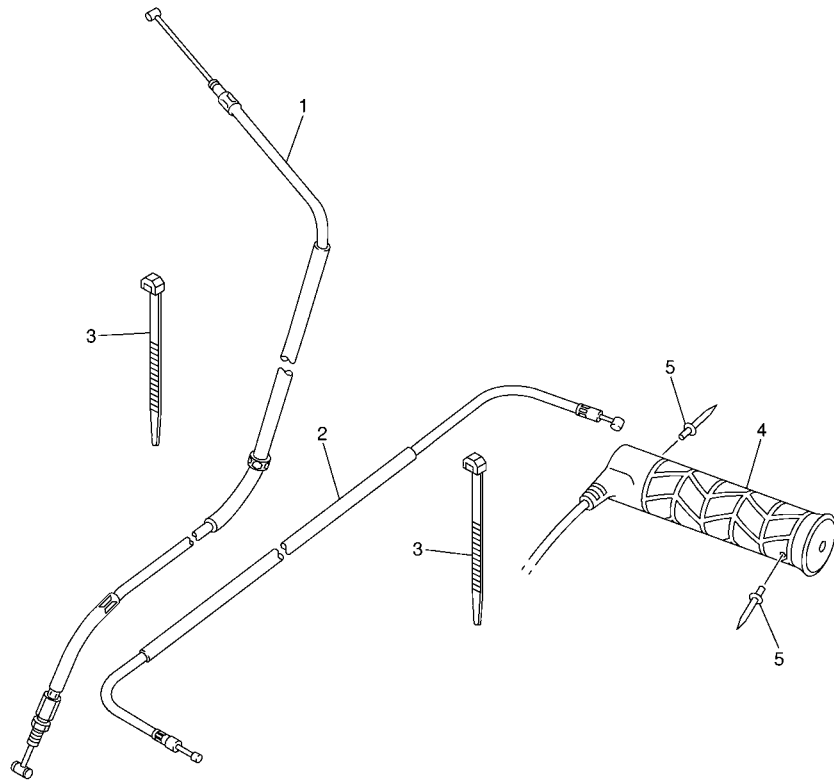

FIG. 26 CONTROL CABLE

REF. NO.	PART NO.	DESCRIPTION	8/E2	8/E1		REMARKS
1	8FN-26311-00	CABLE, THROTTLE 1	1	1		
2	8FN-26330-00	STARTER CABLE ASSY	1	1		
3	90464-13073	CLAMP	2	2		
4	8DM-26240-02	GRIP ASSY	2	2		
5	90267-48014	RIVET, BLIND (4.8X15.1 BLACK)	4	4		



8FN1100-E260

FIG. 27 TRACK SUSPENSION 1

REF. NO.	PART NO.	DESCRIPTION	Q/EZ	Q/EI	REMARKS
1	8JE-4741A-00	FRAME, SLIDING	2	2	
2	8JE-47421-00	RUNNER, SLIDING 1	2	2	
3	90151-06010	SCREW, COUNTERSUNK	2	2	
4	8GL-47422-00	RUNNER, SLIDING 2	2	2	
5	90267-48194	RIVET, BLIND (4.8X28 SILVER)	4	4	
6	90201-047R8	WASHER, PLATE	4	4	
7	8ES-47456-00	DAMPER 1	2	2	
8	8K2-47458-01	PLATE, DAMPER	4	4	
9	90267-48199	RIVET, BLIND (4.8X28.3)	4	4	
10	8AC-47457-00	DAMPER 2	2	2	
11	8AC-47341-00	SPACER	2	2	
12	8AX-47458-00	PLATE, DAMPER	4	4	
13	90267-48199	RIVET, BLIND (4.8X28.3)	4	4	
14	8JD-47110-01	TRACK ASSY	1	1	
15	8HR-47113-09	.PLATE, REINFORCEMENT	72	72	
16	8HR-47115-09	.METAL, SLIDE	36	36	
17	8ES-47319-01	COLLAR	2	2	
18	8HF-47310-10	SUSPENSION WHEEL ASSY	2	2	
19	93306-00507	.BEARING	1	1	
20	90113-06039	BOLT, SET	2	2	
21	8AC-47550-00	GUIDE WHEEL ASSY	2	2	
22	8JD-47365-00	COLLAR 1	2	2	
23	90113-06039	BOLT, SET	2	2	
24	90109-10030	BOLT	2	2	
25	8GC-47496-00	STOPPER 2	2	2	
26	8GN-47338-00	COLLAR	2	2	
27	95812-10050	BOLT, FLANGE	2	2	

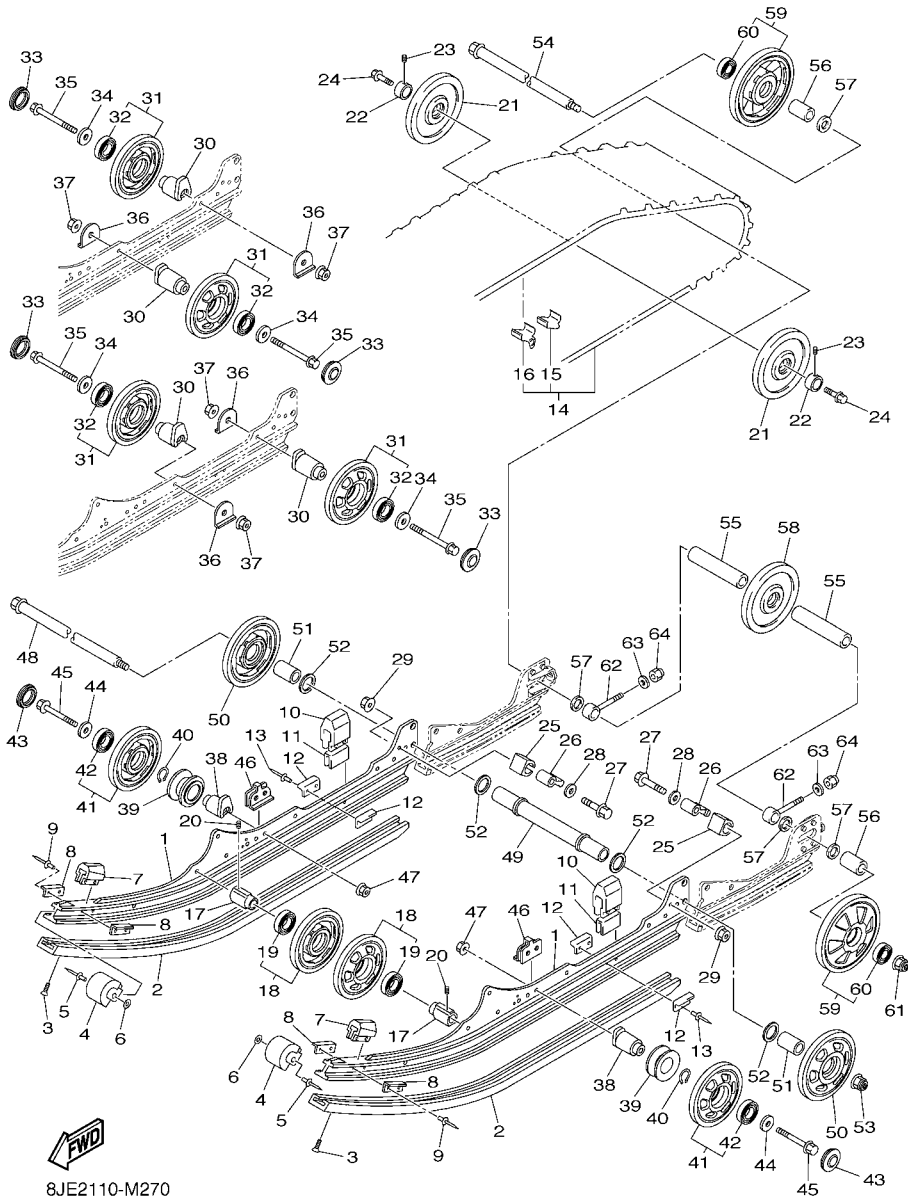

8JE2110-M270

FIG. 27 TRACK SUSPENSION 1

REF. NO.	PART NO.	DESCRIPTION	Q/EZ	Q/EI	REMARKS
28	90201-10061	WASHER, PLATE	2	2	
29	95602-10200	NUT, U FLANGE	2	2	
30	8ES-47419-00	BRACKET 7	4	4	
31	8HF-47310-10	SUSPENSION WHEEL ASSY	4	4	
32	93306-00507	.BEARING	1	1	
33	8HF-47317-00	CAP, WHEEL	4	4	
34	90201-10038	WASHER, PLATE	4	4	
35	95812-10080	BOLT, FLANGE	4	4	
36	90214-10003	WASHER, CLAW	4	4	
37	95602-10200	NUT, U FLANGE	4	4	
38	8ES-47419-10	BRACKET 7	2	2	
39	8ET-47446-00	HOOK 1	2	2	
40	99009-35400	CIRCLIP	2	2	
41	8HF-47310-10	SUSPENSION WHEEL ASSY	2	2	
42	93306-00507	.BEARING	1	1	
43	8HF-47317-00	CAP, WHEEL	2	2	
44	90201-10038	WASHER, PLATE	2	2	
45	95812-10080	BOLT, FLANGE	2	2	
46	8HP-47384-00	WASHER	2	2	
47	95602-10200	NUT, U FLANGE	2	2	
48	83R-47520-10	REAR AXLE COMP.	1	1	
49	83R-47469-10	COLLAR 1	1	1	
50	8HP-47310-10	SUSPENSION WHEEL ASSY	2	2	
51	90387-20022	COLLAR	2	2	
52	90201-20022	WASHER, PLATE	4	4	
53	95602-14200	NUT, SELF-LOCKING	1	1	
54	83R-47520-10	REAR AXLE COMP.	1	1	

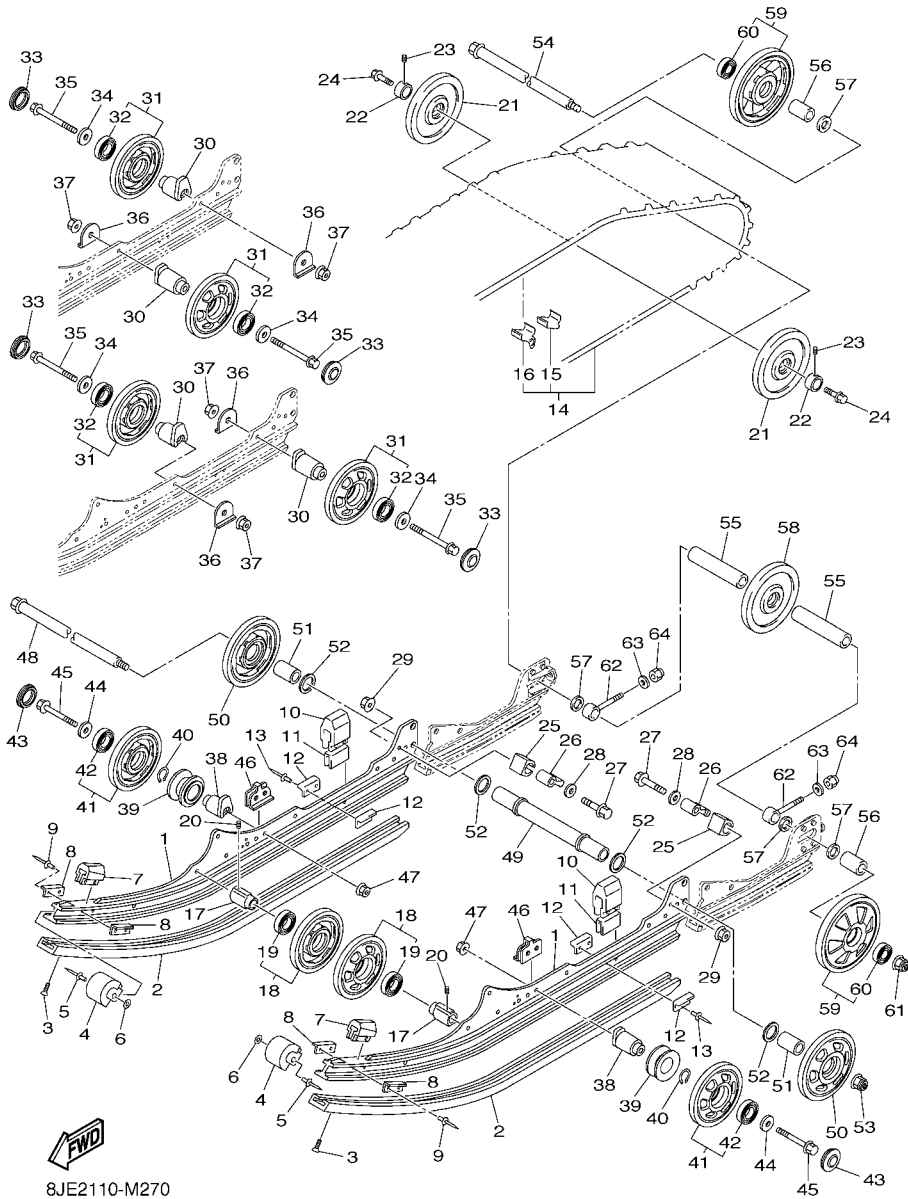

8JE2110-M270

FIG. 27 TRACK SUSPENSION 1

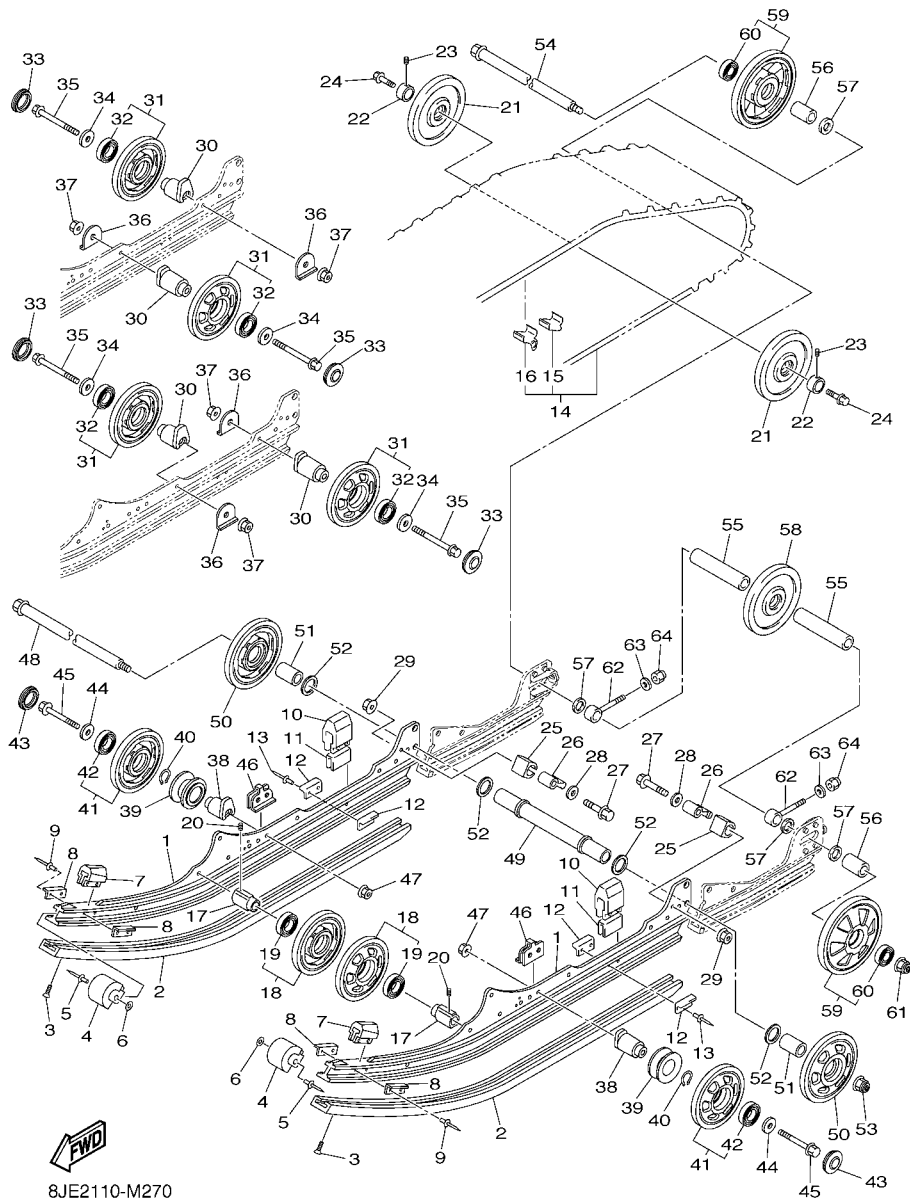

8JE2110-M270

REF. NO.	PART NO.	DESCRIPTION	QTY	QTY			REMARKS
55	90387-20023	COLLAR	2	2			
56	90387-20022	COLLAR	2	2			
57	90201-20022	WASHER, PLATE	4	4			
58	8CR-47550-10	GUIDE WHEEL ASSY	1	1			
59	8HF-47550-10	GUIDE WHEEL ASSY	2	2			
60	93306-00444	.BEARING	1	1			
61	95602-14200	NUT, SELF-LOCKING	1	1			
62	8DM-47479-00	COLLAR 3	2	2			
63	92902-10600	WASHER, PLATE	2	2			
64	95702-10300	NUT, NYLON	2	2			

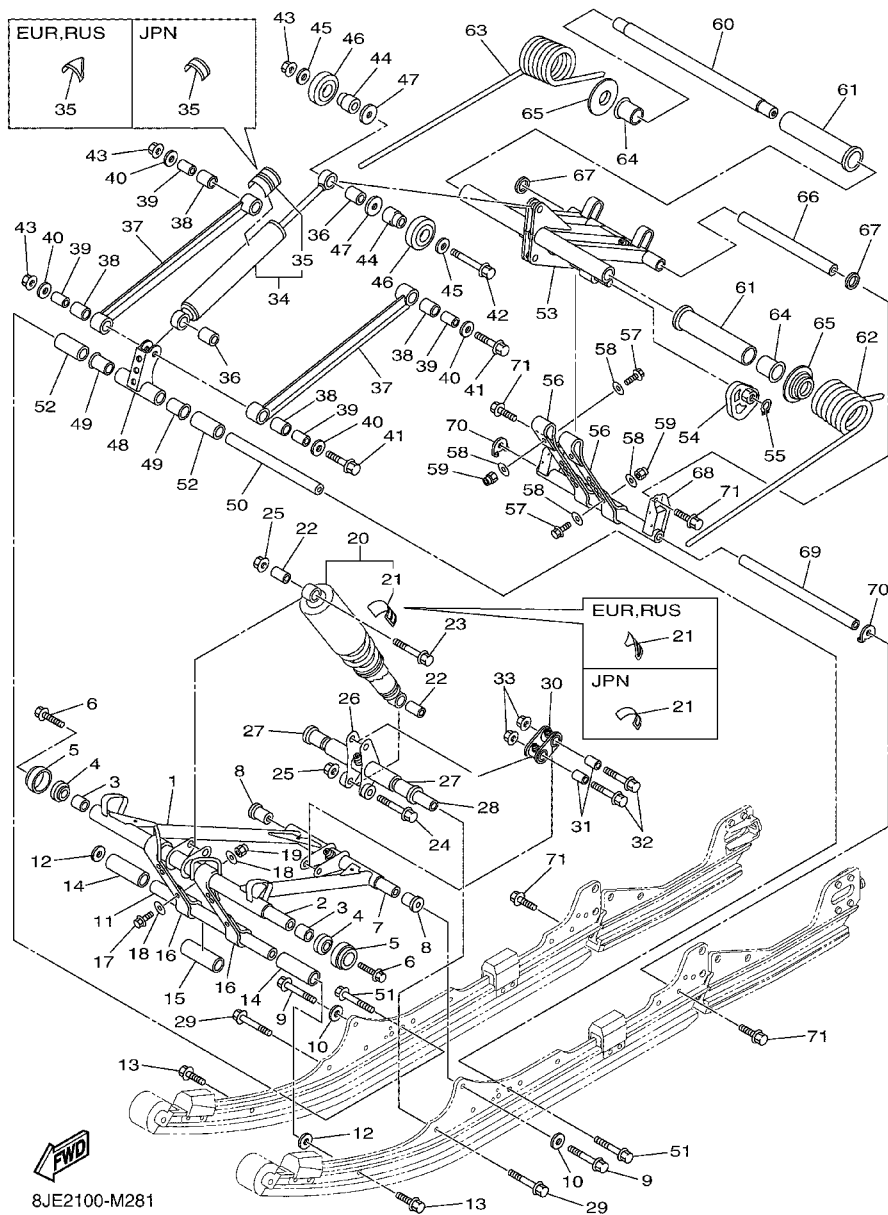

8JE2100-M281

FIG. 28 TRACK SUSPENSION 2

REF. NO.	PART NO.	DESCRIPTION	8JE2	8JE1	REMARKS
1	8JD-47331-00	ARM, PIVOT 1	1	1	
2	8JD-47465-00	SHAFT 1	1	1	
3	90383-23002	BUSH, FORMED	2	2	
4	93108-37011	OIL SEAL	2	2	
5	8HF-47341-00	SPACER	2	2	
6	90109-10030	BOLT	2	2	
7	8JD-47486-00	SHAFT 4	1	1	
8	90387-10022	COLLAR	2	2	
9	90105-10329	BOLT, FLANGE	2	2	
10	90201-10072	WASHER, PLATE	2	2	
11	83R-47485-02	SHAFT 3	1	1	
12	90201-10126	WASHER, PLATE	2	2	
13	90105-10237	BOLT, FLANGE	2	2	
14	90387-19002	COLLAR	2	2	
15	90445-26005	HOSE	1	1	
16	8JD-47495-00	STOPPER 1	2	2	
17	97002-06025	BOLT	4	4	
18	90201-06081	WASHER, PLATE	8	8	
19	95702-06300	NUT, NYLON	4	4	
20	8JE-47481-00	SHOCK ABSORBER 2	1		
	8JE-47481-10	SHOCK ABSORBER 2	1		UR FOR EUR,RUS
	8JE-47481-20	SHOCK ABSORBER 2	1		UR FOR JPN
21	4AA-22259-60	.LABEL, WARNING	1		
	4AA-22259-40	.LABEL, WARNING	1		UR FOR EUR,RUS
	4AA-22259-50	.LABEL, WARNING	1		UR FOR JPN
22	90387-10103	COLLAR	2	2	
23	95812-10045	BOLT, FLANGE	1	1	

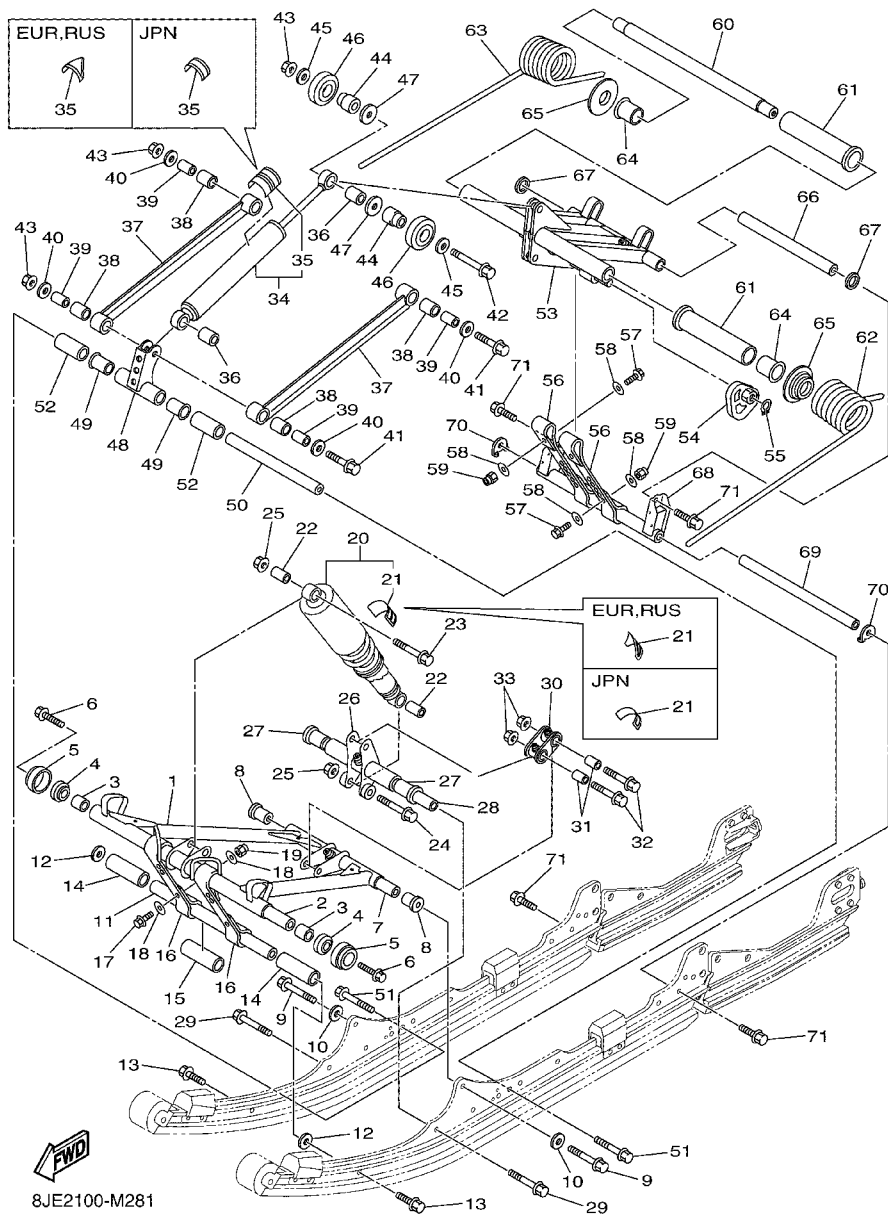

8JE2100-M281

FIG. 28 TRACK SUSPENSION 2

REF. NO.	PART NO.	DESCRIPTION	8JE2	8JE1	REMARKS
24	95812-10070	BOLT, FLANGE	1	1	
25	95602-10200	NUT, U FLANGE	2	2	
26	8JD-47349-00	BRACKET, ARM PIVOT	1	1	
27	90386-20001	BUSH	2	2	
28	8JD-47487-00	SHAFT 5	1	1	
29	90105-10209	BOLT, FLANGE	2	2	
30	8FK-47416-01	BRACKET 2	1	1	
31	90387-10024	COLLAR	2	2	
32	95812-10050	BOLT, FLANGE	2	2	
33	95602-10200	NUT, U FLANGE	2	2	
34	8JE-47480-00	SHOCK ABSORBER	1		
35	8JE-47480-10	SHOCK ABSORBER	1		UR FOR EUR,RUS
	8JE-47480-20	SHOCK ABSORBER	1		UR FOR JPN
	4AA-22259-60	.LABEL, WARNING	1		
36	4AA-22259-40	.LABEL, WARNING	1		UR FOR EUR,RUS
	4AA-22259-50	.LABEL, WARNING	1		UR FOR JPN
	90387-10023	COLLAR	2	2	
37	8HF-47494-00	ROD, RELAY	2	2	
38	90386-16001	BUSH	4	4	
39	90387-101A1	COLLAR	4	4	
40	90201-10043	WASHER, PLATE	4	4	
41	95812-10090	BOLT, FLANGE	2	2	
42	90105-10027	BOLT, FLANGE	1	1	
43	95602-10200	NUT, U FLANGE	3	3	
44	8AC-47366-00	COLLAR 2	2	2	
45	90201-10136	WASHER, PLATE	2	2	
46	8AC-47310-10	SUSPENSION WHEEL ASSY	2	2	

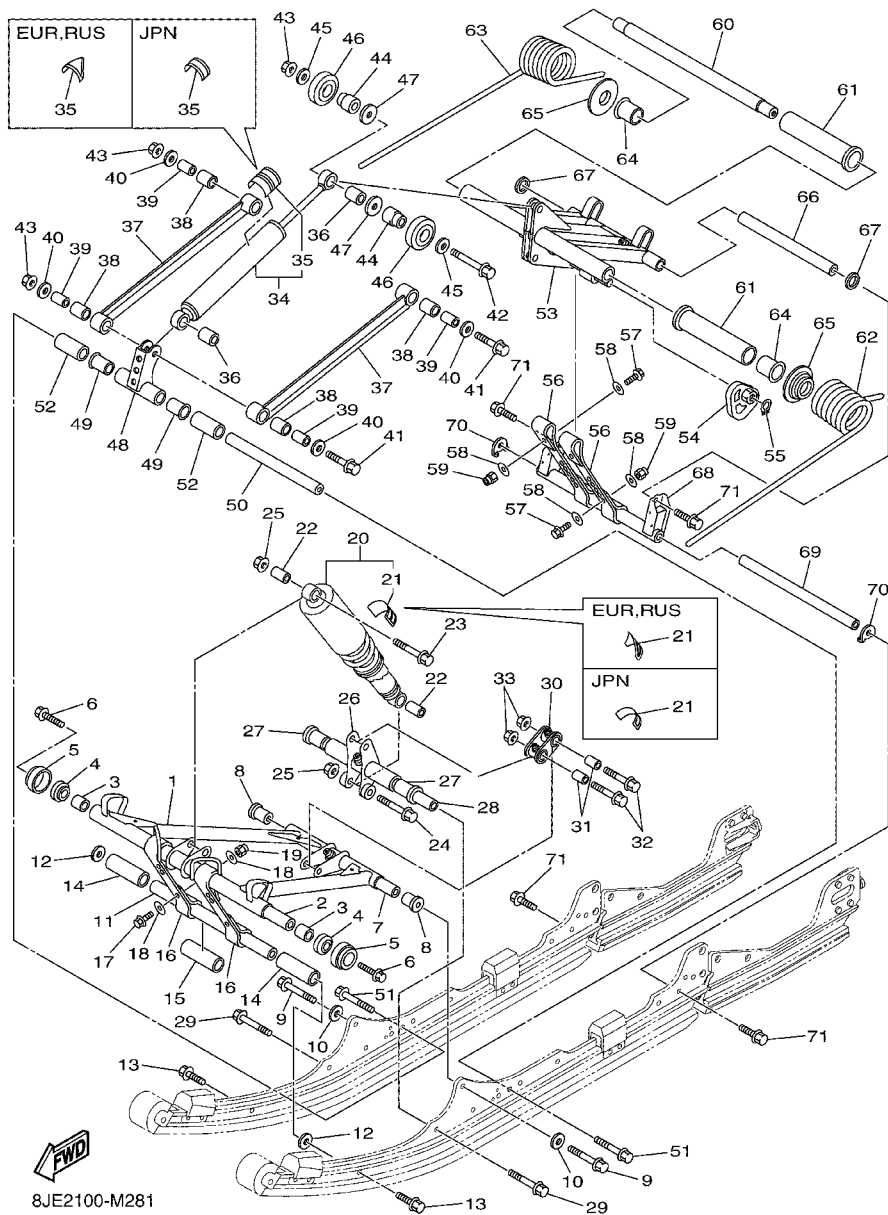
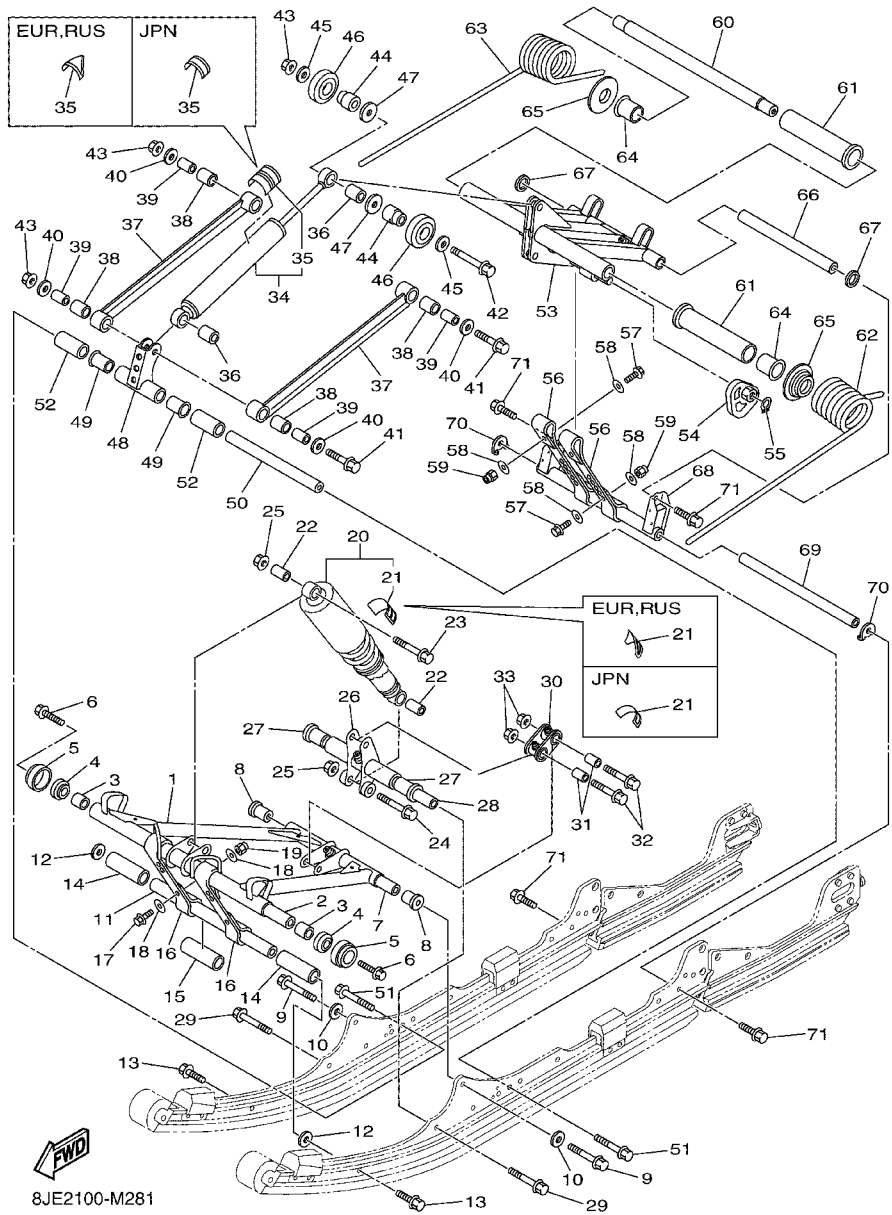

FIG. 28 TRACK SUSPENSION 2

REF. NO.	PART NO.	DESCRIPTION	8JE2	8JET	REMARKS
47	90201-103U7	WASHER, PLATE	2	2	
48	8JD-47349-10	BRACKET, ARM PIVOT	1	1	
49	90386-20001	BUSH	2	2	
50	8JD-47487-10	SHAFT 5	1	1	
51	90105-10209	BOLT, FLANGE	2	2	
52	8HP-47319-00	COLLAR	2	2	
53	8JD-47332-00	ARM, PIVOT 2	1	1	
54	8ES-47447-00	HOOK 2	2	2	
55	99009-14400	CIRCLIP	2	2	
56	8JD-47496-00	STOPPER 2	2	2	
57	97002-06025	BOLT	4	4	
58	90201-06081	WASHER, PLATE	8	8	
59	95702-06300	NUT, NYLON	4	4	
60	8JD-47475-00	SHAFT 2	1	1	
61	8GL-47445-00	PROTECTOR	2	2	
62	8JE-47473-10	SPRING, REAR 1(K=3400NMM/DEG)	1	1	UR FOR EUR,JPN
63	8JE-47473-00	SPRING, REAR 1(K=3600NMM/DEG)	1	1	UR FOR RUS
64	8JE-47474-10	SPRING, REAR 1(K=3400NMM/DEG)	1	1	UR FOR EUR,JPN
65	90381-28108	BUSH, SOLID	2	2	UR FOR RUS
66	8ES-47467-00	PLATE, GUIDE	2	2	
67	8JE-47488-00	SHAFT 6	1	1	
68	90201-19008	WASHER, PLATE	2	2	
69	8JD-47417-00	BRACKET 3	1	1	
70	83R-47485-02	SHAFT 3	1	1	
71	90214-10007	WASHER, CLAW	2	2	

FIG. 28 TRACK SUSPENSION 2



8JE2100-M281

REF. NO.	PART NO.	DESCRIPTION	8JE2	8JE1	REMARKS
71	90105-10237	BOLT, FLANGE	4	4	

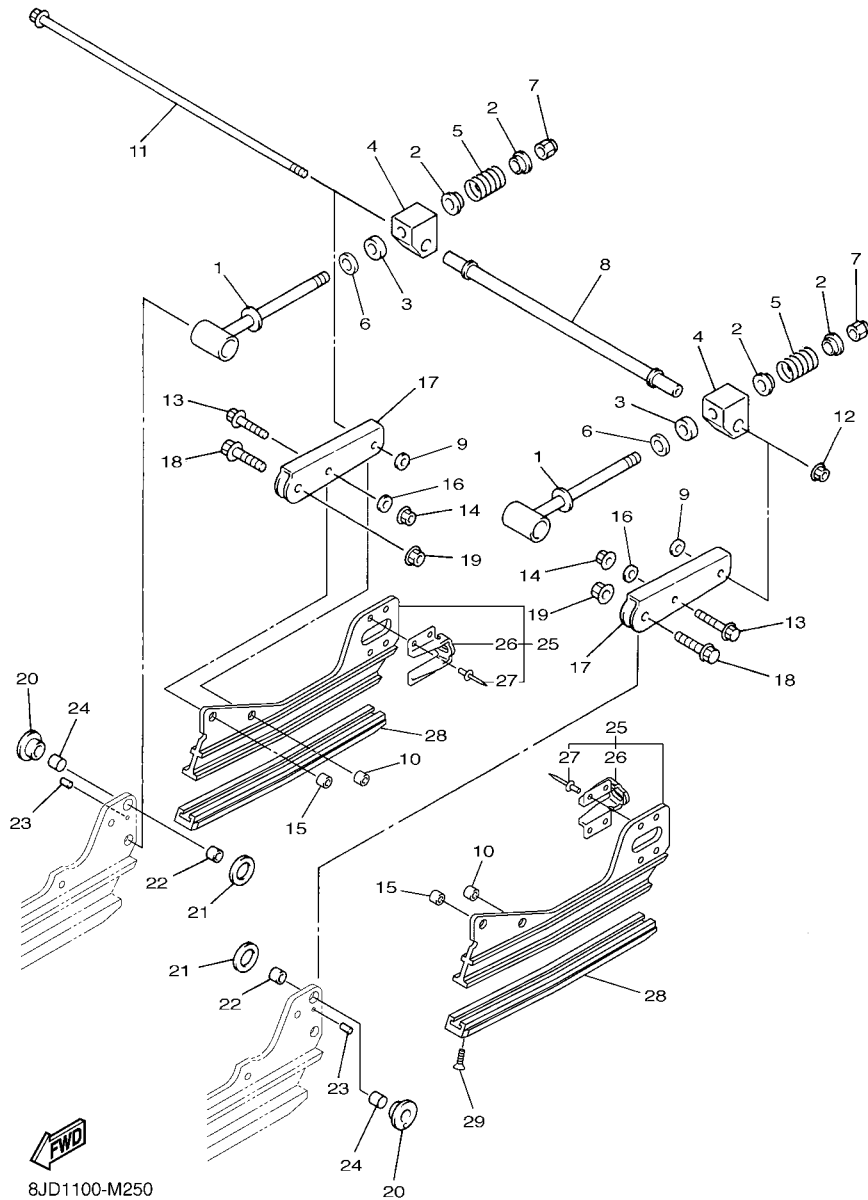

8JD1100-M250

FIG. 29 TRACK SUSPENSION 3

REF. NO.	PART NO.	DESCRIPTION	QTY	QTY	REMARKS
1	83R-47337-10	SHAFT, PIVOT	2	2	
2	83R-23768-00	SEAT, SPRING 1	4	4	
3	83R-47335-00	SPRING	2	2	
4	83R-47446-00	HOOK 1	2	2	
5	90501-407E4	SPRING, COMPRESSION	2	2	
6	90201-12317	WASHER, PLATE	2	2	
7	90185-12058	NUT, SELF-LOCKING	2	2	
8	8AC-47478-10	COLLAR 2	1	1	
9	90201-08649	WASHER, PLATE	2	2	
10	90387-082J1	COLLAR	2	2	
11	90105-08483	BOLT, FLANGE	1	1	
12	95602-08200	NUT, SELF-LOCKING	1	1	
13	95812-08035	BOLT, FLANGE	2	2	
14	95602-08200	NUT, SELF-LOCKING	2	2	
15	90387-082J1	COLLAR	2	2	
16	90201-08649	WASHER, PLATE	2	2	
17	8FM-47333-10	ARM, PIVOT 3	2	2	
18	95812-10030	BOLT, FLANGE	2	2	
19	90185-10019	NUT, SELF-LOCKING	2	2	
20	90387-1815A	COLLAR	2	2	
21	90202-22238	WASHER, PLATE	2	2	
22	90387-1014Y	COLLAR	2	2	
23	91609-30008	PIN, SPRING	2	2	
24	90380-16109	BUSH, SOLID	2	2	
25	8FM-W4741-10	FRAME, SLIDING	2	2	
26	8DM-4741B-00	.BRACKET	1	1	
27	8V0-47468-00	.RIVET	4	4	

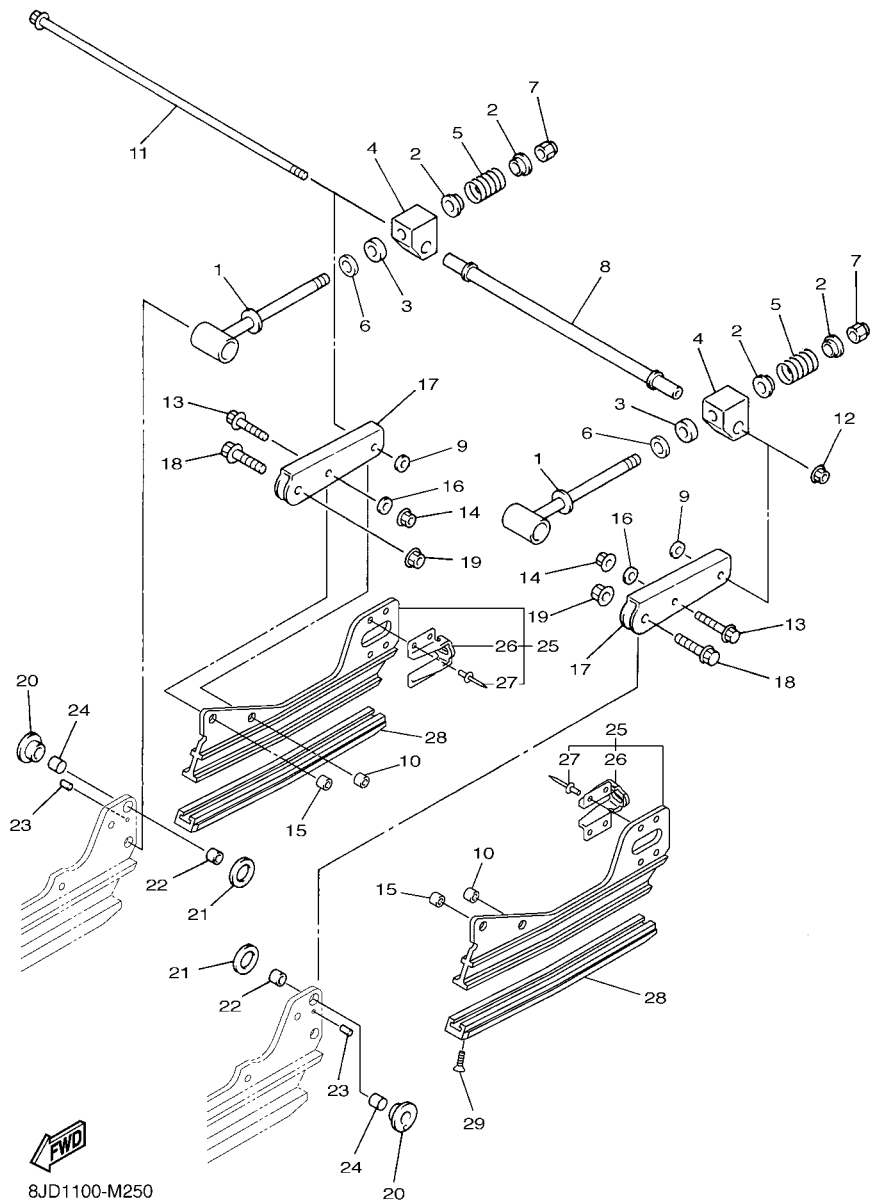

FIG. 29 TRACK SUSPENSION 3

REF. NO.	PART NO.	DESCRIPTION	QTY	QTY		REMARKS
28	8FM-47424-00	RUNNER, SLIDING 4	2	2		
29	90151-06010	SCREW, COUNTERSUNK	2	2		

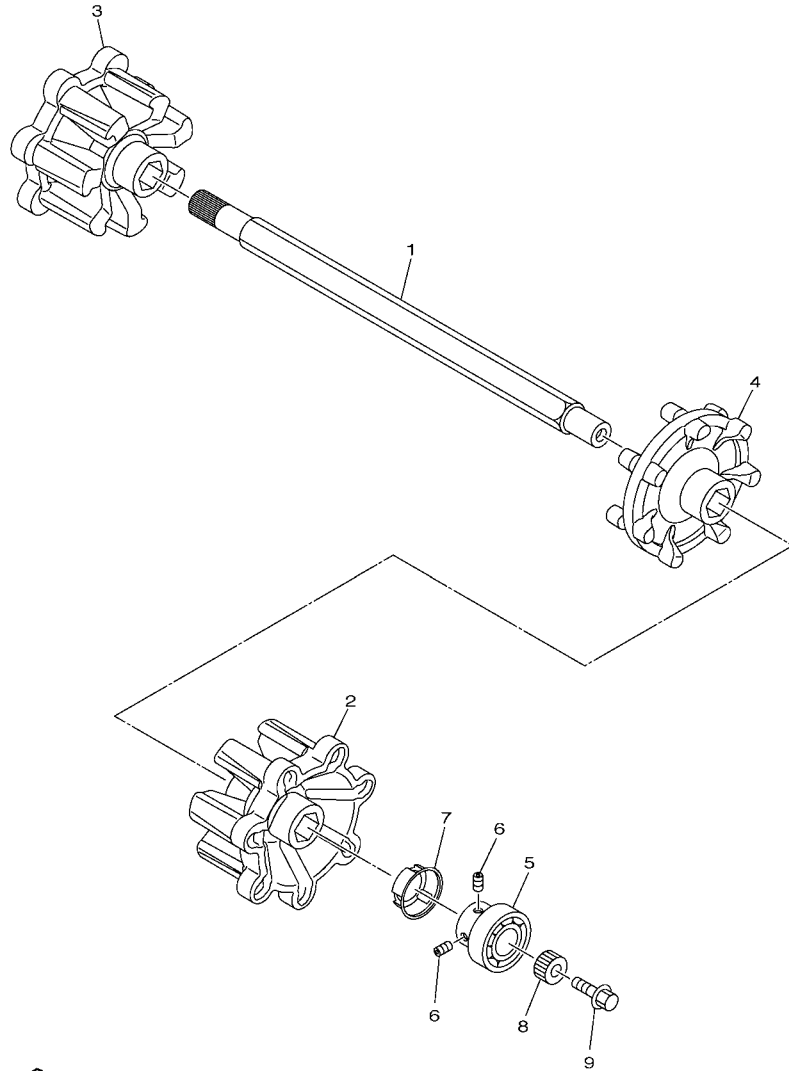

FIG. 30 TRACK DRIVE 1

REF. NO.	PART NO.	DESCRIPTION	8JE2	8JE1	REMARKS
1	8GS-47511-00	AXLE, FRONT	1	1	
2	8JD-47531-00	WHEEL, SPROCKET 1	1	1	
3	8JD-47532-00	WHEEL, SPROCKET 2	1	1	
4	8JD-4753A-00	WHEEL, SPROCKET 3	1	1	
5	93306-20589	BEARING	1	1	
6	90113-06064	BOLT, SET	2	2	
7	8FN-47377-00	CAP	1	1	
8	8EK-47715-00	JOINT	1	1	
9	95822-10025	BOLT, FLANGE	1	1	

FIG. 31 TRACK DRIVE 2

REF. NO.	PART NO.	DESCRIPTION	8JE2	8JE1	REMARKS
1	8GS-47541-00	HOUSING, CHAIN	1	1	
2	93306-20601	BEARING	1	1	
3	93304-20511	BEARING	1	1	
4	93102-30012	OIL SEAL	1	1	
5	93102-35010	OIL SEAL	1	1	
6	99009-62500	CIRCLIP	1	1	
7	99009-52500	CIRCLIP	1	1	
8	8GS-47558-00	RING, HOUSING	1	1	
9	90101-10357	BOLT	1	1	
10	95307-10600	NUT	1	1	
11	93210-25071	O-RING	1	1	
12	90387-2508C	COLLAR	1	1	
13	97002-08014	BOLT	1	1	
14	90210-08017	WASHER, SEAL	1	1	
15	8GS-1761A-00	SHAFT, 1	1	1	
16	8CW-47591-00	PLATE	1	1	
17	90105-060A6	BOLT, FLANGE	4	4	
18	8JE-1761E-00	SHAFT 2	1	1	
19	8GS-47591-00	PLATE	1	1	
20	93306-00208	BEARING	1	1	
21	93102-15212	OIL SEAL	1	1	
22	8GS-18541-01	CAM, SHIFT	1	1	
23	8GS-18191-00	LEVER	1	1	
24	2H9-18154-00	.COVER, DUST	1	1	
25	8GS-18115-00	ROD, SHIFT	1	1	
26	90170-08358	NUT	1	1	
27	95307-08700	NUT	1	1	

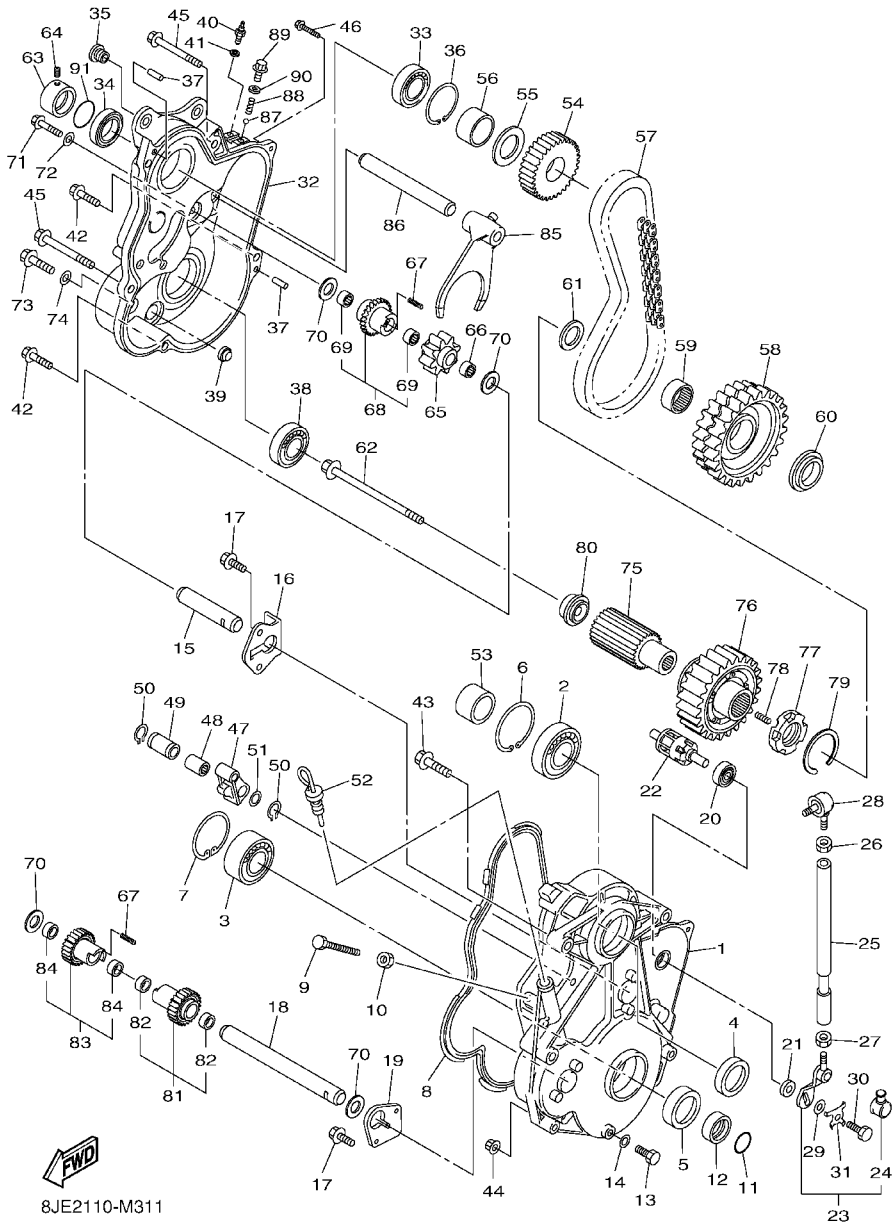
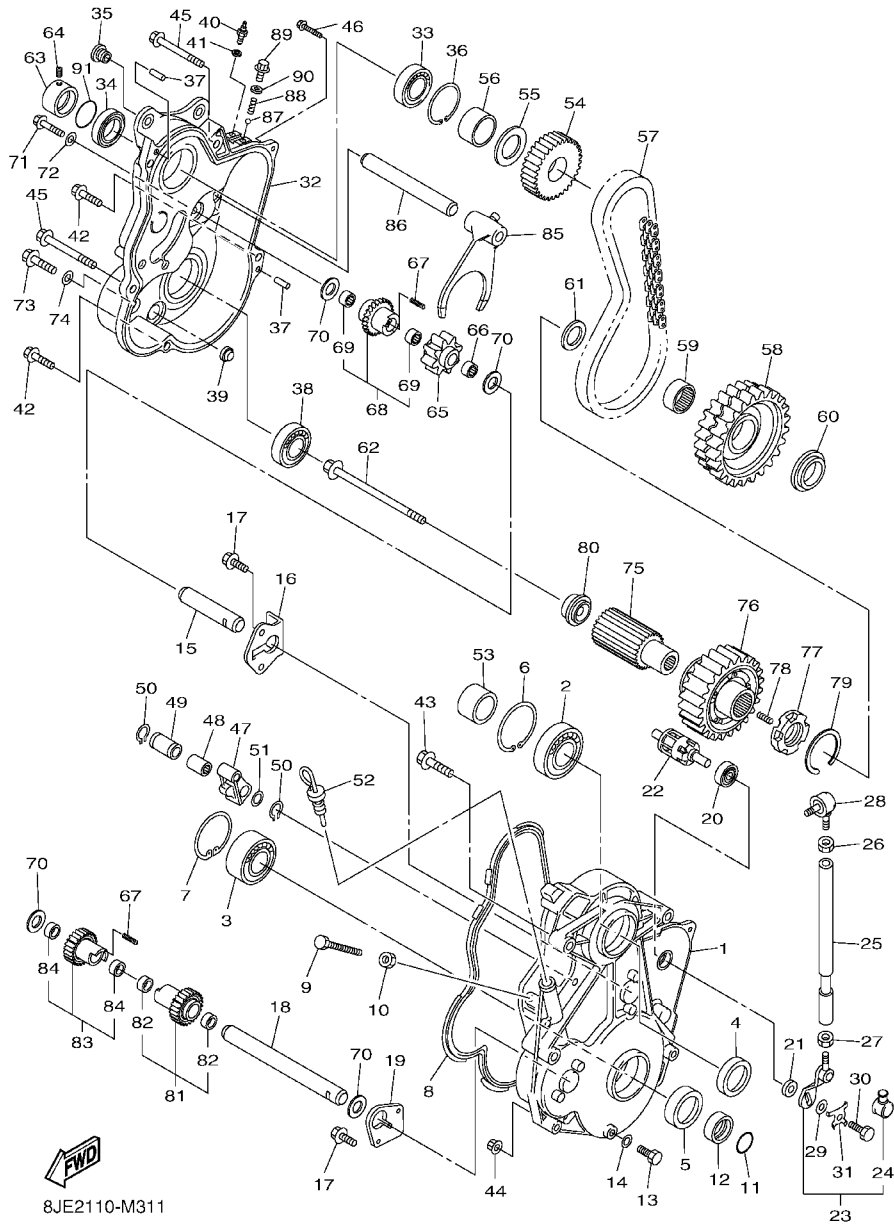
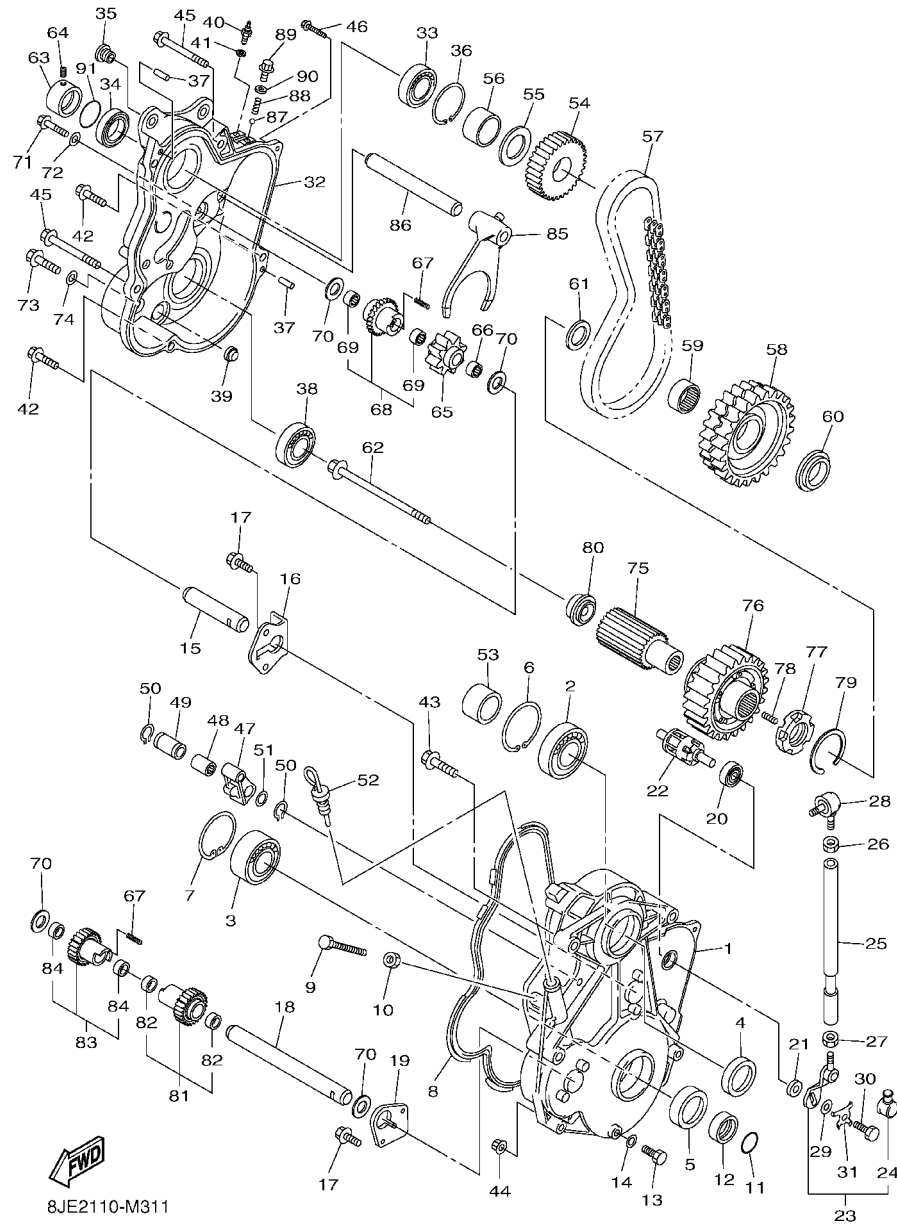

FIG. 31 TRACK DRIVE 2

REF. NO.	PART NO.	DESCRIPTION	QTY	QTY	REMARKS
28	3X3-18157-10	JOINT 2	1	1	
29	90201-06099	WASHER, PLATE	1	1	
30	90101-06047	BOLT	1	1	
31	8GS-47554-01	WASHER, LOCK	1	1	
32	8GS-47543-10	CAP, HOUSING	1	1	
33	93306-20511	BEARING	1	1	
34	93102-35010	OIL SEAL	1	1	
35	90179-10679	NUT	2	2	
36	99009-52500	CIRCLIP	1	1	
37	93606-20044	PIN, DOWEL	2	2	
38	93306-00711	BEARING	1	1	
39	3Y1-15361-00	GAUGE, LEVEL	1	1	
40	5LP-82540-01	NEUTRAL SWITCH ASSY	1	1	
41	90430-10148	GASKET	1	1	
42	95822-08030	BOLT, FLANGE	3	3	
43	95822-10045	BOLT, FLANGE	2	2	
44	95602-10200	NUT, U FLANGE	1	1	
45	95822-10090	BOLT, FLANGE	2	2	
46	95822-06025	BOLT, FLANGE	1	1	
47	8ES-47613-00	HOLDER	1	1	
48	93311-32685	BEARING	1	1	
49	90387-22005	COLLAR	1	1	
50	99009-26400	CIRCLIP	2	2	
51	90201-266P2	WASHER, PLATE	1	1	
52	8GS-47546-00	LEVEL, OIL	1	1	
53	90387-30005	COLLAR	1	1	
54	8FA-17682-00	SPROCKET, CHAIN DRIVE (20T)	1	1	



8JE2110-M311



8JE2110-M311

FIG. 31 TRACK DRIVE 2

REF. NO.	PART NO.	DESCRIPTION	8JE2	8JE1	REMARKS
55	90208-26002	WASHER, CONICAL SPRING	1	1	
56	90387-26007	COLLAR	1	1	
57	94890-09068	CHAIN (68L)	1	1	
58	8JE-47587-00	SPROCKET, CHAIN DRIVEN	1	1	
59	93317-33179	BEARING	1	1	
60	90387-2008G	COLLAR	1	1	
61	90201-320S3	WASHER, PLATE	1	1	
62	90105-10223	BOLT, FLANGE	1	1	
63	90387-25018	COLLAR	1	1	
64	90113-06064	BOLT, SET	1	1	
65	8FB-17692-00	SPROCKET, DRIVE (18T)	1	1	
66	93317-21578	BEARING	1	1	
67	90501-050A0	SPRING, COMPRESSION	2	2	
68	8JE-1714A-00	REVERSE PINION ASSY.	1	1	
69	93317-21578	.BEARING	2	2	
70	90201-16245	WASHER, PLATE	4	4	
71	90105-060A6	BOLT, FLANGE	1	1	
72	90210-06006	WASHER, SEAL	1	1	
73	90105-08153	BOLT, FLANGE	1	1	
74	90210-08017	WASHER, SEAL	1	1	
75	8GS-47571-00	JOURNAL 1	1	1	
76	8JE-17243-00	GEAR, REVERSE WHEEL 1	1	1	
77	8CW-17492-00	DOG, TRANSMISSION SHIFT	1	1	
78	90501-066J5	SPRING, COMPRESSION	5	5	
79	93440-39175	CIRCLIP	1	1	
80	8GS-47564-00	COLLAR	1	1	
81	8GS-17210-00	1ST WHEEL GEAR ASSY	1	1	

FIG. 31 TRACK DRIVE 2

REF. NO.	PART NO.	DESCRIPTION	8JE2	8JE1	REMARKS
82	93317-21578	.BEARING	2	2	
83	8JE-17110-00	1ST PINION GEAR ASSY	1	1	
84	93317-21578	.BEARING	2	2	
85	8GS-18511-00	FORK, SHIFT 1	1	1	
86	8GS-18531-00	BAR, SHIFT FORK GUIDE 1	1	1	
87	93503-08007	BALL	1	1	
88	90501-10353	SPRING, COMPRESSION	1	1	
89	90105-14003	BOLT, FLANGE	1	1	
90	90430-14043	GASKET	1	1	
91	93210-25642	O-RING	1	1	

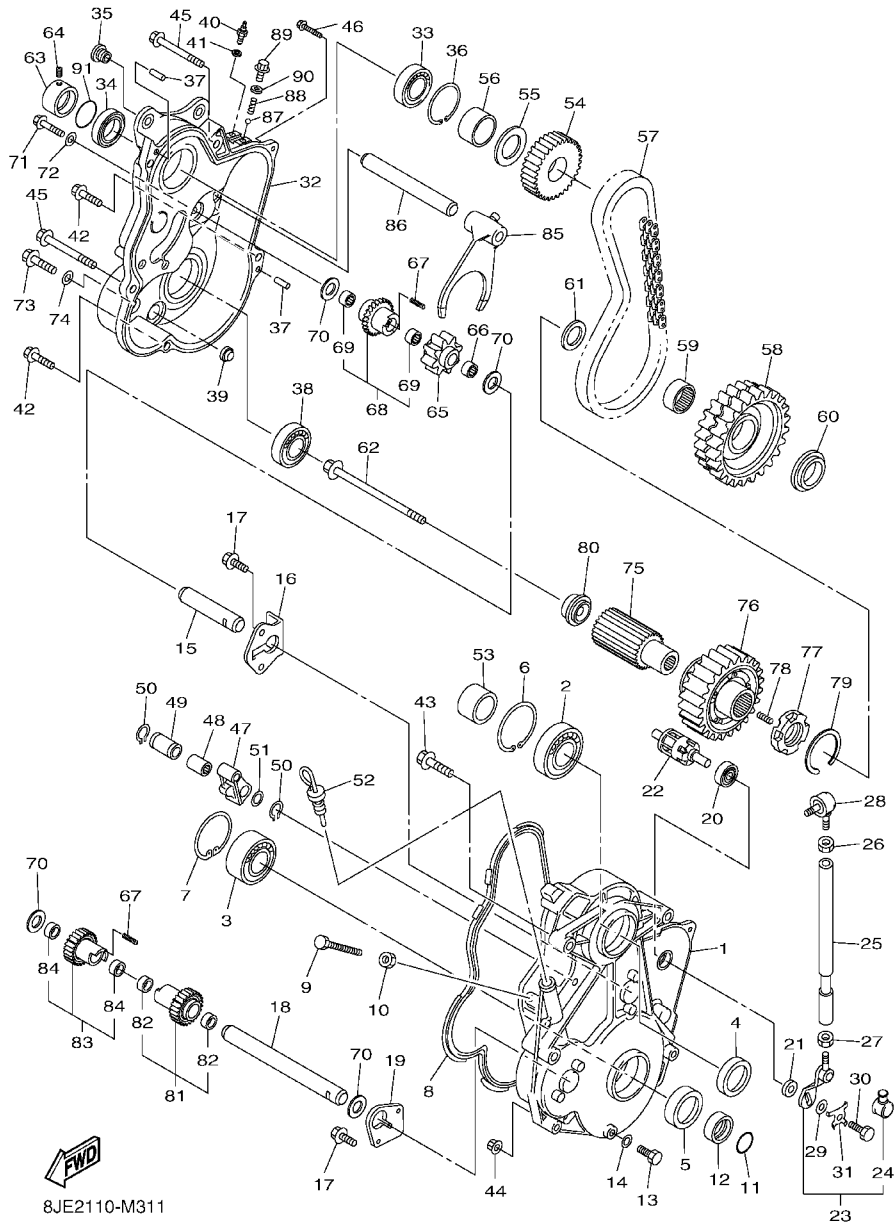

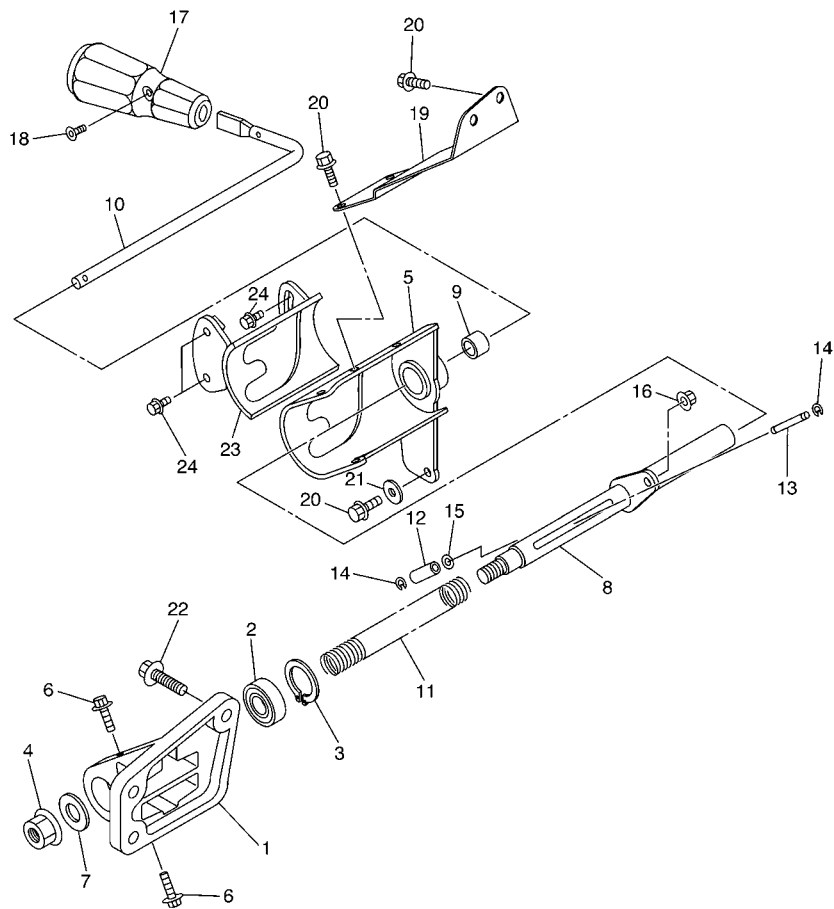

8GS3100-G320

FIG. 32 TRACK DRIVE 3

REF. NO.	PART NO.	DESCRIPTION	8/E2	8/E1	REMARKS
1	8GS-18164-00	KNOB, SHIFTER	1	1	
2	93306-20212	BEARING	1	1	
3	99009-35500	CIRCLIP	1	1	
4	95607-12200	NUT, SELF-LOCKING	1	1	
5	8GS-18161-01	GUIDE, PLATE STOPPER	1	1	
6	95827-08016	BOLT, FLANGE	2	2	
7	90201-12317	WASHER, PLATE	1	1	
8	8GS-18104-01	SHIFT GUIDE COMP.	1	1	
9	90384-19001	BUSH, BIMETAL FORMED	1	1	
10	8GS-18152-01	LEVER, SHIFT 4	1	1	
11	90501-130A0	SPRING, COMPRESSION	1	1	
12	90387-06059	COLLAR	1	1	
13	90249-06002	PIN	1	1	
14	93410-06053	CIRCLIP	2	2	
15	90201-06042	WASHER, PLATE	1	1	
16	95602-06200	NUT, SELF-LOCKING	1	1	
17	8GS-18174-00	KNOB, SHIFT LEVER	1	1	
18	90151-05048	SCREW, COUNTERSUNK	1	1	
19	8GS-18128-01	BRACKET	1	1	
20	95822-08014	BOLT, FLANGE	5	5	
21	90201-08060	WASHER, PLATE	1	1	
22	95822-08020	BOLT, FLANGE	3	3	
23	8GS-18179-01	GUIDE	1	1	
24	95812-06012	BOLT, FLANGE	3	3	

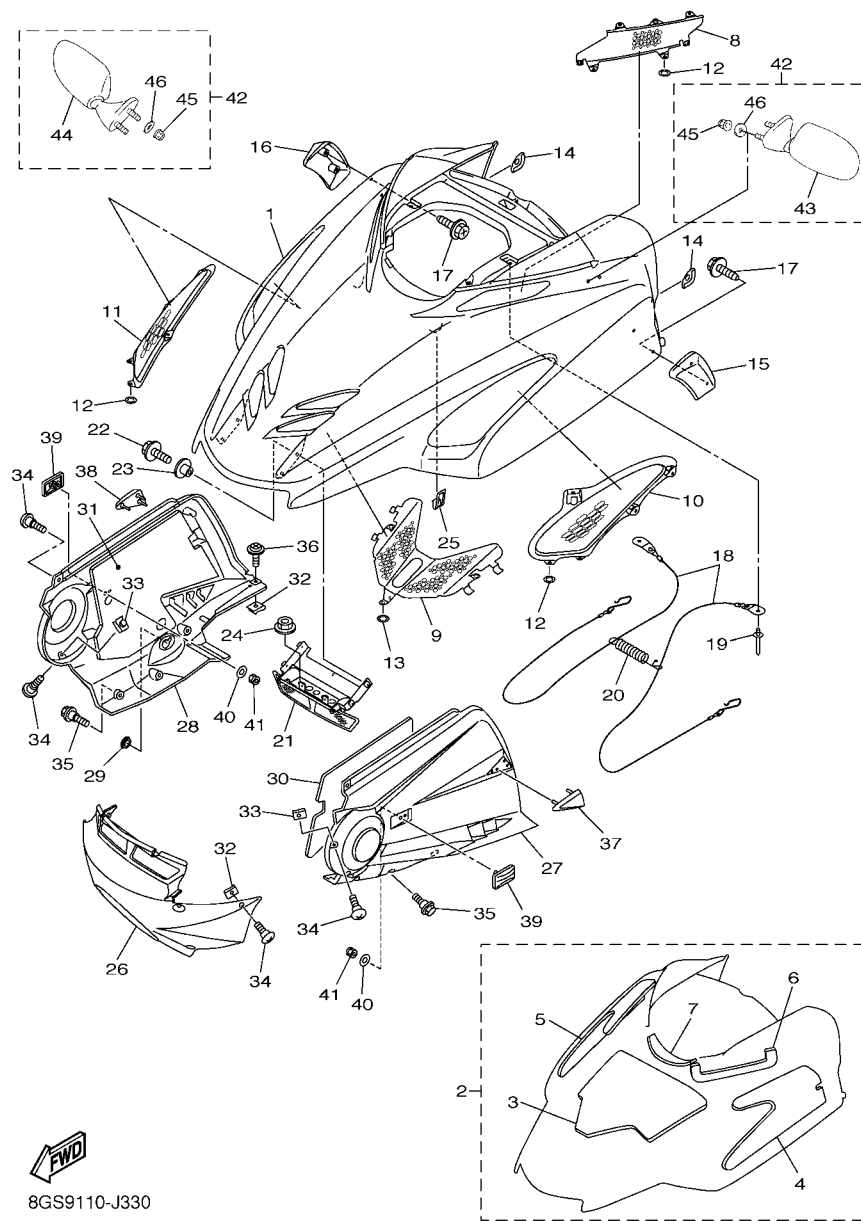

8GS9110-J330

FIG. 33 SHROUD

REF. NO.	PART NO.	DESCRIPTION	8/E2	8/E1	REMARKS
1	8FN-77111-00-P6	SHROUD	1	1	DGNM3
2	8FN-W7726-00	LINING SET	1	1	
3	8FN-77271-00	.DAMPER, NOISE 11	1	1	
4	8FN-77272-00	.DAMPER, NOISE 12	1	1	
5	8FN-77273-00	.DAMPER, NOISE 13	1	1	
6	8FN-77264-00	.LINING, SHROUD 4	1	1	
7	8DS-84366-00	.DAMPER, HEADLIGHT 1	1	1	
8	8FN-77130-00	LOUVER COMP.	1	1	
9	8FN-77134-00	LOUVER 4	1	1	
10	8FN-77109-00	LOUVER 5	1	1	
11	8FN-77108-00	LOUVER 6	1	1	
12	90183-05068	NUT, SPRING	14	14	
13	90183-08065	NUT, SPRING	3	3	
14	8FA-77167-10	TRIM 3	2	2	
15	8FN-77161-00	STRIP, WEATHER 1	1	1	
16	8FN-77162-00	STRIP, WEATHER 2	1	1	
17	97702-50016	SCREW, TAPPING	4	4	
18	8FN-77118-00	STOPPER, SHROUD	2	2	
19	90267-48018	RIVET, BLIND (4.8X18.6 BLACK)	2	2	
20	89A-77159-00	CLAMP, ROD	2	2	
21	8FN-77140-00	HINGE ASSY	1	1	
22	95802-06016	BOLT, FLANGE	4	4	
23	90387-06681	COLLAR	4	4	
24	95602-06200	NUT, SELF-LOCKING	2	2	
25	8FA-77135-00	CLAMP 1	1	1	
26	8FN-21912-00	PANEL, SUB FRAME 1	1	1	
27	8ES-2197H-01	HOOD 3	1	1	

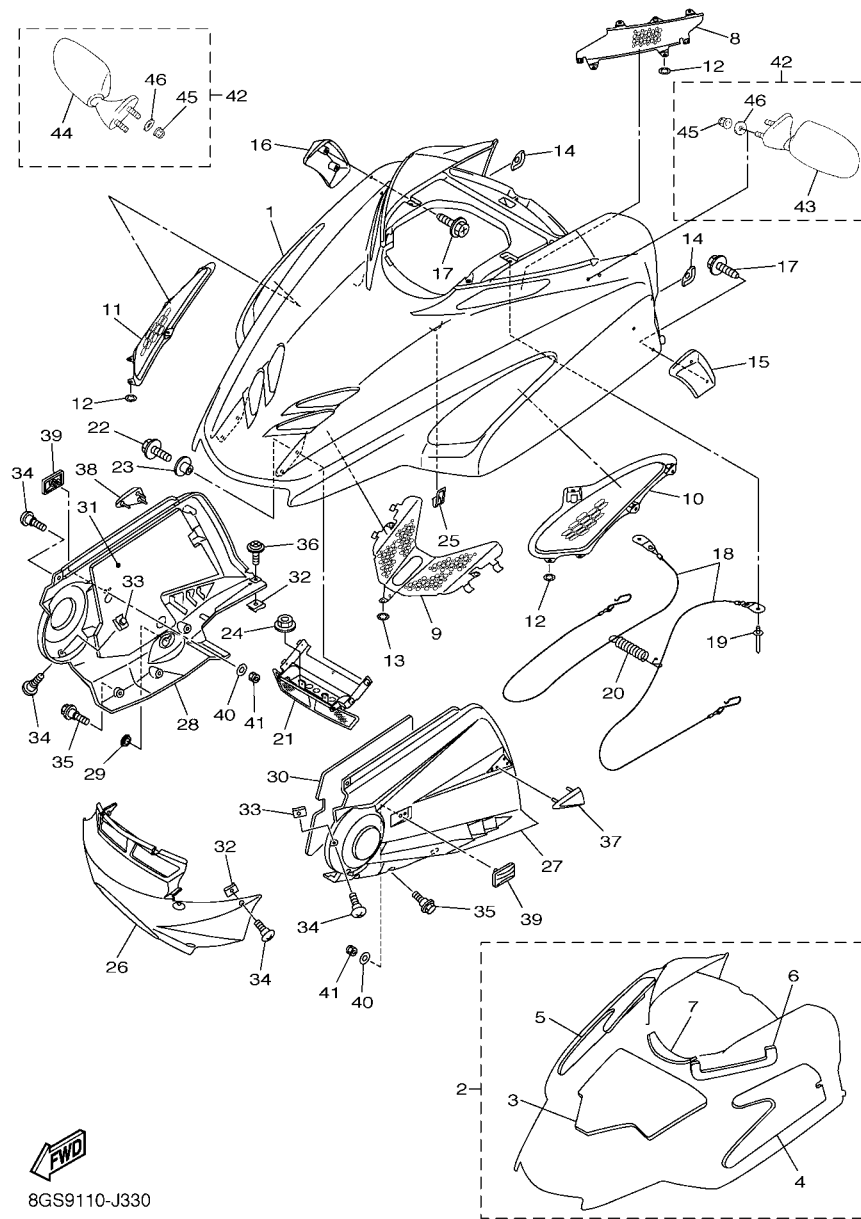

8GS9110-J330

FIG. 33 SHROUD

REF. NO.	PART NO.	DESCRIPTION	QTY	QTY	REMARKS
28	8GS-2198H-00	HOOD 4	1	1	
29	90338-30256	PLUG	1	1	
30	8ES-77276-00	DAMPER, NOISE 16	1	1	
31	8GS-77277-00	DAMPER, NOISE 17	1	1	
32	90183-06053	NUT, SPRING	8	8	
33	90183-06100	NUT, SPRING	6	6	
34	90154-06009	SCREW, BINDING	12	12	
35	90109-06220	BOLT	6	6	
36	90159-06011	SCREW, WITH WASHER	2	2	
37	8FA-77561-00	PROTECTOR, SIDE 1	1	1	
38	8FA-77562-00	PROTECTOR, SIDE 2	1	1	
39	8FR-77185-00	PLATE 1	2	2	
40	90201-05036	WASHER, PLATE	2	2	
41	95702-05300	NUT, NYLON	2	2	
42	8CR-W2628-10	REAR VIEW MIRROR SET	1	1	
43	4SV-26280-00	.REAR VIEW MIRROR ASSY (LEFT)	1	1	
44	4SV-26290-00	.REAR VIEW MIRROR ASSY (RIGHT)	1	1	
45	95602-06200	.NUT, SELF-LOCKING	4	4	
46	90201-06072	.WASHER, PLATE	4	4	

FIG. 34 EMBLEM

REF. NO.	PART NO.	DESCRIPTION	8J/E2	8J/E1		REMARKS
1	8JE-77141-00	EMBLEM 1	2	2		
2	8JE-7711L-00	GRAPHIC, SHROUD	1	1		
3	8JE-7711M-00	GRAPHIC, SHROUD	1	1		
4	8JE-7715A-00	EMBLEM 3D	2	2		
5	8AC-2414B-01	EMBLEM	1	1		
6	8DM-77761-E0	LABEL, WARNING 1	1			
	8DM-77761-S0	LABEL, WARNING 1		1		UR FOR EUR
	8GS-77761-R1	LABEL, WARNING 1		1		UR FOR RUS
	8BY-77761-J0	LABEL, WARNING 1		1		UR FOR JPN
7	8FN-77761-E0	LABEL, WARNING 1	1			
	8FN-77761-S0	LABEL, WARNING 1		1		UR FOR EUR
	8FN-77761-R1	LABEL, WARNING 1		1		UR FOR RUS
	8FN-77761-J0	LABEL, WARNING 1		1		UR FOR JPN
8	8GS-77763-E0	LABEL, WARNING 3	1			
	8GS-77763-S0	LABEL, WARNING 3		1		UR FOR EUR,RUS
	8GS-77763-J0	LABEL, WARNING 3		1		UR FOR JPN
9	8ET-2815K-00	LABEL, NOTICE WINDSHIELD 1	1			
10	8ET-2815K-10	LABEL, NOTICE WINDSHIELD 1	1			
11	99246-00200	EMBLEM, YAMAHA	2	2		

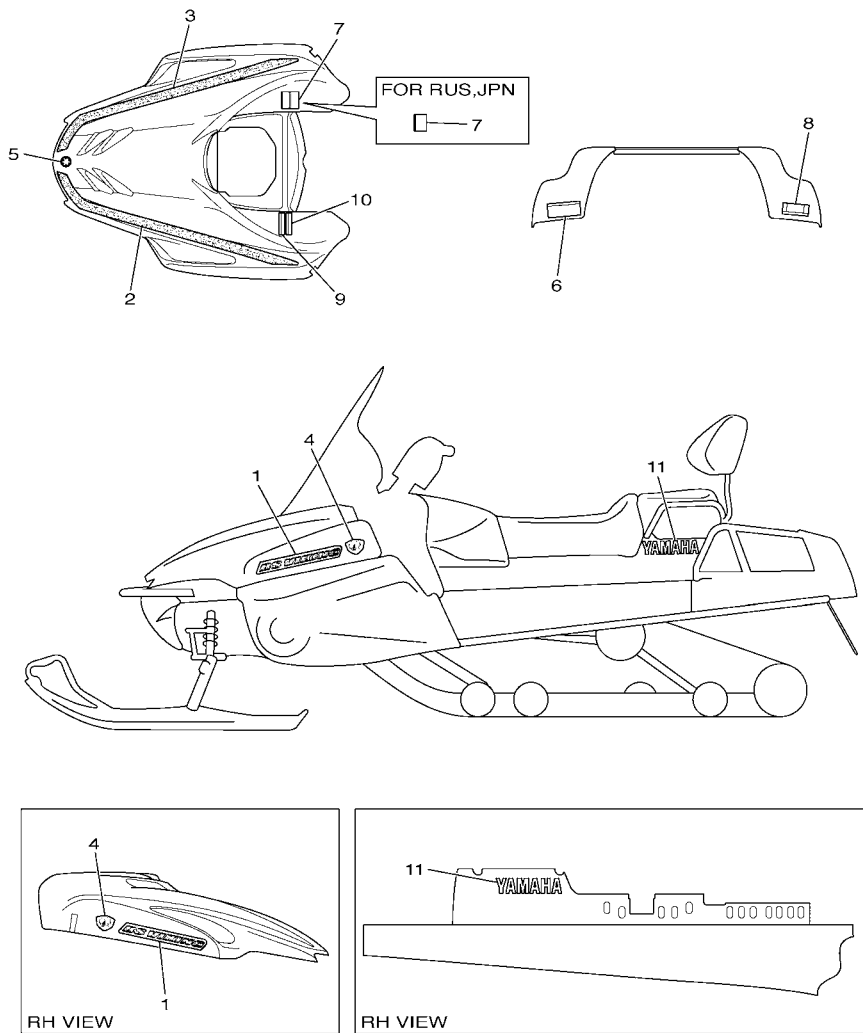

8JE2100-M340

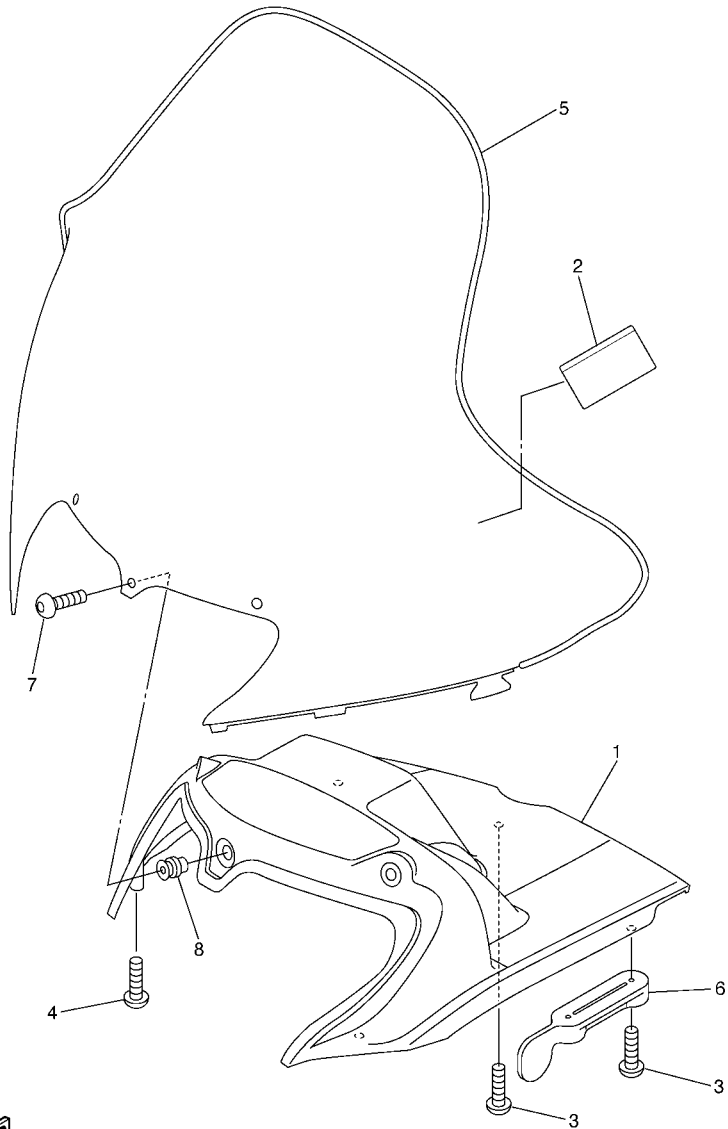

8FN1100-E340

FIG. 35 WINDSHIELD

REF. NO.	PART NO.	DESCRIPTION	8J/E2	8J/E1	REMARKS
1	8FN-77251-00	COVER, HEADLIGHT	1	1	
2	4B5-2815K-20	LABEL, NOTICE WINDSHIELD 1		1	FOR JPN
3	97702-50016	SCREW, TAPPING	3	3	
4	97702-50020	SCREW, TAPPING	2	2	
5	8FN-K7210-00	WINDSHIELD COMP.	1		
---	8FN-77210-00	WINDSHIELD COMP.	---	1	---
6	82H-77223-00	FASTNER	2	2	
7	90149-05299	SCREW	3	3	
8	90179-05523	NUT	3	3	
---	---	---	---	---	---
---	---	---	---	---	---
---	---	---	---	---	---
---	---	---	---	---	---
---	---	---	---	---	---
---	---	---	---	---	---
---	---	---	---	---	---

FIG. 36 GUARD & LUGGAGE BOX

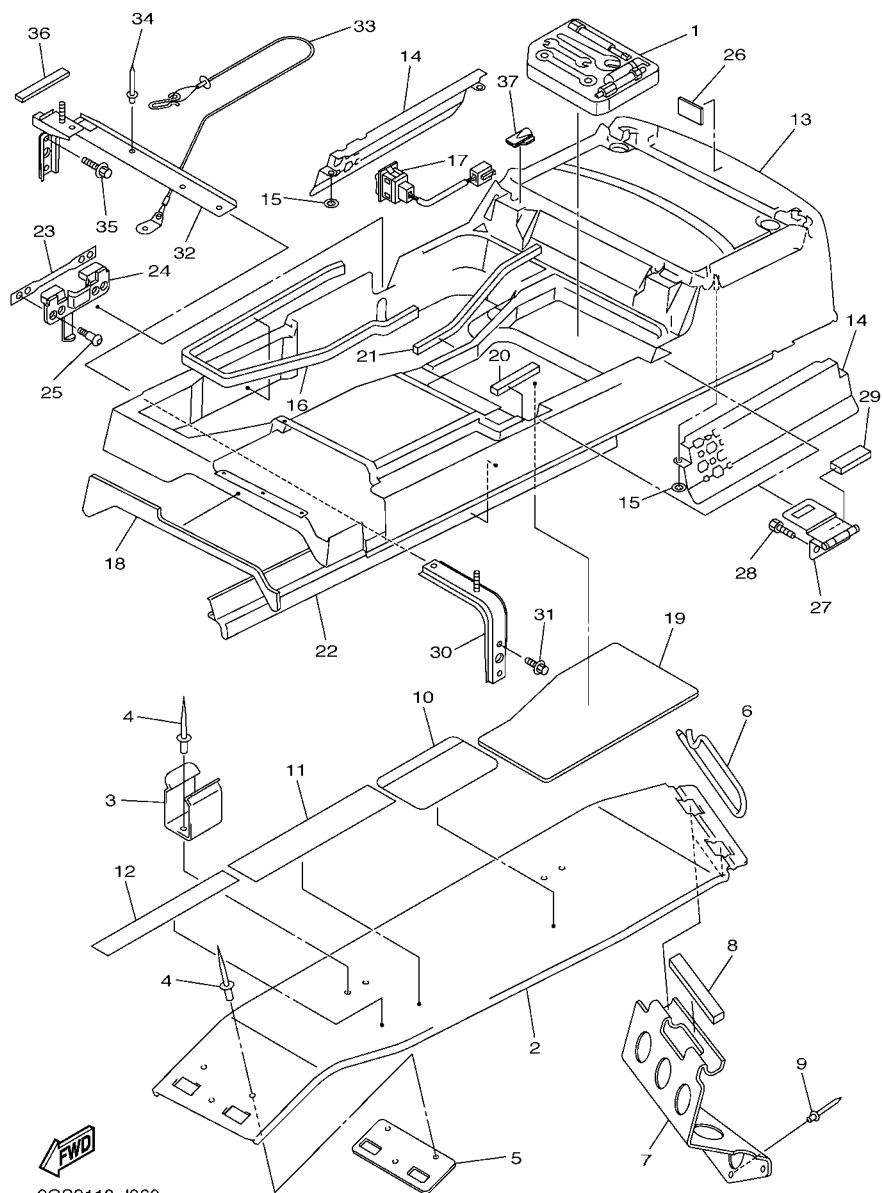

8GS9110-J360

REF. NO.	PART NO.	DESCRIPTION	8/E2	8/E1	REMARKS
1	8FN-28100-01	TOOL KIT	1	1	
2	8FA-77311-02	GUARD, DRIVE	1	1	
3	8CR-77338-00	STAY, BELT	2	2	
4	90267-48010	RIVET, BLIND (4.8X12 YELLOW)	7	7	
5	8FA-77373-00	PROTECTOR	1	1	
6	8CR-77384-01	PIN	1	1	
7	8FN-21973-00	HOOK	1	1	
8	8CR-77319-00	DAMPER 1	1	1	
9	90267-47195	RIVET, BLIND(4.7X16.4 YELLOW)	3	3	
10	8BD-77762-00	LABEL, WARNING 2	1		
	86D-77762-00	LABEL, WARNING 2	1		UR FOR EUR
	8AC-77762-R1	LABEL, WARNING 2	1		UR FOR RUS
	8BD-77762-21	LABEL, WARNING 2	1		UR FOR JPN
11	8JD-47578-00	LABEL 1	1	1	EXCEPT FOR JPN
12	8ES-1417E-00	LABEL, CAUTION	1	1	
13	8FN-77390-00	LUGGAGE BOX ASSY	1	1	
14	8FN-77133-00	LOUVER 3	2	2	
15	90183-05068	NUT, SPRING	4	4	
16	8FN-2414G-00	SEAL	1	1	
17	8ET-82917-00	SWITCH	1	1	
18	8FN-77262-00	LINING, SHROUD 2	1	1	
19	8FN-77263-00	LINING, SHROUD 3	1	1	
20	8FN-241A3-00	SEAL 3	1	1	
21	8FN-241A4-00	SEAL 4	1	1	
22	8FN-2196T-00	TRIM 1	2	2	
23	8FN-2478C-00	BAR, SEAT LEVER	1	1	
24	8FN-24723-00	DAMPER, SEAT	1	1	

FIG. 36 GUARD & LUGGAGE BOX

REF. NO.	PART NO.	DESCRIPTION	8/JE2	8/JE1	REMARKS
25	90111-05020	BOLT,HEX. SOCKET BUTTON	4	4	
26	5TG-84163-00	DAMPER	1	1	
27	8FN-24772-00	HINGE ASSY	2	2	
28	90110-06043	BOLT, HEXAGON SOCKET HEAD	4	4	
29	8FN-2414E-00	SEAL 2	2	2	
30	8FN-2194N-01	BRACKET, FUEL TANK 1	1	1	
31	95812-08014	BOLT, FLANGE	2	2	
32	8FN-2194R-01	BRACKET, FUEL TANK 2	1	1	
33	8FN-2478E-00	CABLE, SEAT LOCK	1	1	
34	90267-47186	RIVET, BLIND (4.7X16.4 BLACK)	1	1	
35	95812-08014	BOLT, FLANGE	3	3	
36	8FN-241A3-00	SEAL 3	1	1	
37	8FN-24742-00	GROMMET	1	1	

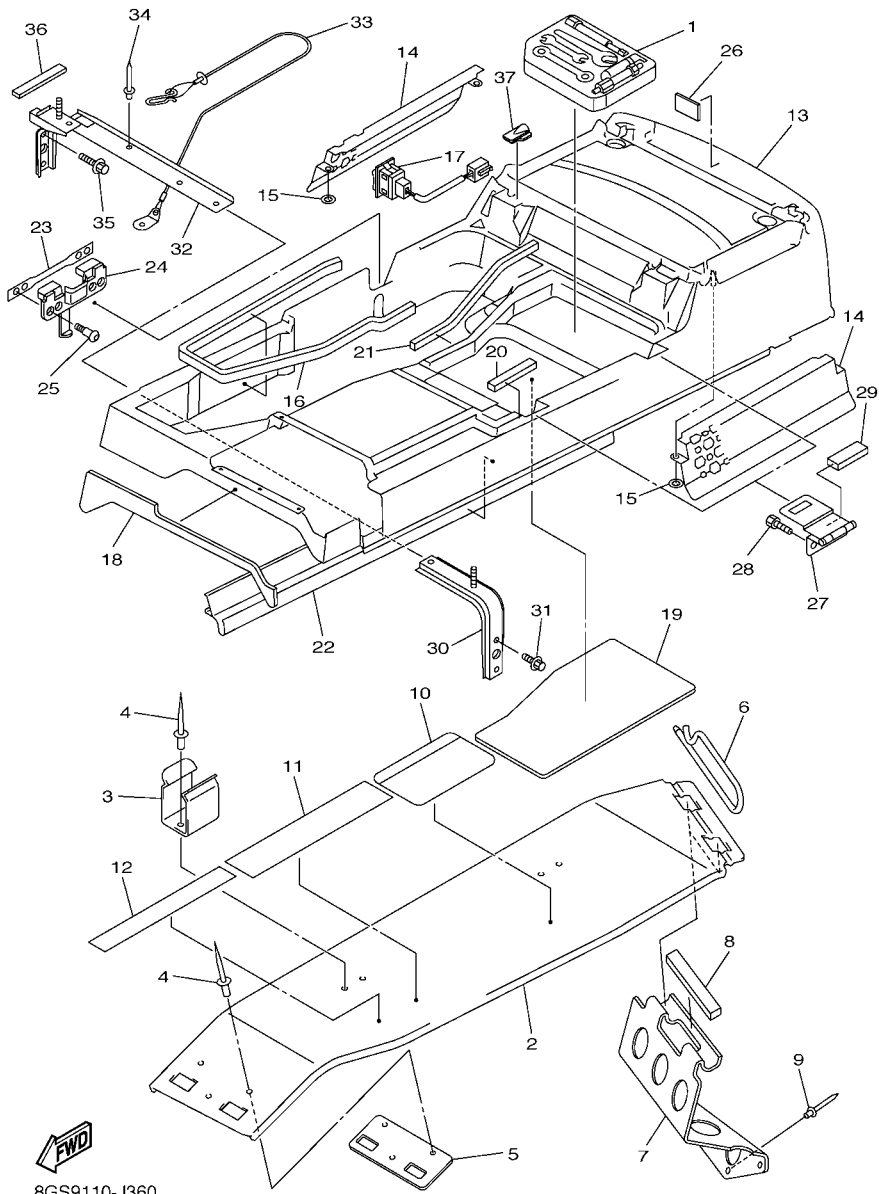

8GS9110-J360

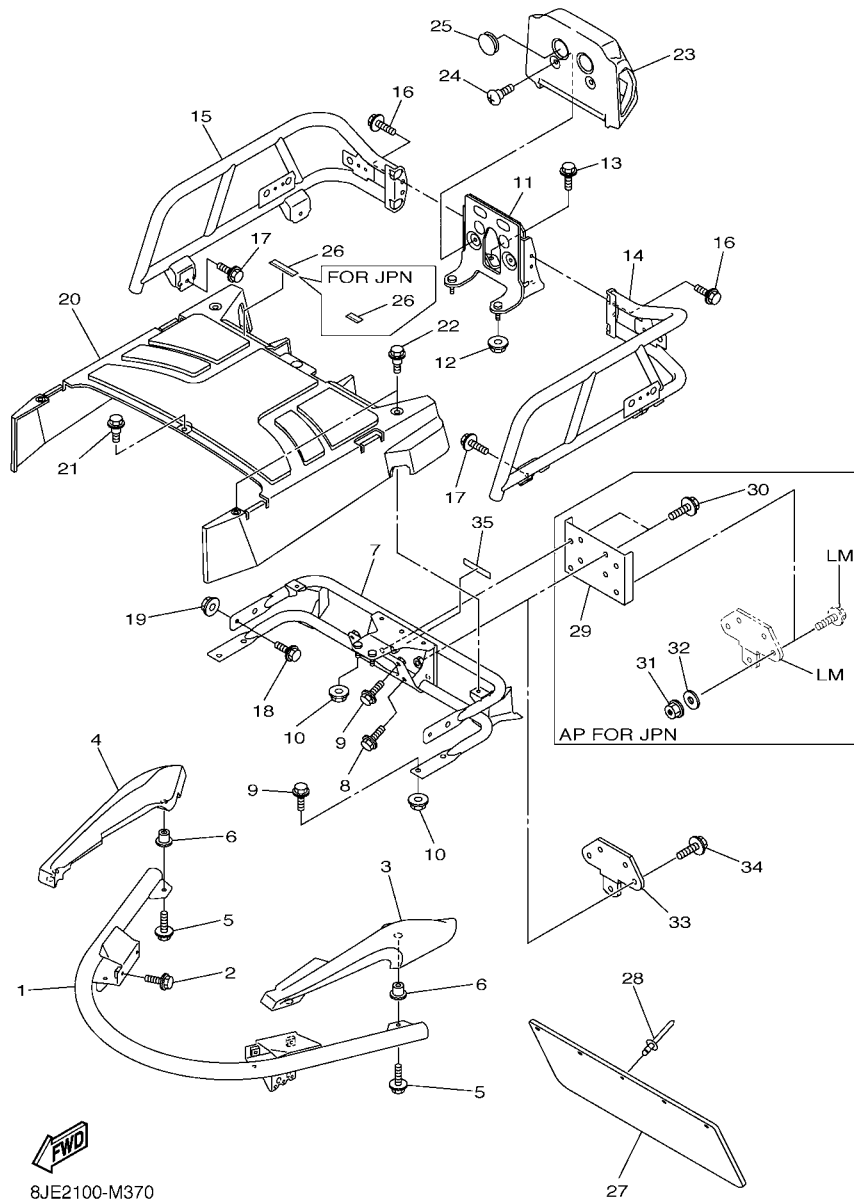

8JE2100-M370

FIG. 37 BUMPER

REF. NO.	PART NO.	DESCRIPTION	8JE2	8JE1	REMARKS
1	8FN-77511-20	BUMPER, FRONT 1	1	1	
2	95822-08020	BOLT, FLANGE	4	4	
3	8FN-77523-00	END, BUMPER	1	1	
4	8FN-77524-00	END, BUMPER	1	1	
5	95822-06020	BOLT, FLANGE	4	4	
6	90179-06520	NUT	4	4	
7	8FN-77541-00	BUMPER, REAR 1	1	1	
8	95822-10020	BOLT, FLANGE	2	2	
9	95822-08016	BOLT, FLANGE	6	6	
10	95702-08500	NUT, FLANGE	6	6	
11	8FN-77542-00	BUMPER, REAR 2	1	1	
12	95702-08500	NUT, FLANGE	2	2	
13	95812-08016	BOLT, FLANGE	2	2	
14	8JE-77543-00	BUMPER, REAR 3	1	1	
15	8JE-77544-00	BUMPER, REAR 4	1	1	
16	95827-08016	BOLT, FLANGE	4	4	
17	95822-10020	BOLT, FLANGE	4	4	
18	95802-06014	BOLT, FLANGE	2	2	
19	95702-06500	NUT, FLANGE	2	2	
20	8FN-77551-00	PROTECTOR 1	1	1	
21	90109-06272	BOLT	1	1	
22	90109-063F1	BOLT	4	4	
23	8FN-77552-00	PROTECTOR 2	1	1	
24	90154-06009	SCREW, BINDING	2	2	
25	90338-28242	PLUG	2	2	
26	8FM-24897-01	EMBLEM	1		
	8FM-24897-11	EMBLEM		1	UR FOR EUR,RUS

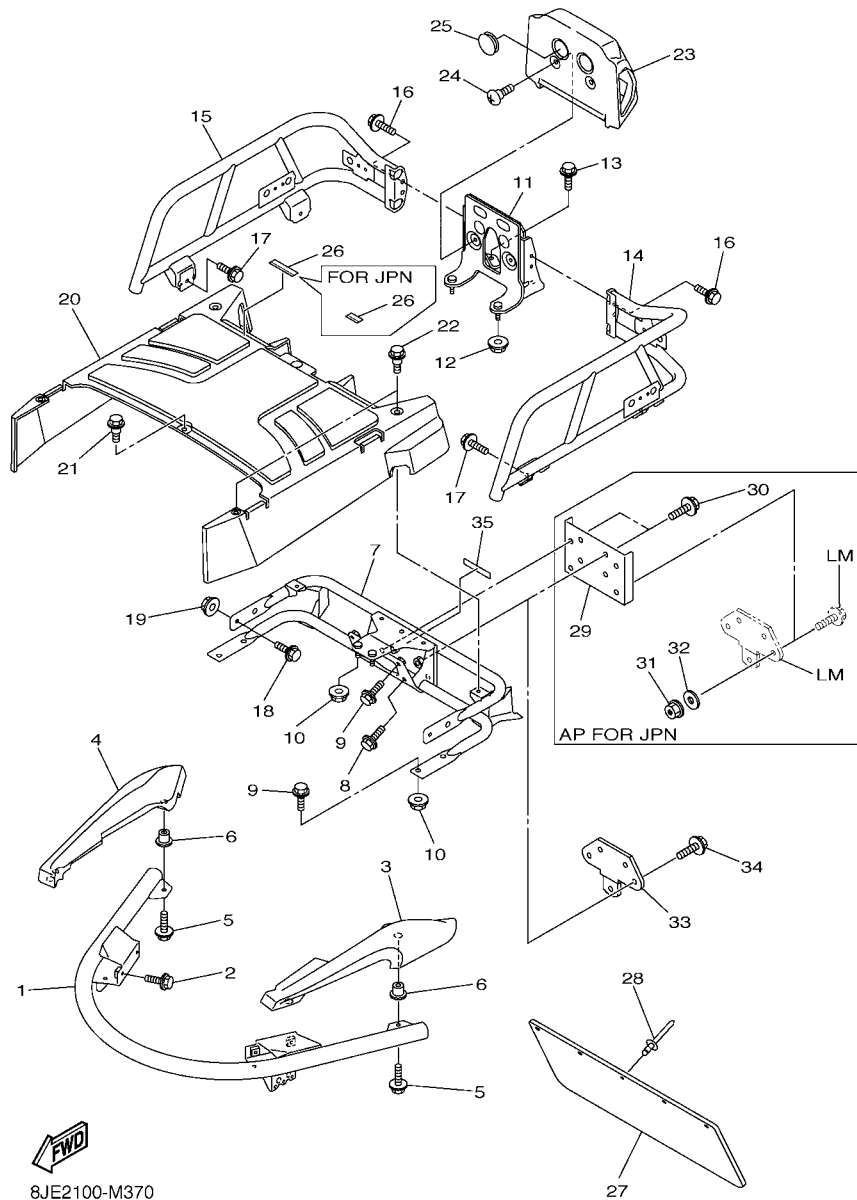

8JE2100-M370

FIG. 37 BUMPER

REF. NO.	PART NO.	DESCRIPTION	8JE2	8JE1	REMARKS
26	4KN-24877-C0	LABEL, CAUTION		1	UR FOR JPN
27	83R-77595-00	FLAP	1	1	
28	90267-48086	RIVET, BLIND (4.8X19 BLACK)	5	5	
29	80M-77591-00	BRACKET, HITCH 1	1		AP FOR JPN
30	95822-08025	BOLT, FLANGE	4		AP FOR JPN
31	95712-08300	NUT, FLANGE	4		AP FOR JPN
32	92902-08600	WASHER, PLATE	4		AP FOR JPN
33	84R-77592-00	BRACKET, HITCH 2	1		
34	95827-08025	BOLT, FLANGE	4		
35	8GS-2817S-E0	LABEL, PULLING LOAD LIMIT	1		
	8HF-2817S-00	LABEL, PULLING LOAD LIMIT	1		UR FOR EUR,RUS
	8GS-2817S-J0	LABEL, PULLING LOAD LIMIT	1		UR FOR JPN

FIG. 38 INSTRUMENT PANEL

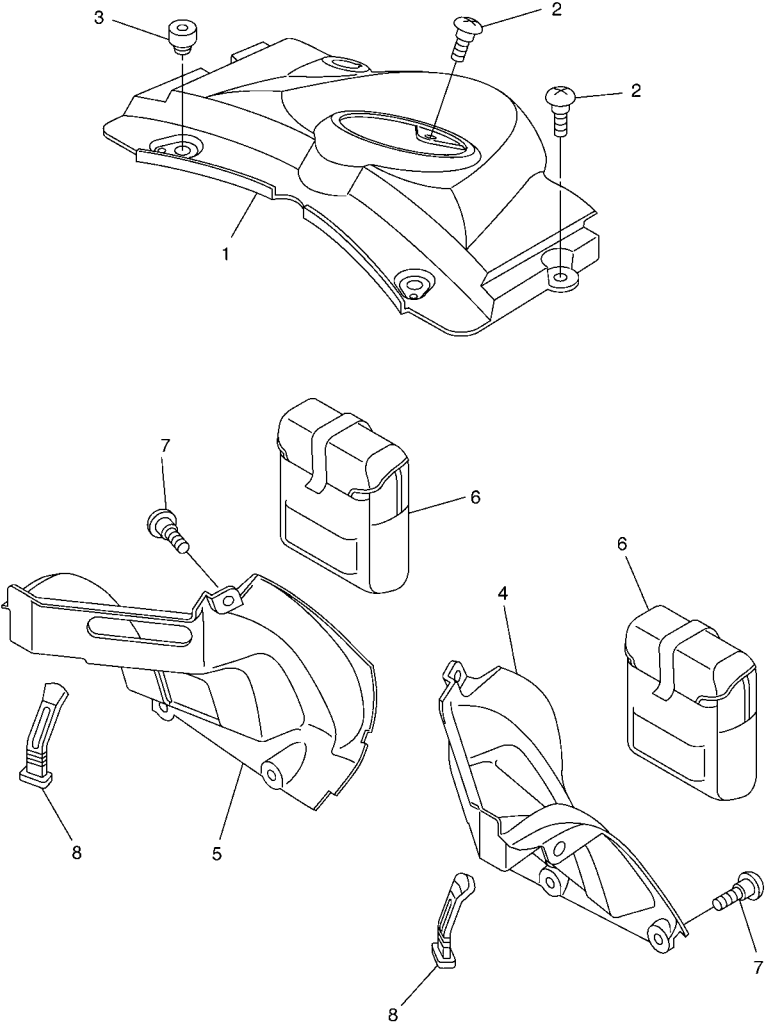

REF. NO.	PART NO.	DESCRIPTION	8/E2	8/E1	REMARKS
1	8FN-77711-00	PANEL, INSTRUMENT	1	1	
2	90149-06263	SCREW	3	3	
3	4N0-27114-00	STOPPER, MAIN STAND	2	2	
4	8FN-77131-00	LOUVER 1	1	1	
5	8FN-77132-00	LOUVER 2	1	1	
6	8GS-77735-00	BOX, GLOVE	2	2	
7	90154-06009	SCREW, BINDING	6	6	
8	8FA-77171-00	BODY, LATCH 1	2	2	

 8FN1100-E370

FIG. 39 GENERATOR

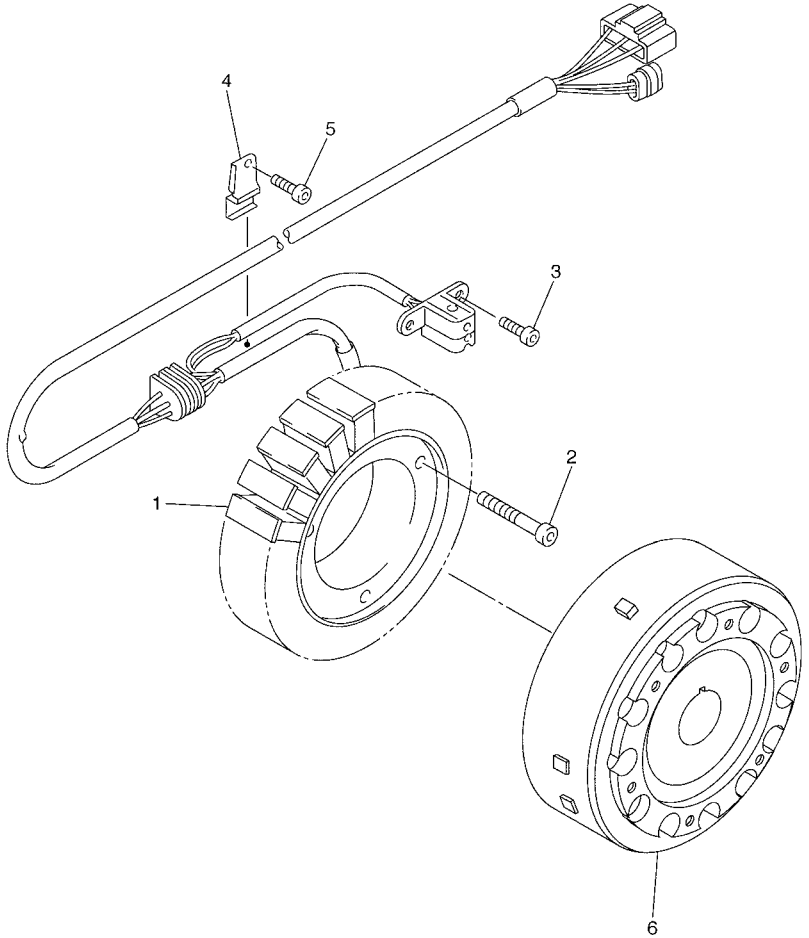

REF. NO.	PART NO.	DESCRIPTION	QTY	UNIT	REMARKS
1	8ES-81410-01	STATOR ASSY	1	1	
2	90110-06223	BOLT, HEXAGON SOCKET HEAD	3	3	
3	90110-05034	BOLT, HEXAGON SOCKET HEAD	2	2	
4	8FA-15113-00	PLATE	1	1	
5	90110-06187	BOLT, HEXAGON SOCKET HEAD	1	1	
6	8ES-81450-01	ROTOR ASSY	1	1	

FWD
8ES1100-D370

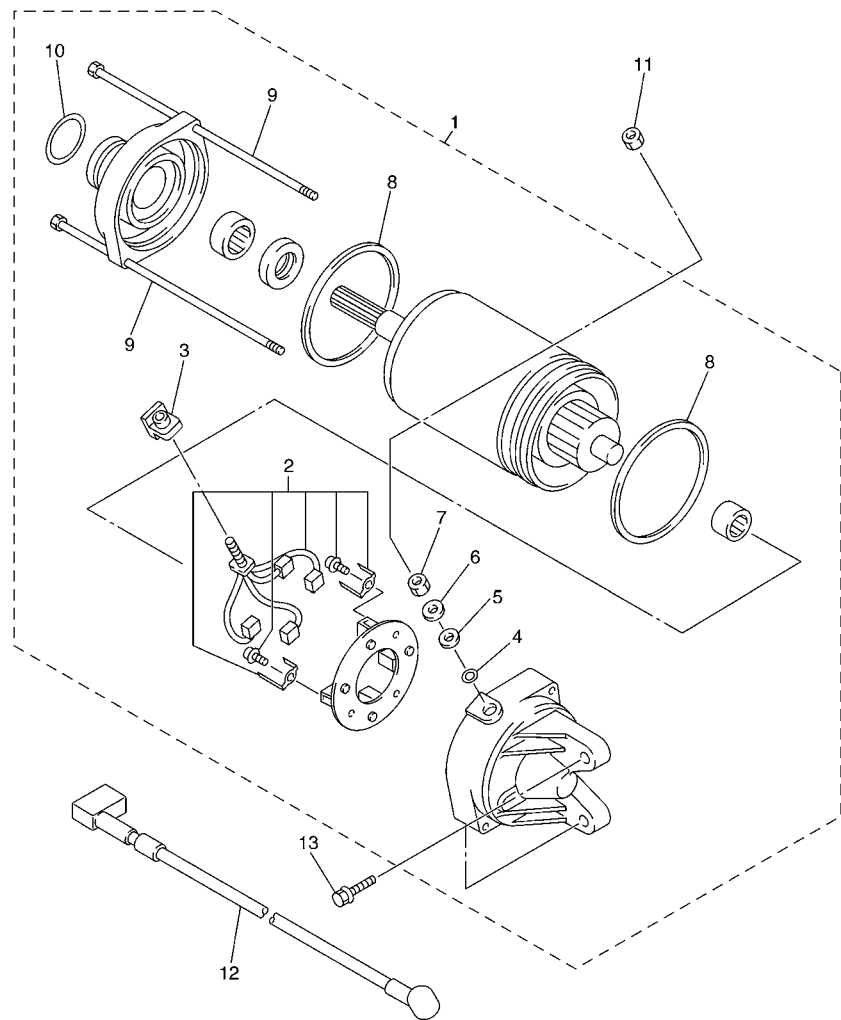

8GS3100-G400

FIG. 40 STARTING MOTOR

REF. NO.	PART NO.	DESCRIPTION	QTY	QTY	REMARKS
1	8GL-81890-00	MOTOR ASSY	1	1	
2	2S3-81801-00	.BRUSH SET	1	1	
3	2S3-8182G-00	.BUSH, TERMINAL	1	1	
4	93210-06001	.O-RING	1	1	
5	8FA-8181L-00	.WASHER, PLAIN	1	1	
6	1D7-81835-00	.WASHER	1	1	
7	95302-06700	.NUT	1	1	
8	5PX-81861-00	.GASKET	2	2	
9	8ES-81846-01	.SCREW	2	2	
10	93210-24235	.O-RING	1	1	
11	95302-06700	NUT	1	1	
12	8ES-8183G-00	CORD COMP.	1	1	
13	95812-08030	BOLT, FLANGE	2	2	

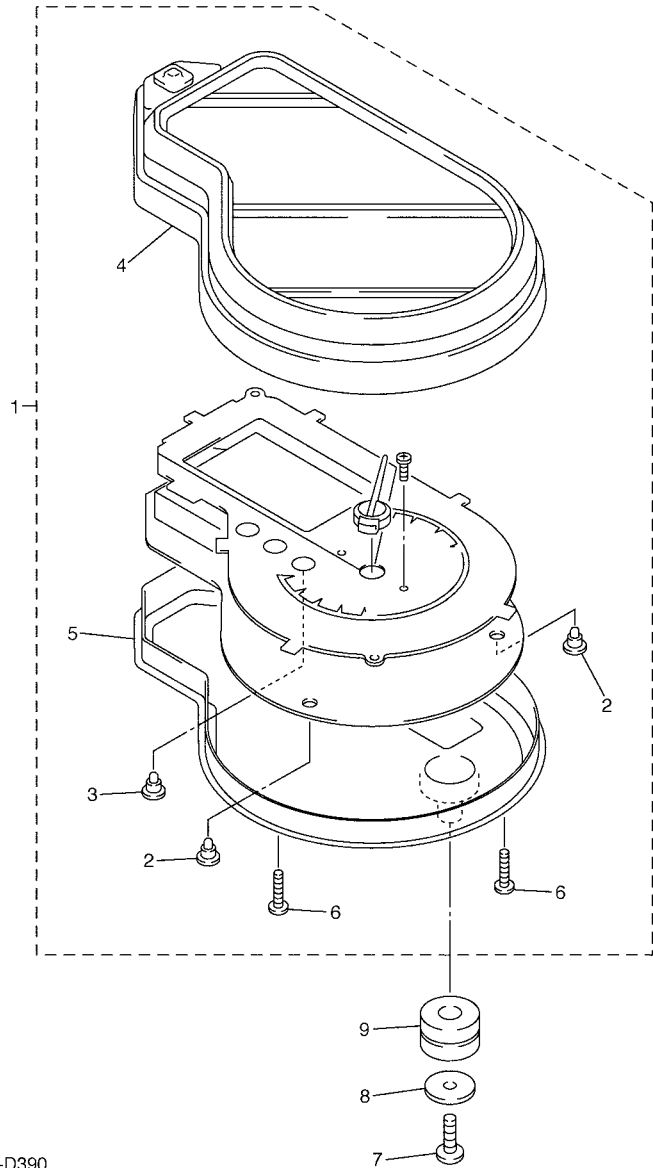

8ES1100-D390

FIG. 41 METER

REF. NO.	PART NO.	DESCRIPTION	8JE2	8JE1			REMARKS
1	8JE-83500-00	METER ASSY (KM/H)	1	1			
2	4WM-83517-00	.BULB (T3 14V-50MA)	6	6			
3	4WM-83517-10	.BULB (T3.4 14V-80MA)	3	3			
4	8EK-8353E-01	.CASE, METER UPPER	1	1			
5	8EK-83572-01	.CASE, SPEEDOMETER LOWER	1	1			
6	5PW-8352S-00	.SCREW, PANEL FITTING	7	7			
7	97702-50016	SCREW, TAPPING	3	3			
8	90201-05725	WASHER, PLATE	3	3			
9	4XV-83513-00	DAMPER	3	3			

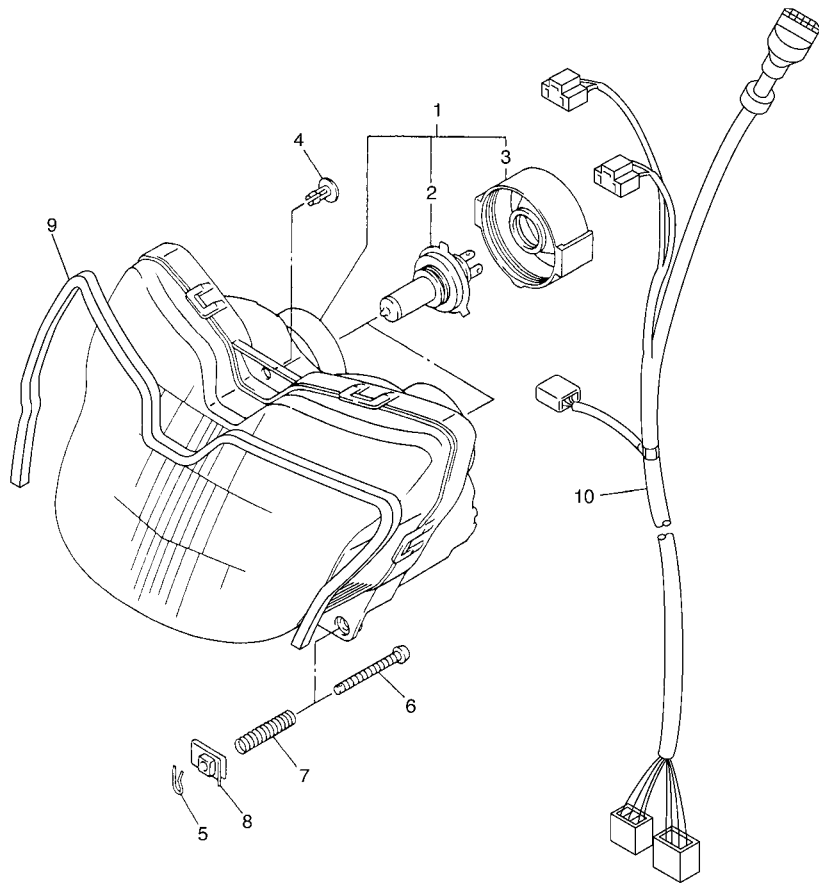

8FN1100-E410

FIG. 42 HEADLIGHT

REF. NO.	PART NO.	DESCRIPTION	8J/2	8J/1		REMARKS
1	8DN-84310-01	HEADLIGHT UNIT ASSY	1	1		
2	8G9-84314-00	.BULB (12V-60/55W)	2	2		(H4)HALOGEN
3	8DN-84397-01	.COVER, SOCKET	2	2		
4	90269-06046	RIVET	1	1		
5	8K4-84374-00	CLIP	2	2		
6	8A5-84331-00	SCREW, RIM ADJUSTING	2	2		
7	8A5-84332-00	SPRING, SCREW	2	2		
8	90183-05024	NUT, SPRING	2	2		
9	8FN-8399N-00	INSULATOR 1	1	1		
10	8FN-84359-00	CORD, HEADLIGHT	1	1		

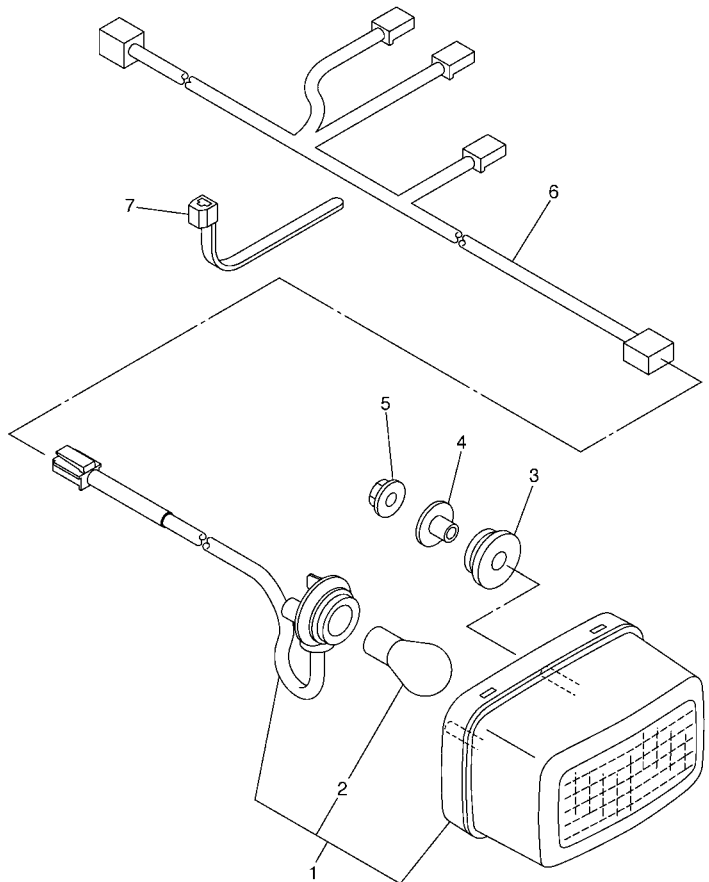
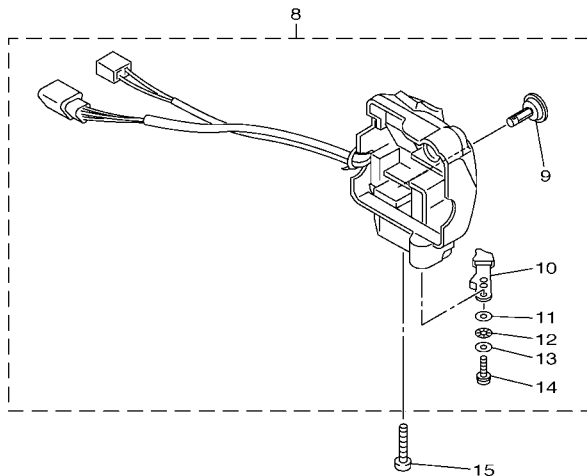
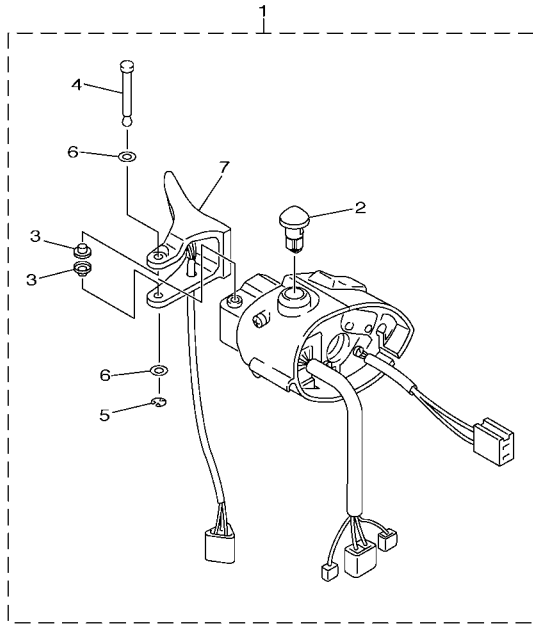

FIG. 43 TAILLIGHT

REF. NO.	PART NO.	DESCRIPTION	8/JE2	8/JE1			REMARKS
1	8FN-84710-00	TAILLIGHT UNIT ASSY	1	1			
2	1A2-84714-41	.BULB (12V-21/5W)	1	1			
3	90480-18007	GROMMET	2	2			
4	90387-06033	COLLAR	2	2			
5	95702-06500	NUT, FLANGE	2	2			
6	8FN-84717-00	CORD, TAILLIGHT	1	1			
7	90464-25004	CLAMP	2	2			

8FN1100-E420



8JE2110-M440

FIG. 44 HANDLE SWITCH & LEVER

REF. NO.	PART NO.	DESCRIPTION	8JE2	8JE1	REMARKS
1	8ES-82720-02	LEVER HOLDER ASSY (RIGHT)	1	1	
2	8GL-86284-09	.STOP SWITCH	1	1	
3	85G-83956-00	.CAP 1	2	2	
4	8R6-8399F-00	.SHAFT	1	1	
5	99001-04600	.CIRCLIP	1	1	
6	8FP-82558-00	.WASHER	2	2	
7	8FA-82970-01	.THUMB WARMER ASSY	1	1	
8	8FA-83973-01	SWITCH, HANDLE 3	1	1	
9	8GL-82526-09	.SWITCH, LAMP	1	1	
10	5GH-83941-00	.LEVER, STARTER	1	1	
11	8FA-83943-00	.WASHER, STARTER	1	1	
12	3L4-83943-00	.WASHER, STARTER	1	1	
13	1UY-83909-00	.WASHER, SPECIAL	1	1	
14	97607-05112	.SCREW,WITH WASHER	1	1	
15	98502-05016	SCREW, PAN HEAD	2	2	

FIG. 45 ELECTRICAL 1

REF. NO.	PART NO.	DESCRIPTION	8J/E2	8J/E1		REMARKS
1	8JE-82305-00	IGNITOR UNIT ASSY	1	1		
2	8ES-85991-00	BRACKET, UNIT	1	1		
3	95822-06016	BOLT, FLANGE	2	2		
4	95822-06010	BOLT, FLANGE	2	2		
5	8ES-82310-00	IGNITION COIL ASSY	3	3		
6	5JW-81960-00	RECTIFIER & REGULATOR ASSY	1	1		
7	90105-06185	BOLT, FLANGE	2	2		
8	8JE-82590-00	WIRE HARNESS ASSY	1	1		
9	5JJ-82151-20	.FUSE (20A-BL)	3	3		
10	5JJ-82151-30	.FUSE (10A-BL)	2	2		
11	5JJ-82151-10	.FUSE (15A-BL)	3	3		
12	5JJ-82151-50	.FUSE (3A-BL)	2	2		
13	90464-15195	CLAMP	6	6		
14	90464-13073	CLAMP	4	4		
15	90464-12045	CLAMP	1	1		
16	90464-13077	CLAMP	3	3		
17	90464-35132	CLAMP	1	1		
18	5DM-81950-00	RELAY ASSY (G8HN-1C4T-DJ-Y52)	2	2		
19	8DM-81950-11	RELAY ASSY	4	4		
20	8HV-82510-00	MAIN SWITCH ASSY	1	1		
21	8GK-83755-11	SENSOR, SPEED	1	1		
22	95702-08300	NUT, NYLON	4	4		
23	8EK-47551-00	HOUSING, FRONT AXLE	1	1		
24	8GL-83383-00	BUZZER	1	1		
25	90159-05035	SCREW, WITH WASHER	1	1		
26	95702-05500	NUT, FLANGE	1	1		

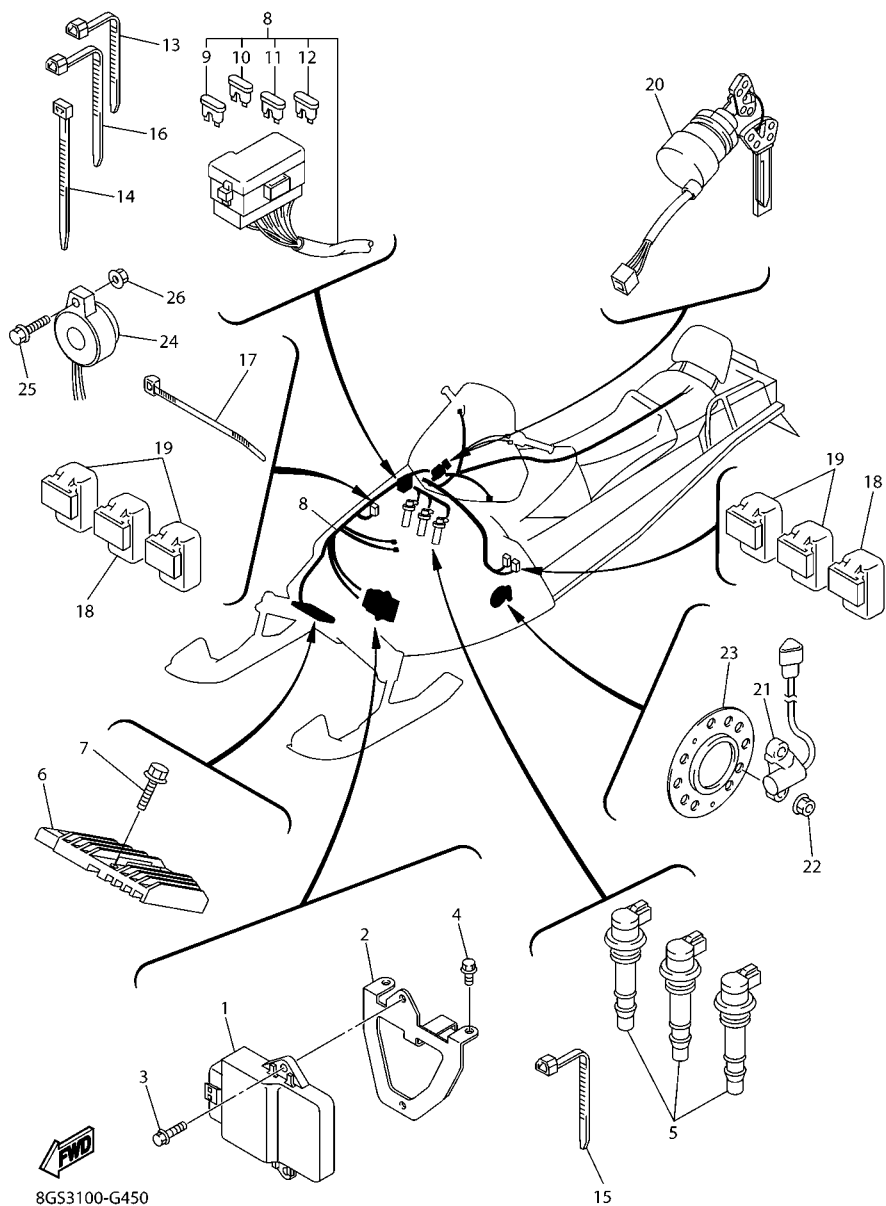

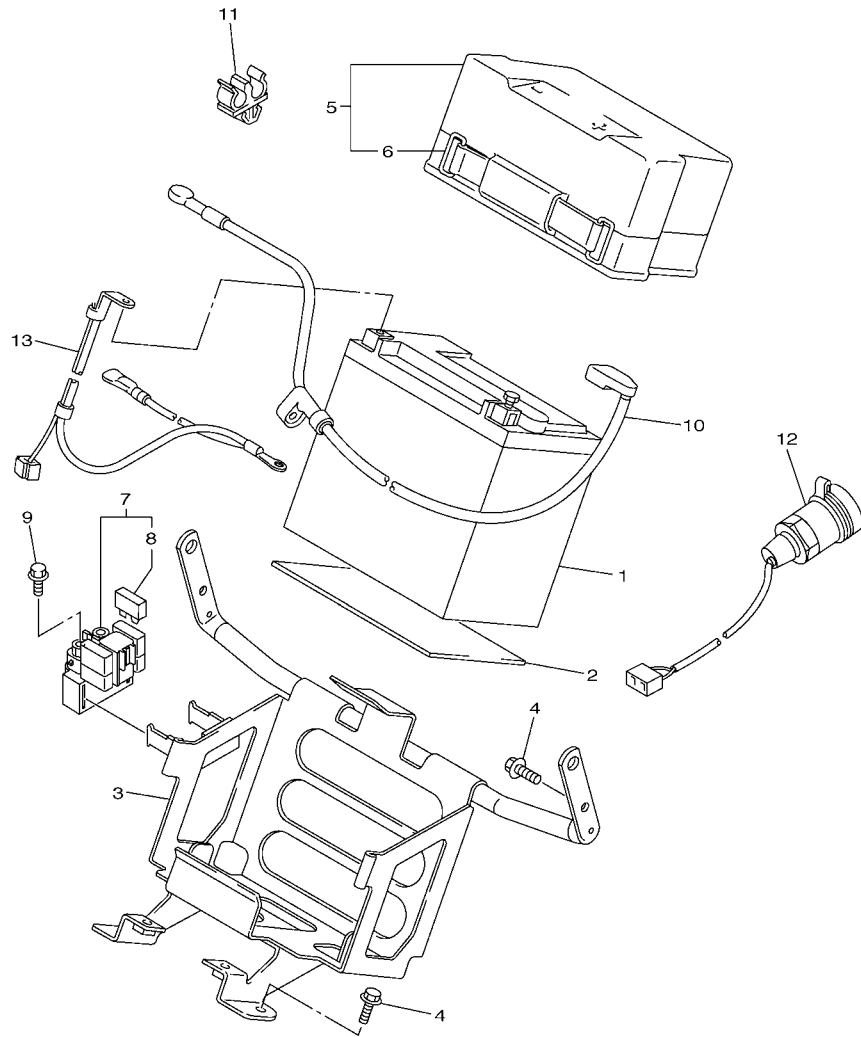

8JE2110-M460

FIG. 46 ELECTRICAL 2

REF. NO.	PART NO.	DESCRIPTION	8JE2	8JE1	REMARKS
1	4SH-82100-22	BATTERY ASSY (YUASA YTX20L-BS)	1	1	UR FOR EUR,RUS
	90793-26123	BATTERY ASSY (YTX20L-BS-GY)		1	UR FOR JPN
2	8FA-82122-00	SEAT, BATTERY	1	1	
3	8FN-2199G-00	BRACKET, BATTERY	1	1	
4	95822-08016	BOLT, FLANGE	4	4	
5	8FA-82129-00	COVER, BATTERY	1	1	
6	8DM-82131-10	.BAND, BATTERY	1	1	
7	3D7-81940-00	STARTER RELAY ASSY	1	1	
8	1AE-82151-00	.FUSE (30A-BL)	2	2	
9	95022-06008	BOLT, FLANGE	2	2	
10	8FN-82115-00	WIRE, PLUS LEAD	1	1	
11	90464-08126	CLAMP	1	1	
12	8FP-8254B-00	TERMINAL COMP.	1	1	
13	8FN-82116-00	WIRE, MINUS LEAD	1	1	

FIG. 47 ELECTRICAL 3

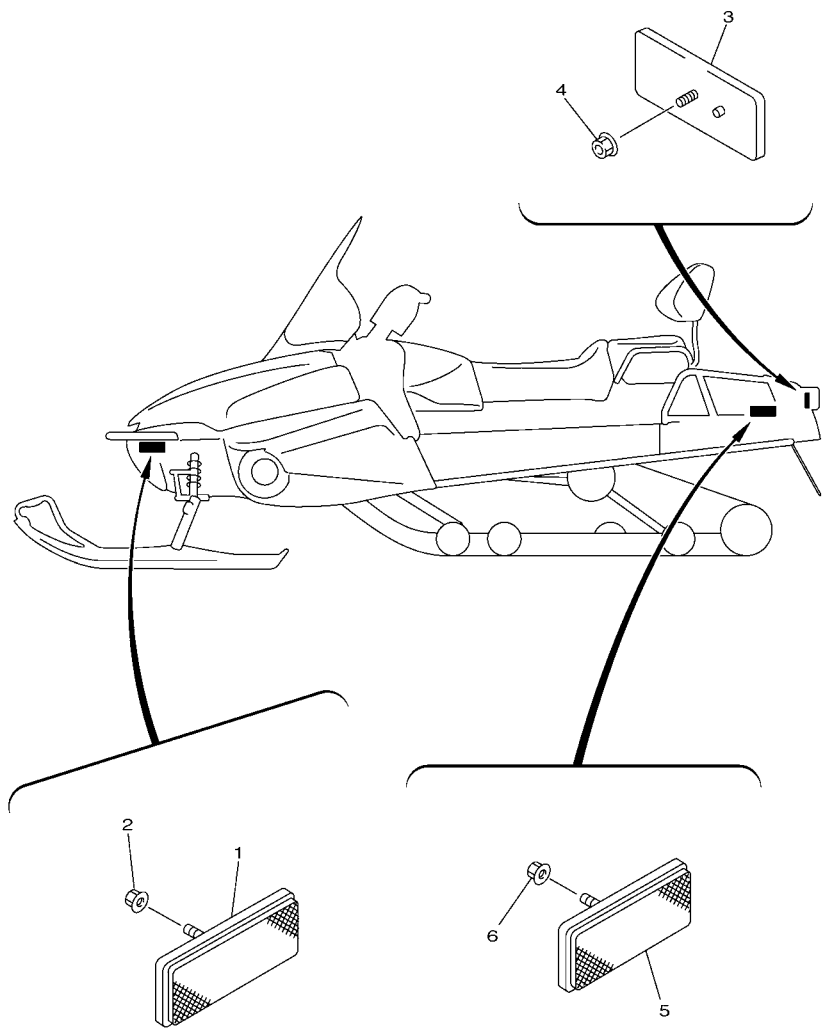

8JE2110-M470

REF. NO.	PART NO.	DESCRIPTION	8JE2	8JE1	REMARKS
1	8GM-85110-00	REFLECTOR ASSY	2	2	
2	95702-05500	NUT, FLANGE	2	2	
3	3Y6-85130-02	REAR REFLECTOR ASSY	2	2	
4	95707-05500	NUT, FLANGE	2	2	
5	3Y6-85130-02	REAR REFLECTOR ASSY	2		
6	95707-05500	NUT, FLANGE	2	2	

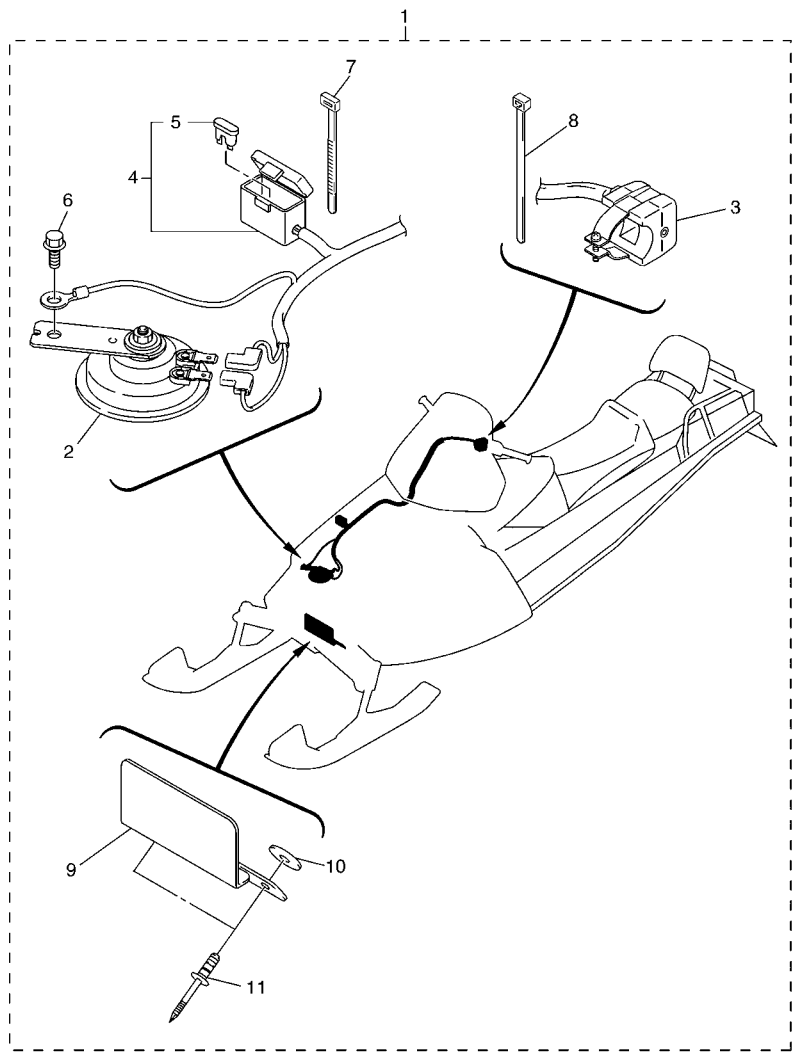

FWD
 8GS3100-G480

FIG. 48 ELECTRICAL 4

REF. NO.	PART NO.	DESCRIPTION	8JE2	8JE1	REMARKS
1	8JE-833A0-00	HORN KIT		1	FOR FINLAND
2	3MX-83371-11	.HORN		1	FOR FINLAND
3	8FR-83976-02	.SWITCH, HANDLE 1		1	FOR FINLAND
4	8JE-82509-00	.WIRE, SUB LEAD		1	FOR FINLAND
5	5JJ-82151-50	.FUSE (3A-BL)		1	FOR FINLAND
6	95822-06016	.BOLT, FLANGE		1	FOR FINLAND
7	437-83936-01	.BAND, SWITCH CORD		2	FOR FINLAND
8	90465-13152	.CLAMP		1	FOR FINLAND
9	8GU-21641-00	.BRACKET, REFLECTOR		1	FOR FINLAND
10	90201-05036	.WASHER, PLATE		2	FOR FINLAND
11	90267-47186	.RIVET, BLIND (4.7X16.4 BLACK)		2	FOR FINLAND

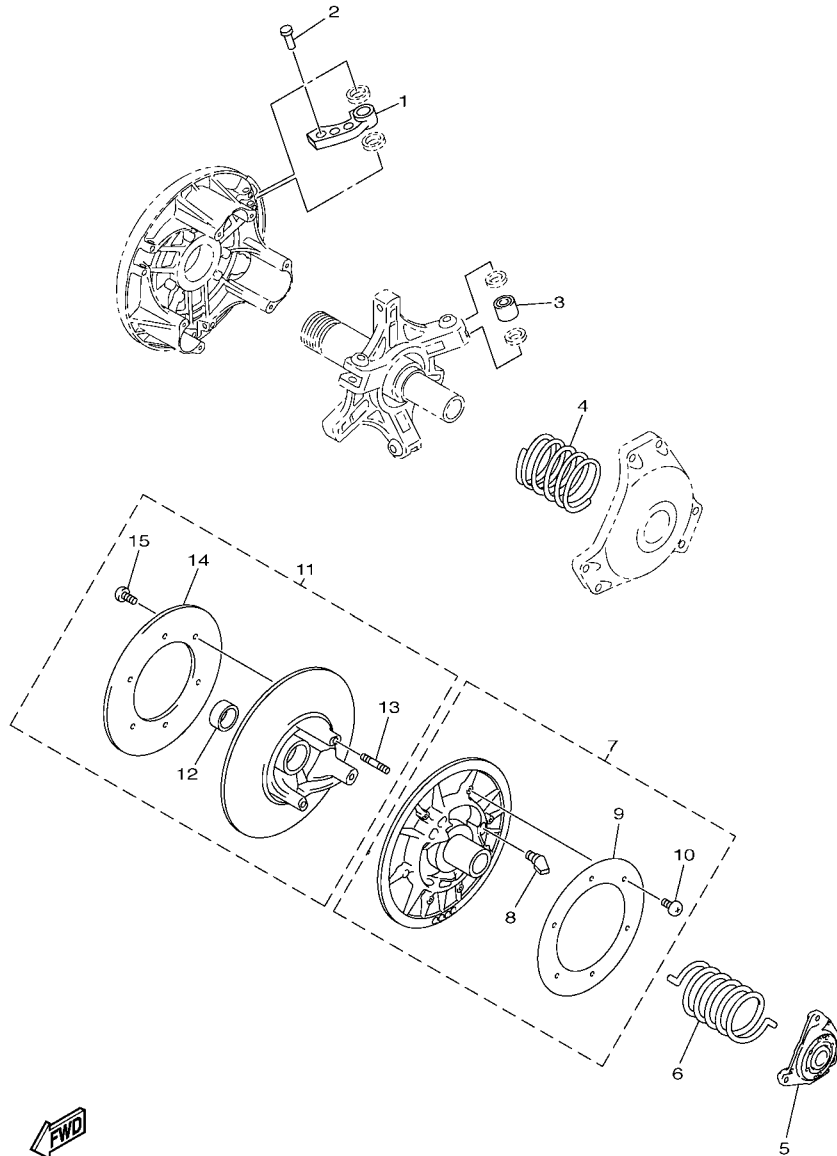

8HG1110-K490

FIG. 49 ALTERNATE DRIVE SETTING 1

REF. NO.	PART NO.	DESCRIPTION	B/EZ	B/EI		REMARKS
1	8DN-17605-30	WEIGHT COMP	3	3		UR
	8ES-17605-00	WEIGHT COMP	3	3		UR
	8FN-17605-00	WEIGHT COMP	3	3		UR
	8FP-17605-00	WEIGHT COMP	3	3		UR
	8FS-17605-00	WEIGHT COMP	3	3		UR
	8GC-17605-00	WEIGHT COMP	3	3		UR
	8GL-17605-00	WEIGHT COMP	3	3		UR
	8HF-17605-00	WEIGHT COMP	3	3		UR
	8HG-17605-00	WEIGHT COMP	3	3		UR
2	90261-06028	RIVET, COUNTERSUNK (AL10.3MM)	3	3		UR
	90266-06001	RIVET (AL13.3)	3	3		UR
	90261-06015	RIVET, COUNTERSUNK (ST10.3MM)	3	3		UR
	90266-06002	RIVET (ST13.3)	3	3		UR
	90261-06019	RIVET, COUNTERSUNK (ST13.3MM)	3	3		UR
	90261-06034	RIVET, COUNTERSUNK (ST13.9MM)	3	3		UR
	90269-06006	RIVET (ST17.2MM)	3	3		UR
	90261-06033	RIVET, COUNTERSUNK (ST17.2MM)	3	3		UR
3	8FG-17624-00	ROLLER, COMP	3	3		UR
	8FG-17624-10	ROLLER, COMP	3	3		UR
	8FG-17624-20	ROLLER, COMP	3	3		UR
	8FG-17624-30	ROLLER, COMP	3	3		UR
	8FG-17624-40	ROLLER, COMP	3	3		UR
4	90501-550A2	SPRING, COMPRESSION	1	1		UR (BL-BL-BL)
	90501-550A3	SPRING, COMPRESSION	1	1		UR (WH-BL-WH)
	90501-580A1	SPRING, COMPRESSION	1	1		UR (Y-BL-Y)
	90501-600A1	SPRING, COMPRESSION	1	1		UR (P-BL-P)
	90501-550A5	SPRING, COMPRESSION	1	1		UR (BL-Y-BL)

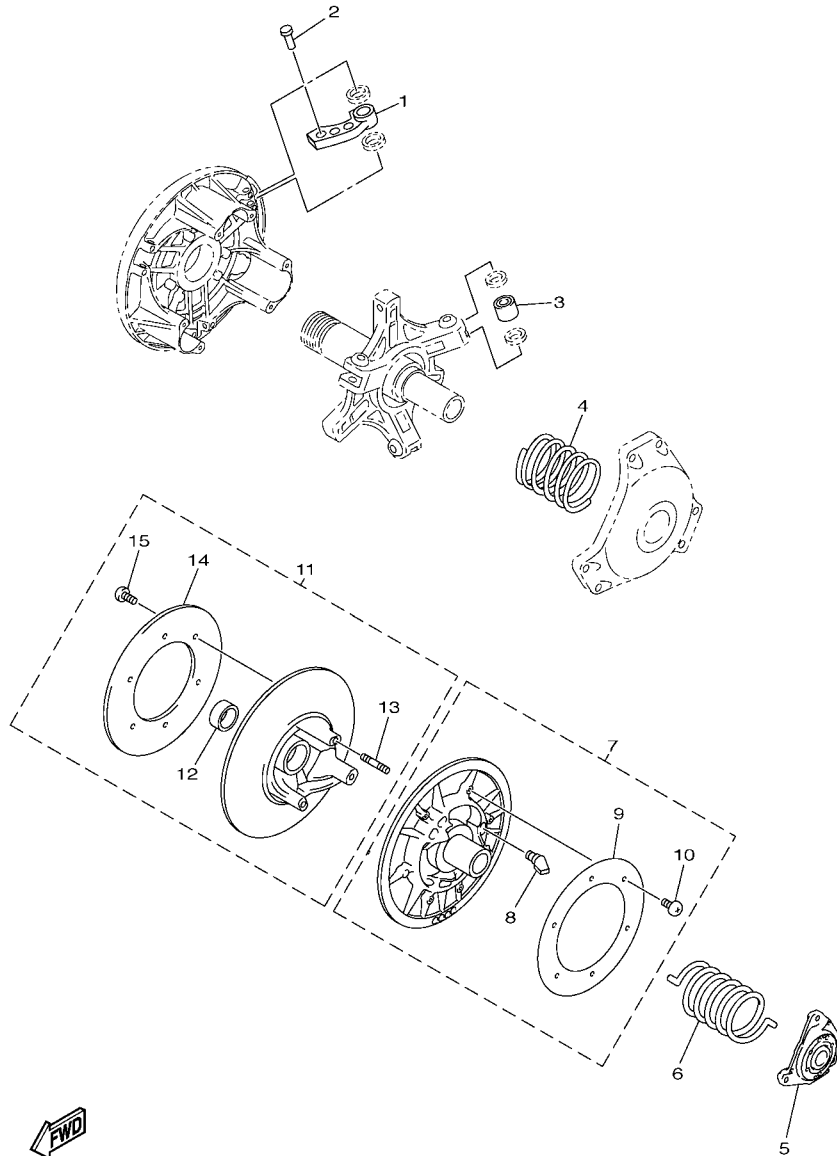

8HG1110-K490

FIG. 49 ALTERNATE DRIVE SETTING 1

REF. NO.	PART NO.	DESCRIPTION	8/E2	8/E1		REMARKS
4	90501-550A6	SPRING, COMPRESSION	1	1		UR (WH-Y-WH)
	90501-580A3	SPRING, COMPRESSION	1	1		UR (Y-Y-Y)
	90501-580A4	SPRING, COMPRESSION	1	1		UR (GR-Y-GR)
	90501-600A4	SPRING, COMPRESSION	1	1		UR (P-Y-P)
	90501-600A5	SPRING, COMPRESSION	1	1		UR (OR-Y-OR)
	90501-551L3	SPRING, COMPRESSION	1	1		UR (BL-P-BL)
	90501-583L5	SPRING, COMPRESSION	1	1		UR (WH-P-WH)
	90501-581L5	SPRING, COMPRESSION	1	1		UR (Y-P-Y)
	90501-581L6	SPRING, COMPRESSION	1	1		UR (GR-P-GR)
	90501-601L7	SPRING, COMPRESSION	1	1		UR (P-P-P)
	90501-601L8	SPRING, COMPRESSION	1	1		UR (OR-P-OR)
	90501-551L9	SPRING, COMPRESSION	1	1		UR (BL-SL-BL)
	90501-583L4	SPRING, COMPRESSION	1	1		UR (WH-SL-WH)
	90501-582L1	SPRING, COMPRESSION	1	1		UR (Y-SL-Y)
	90501-582L2	SPRING, COMPRESSION	1	1		UR (GR-SL-GR)
	90501-602L3	SPRING, COMPRESSION	1	1		UR (P-SL-P)
	90501-624L8	SPRING, COMPRESSION	1	1		UR (OR-SL-OR)
	90501-552L5	SPRING, COMPRESSION	1	1		UR (BL-GR-BL)
	90501-582L6	SPRING, COMPRESSION	1	1		UR (WH-GR-WH)
	90501-582L7	SPRING, COMPRESSION	1	1		UR (Y-GR-Y)
	90501-602L8	SPRING, COMPRESSION	1	1		UR (GR-GR-GR)
	90501-602L9	SPRING, COMPRESSION	1	1		UR (P-GR-P)
	90501-583L0	SPRING, COMPRESSION	1	1		UR (BL-WH-BL)
	90501-583L1	SPRING, COMPRESSION	1	1		UR (WH-WH-WH)
	90501-603L2	SPRING, COMPRESSION	1	1		UR (Y-WH-Y)
	90501-603L3	SPRING, COMPRESSION	1	1		UR (GR-WH-GR)
	90501-580A2	SPRING, COMPRESSION	1	1		UR (BL-BR-BL)

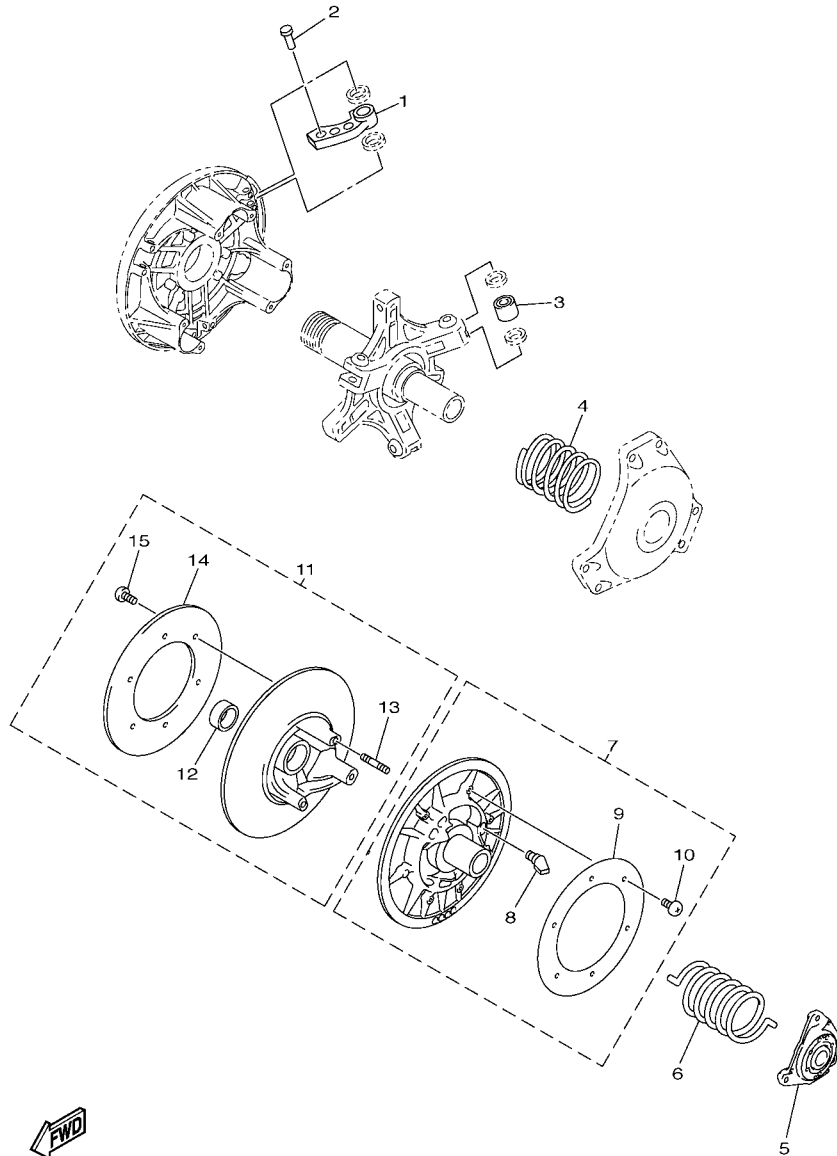

8HG1110-K490

FIG. 49 ALTERNATE DRIVE SETTING 1

REF. NO.	PART NO.	DESCRIPTION	8/E2	8/E1		REMARKS
5	8BV-17604-11	SEAT SPRING SET	1	1		UR
	8BV-17604-31	SEAT SPRING SET	1	1		UR
	8BV-17604-51	SEAT SPRING SET	1	1		UR
	8BV-17604-71	SEAT SPRING SET	1	1		UR
	8BV-17604-91	SEAT SPRING SET	1	1		UR
	8FA-17604-00	SEAT SPRING SET	1	1		UR
6	90508-536A9	SPRING, TORSION	1	1		UR (RED)
	90508-556A2	SPRING, TORSION	1	1		UR (GREEN)
	90508-556A7	SPRING, TORSION	1	1		UR (SILVER)
	90508-500B1	SPRING, TORSION	1	1		UR (BROWN)
	90508-60007	SPRING, TORSION	1	1		UR (WHITE)
	90508-60016	SPRING, TORSION	1	1		UR (WH-WH)
	90508-60012	SPRING, TORSION	1	1		UR (PINK)
	90508-60018	SPRING, TORSION	1	1		UR (P-P)
7	8CR-17660-10	SECONDARY FIXED SHEAVE COMP.	1	1		UR
8	8AV-17688-10	.SHOE, RAMP	3	3		UR
9	8CM-17665-00	.PLATE 1	1	1		UR
10	90150-05040	.SCREW, ROUND HEAD	6	6		UR
11	8BU-17670-10	SECONDARY SLIDING SHEAVE	1	1		UR
12	90384-38243	.BUSH, BIMETAL FORMED	1	1		UR
13	95617-08630	.BOLT, STUD	3	3		UR
14	8CM-17675-00	.PLATE 2	1	1		UR
15	90150-05040	.SCREW, ROUND HEAD	6	6		UR

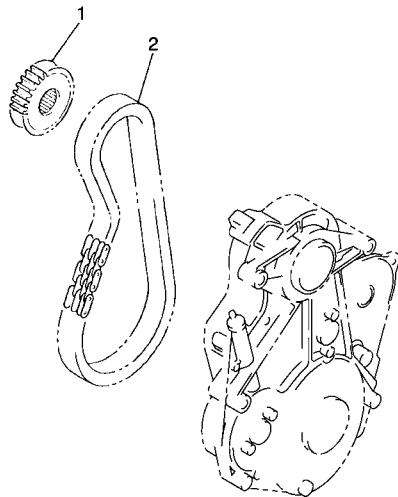

8GS1100-F490

FIG. 50 ALTERNATE DRIVE SETTING 2

REF. NO.	PART NO.	DESCRIPTION	8JE2	8JE1			REMARKS
1	8FA-17682-80	SPROCKET, CHAIN DRIVE (18T)	1	1			UR
	8FA-17682-90	SPROCKET, CHAIN DRIVE (19T)	1	1			UR
	8FA-17682-00	SPROCKET, CHAIN DRIVE (20T)	1	1			UR
	8FA-17682-10	SPROCKET, CHAIN DRIVE (21T)	1	1			UR
	8FA-17682-20	SPROCKET, CHAIN DRIVE (22T)	1	1			UR
	8FA-17682-30	SPROCKET, CHAIN DRIVE (23T)	1	1			UR
	8FA-17682-40	SPROCKET, CHAIN DRIVE (24T)	1	1			UR
2	94890-09068	CHAIN (68L)	1	1			UR
	94890-09070	CHAIN (70L)	1	1			UR

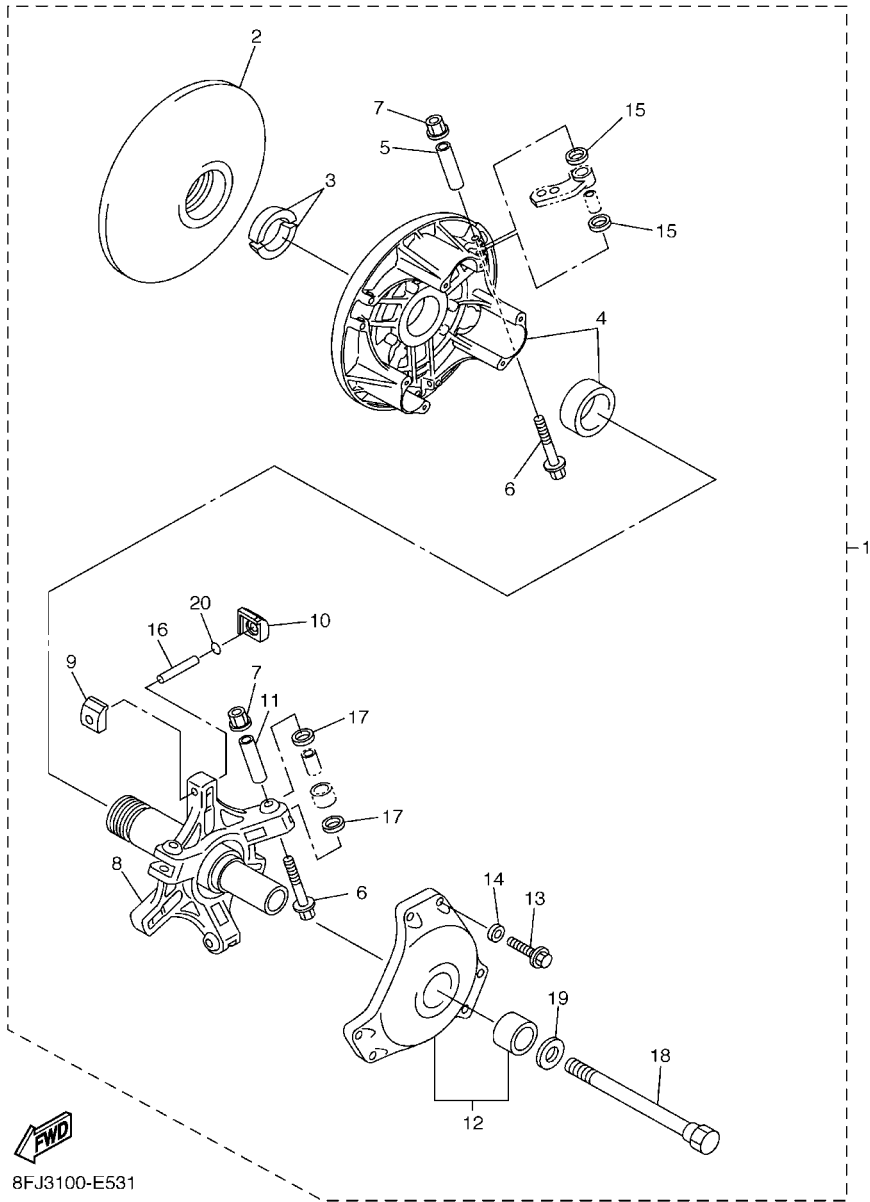
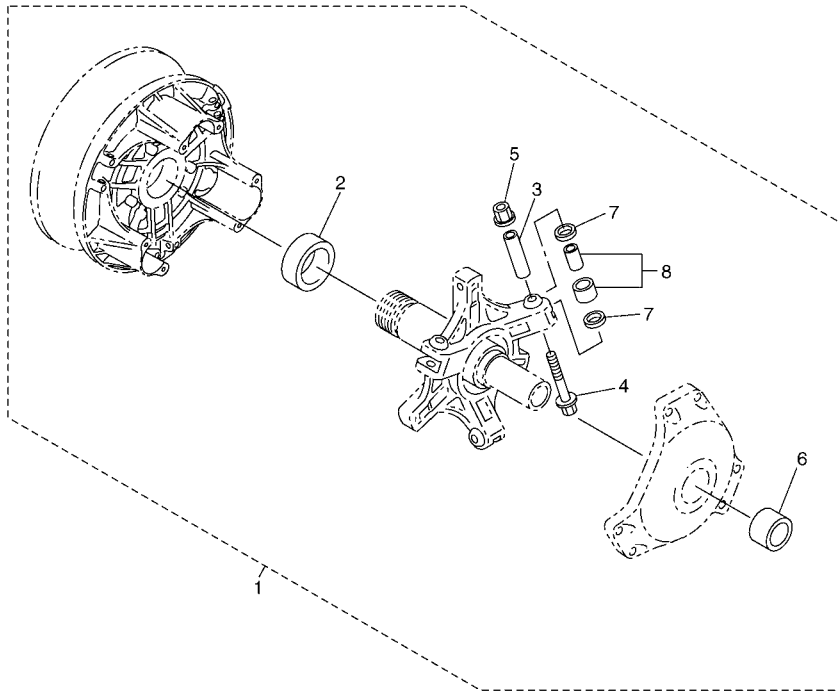

FIG. 51 ALTERNATE REBUILD KIT

REF. NO.	PART NO.	DESCRIPTION	8/E2	8/E1	REMARKS
1	8ES-W176G-12	CLUTCH REPAIR KIT	1	1	AP
2	8FA-17611-01	.SHEAVE, PRIMARY FIXED	1	1	
3	8V0-17639-00	.STOPPER	2	2	
4	8FP-17620-00	.PRIMARY SLIDING SHEAVE COMP.	1	1	
5	90387-0514T	.COLLAR	3	3	
6	90105-05644	.BOLT, FLANGE	6	6	
7	95607-05200	.NUT, U FLANGE	6	6	
8	8ES-17640-02	.SPIDER COMPLETE	1	1	
9	8BW-17653-00	.SLIDER	3	3	
10	8ES-17653-00	.SLIDER	3	3	
11	90387-0514U	.COLLAR	3	3	
12	8DF-17630-00	.PRIMARY SHEAVE CAP COMP.	1	1	
13	97017-06030	.BOLT	6	6	
14	92907-06600	.WASHER, PLATE	6	6	
15	90202-08204	.WASHER, PLATE	6	6	
16	91609-50032	.PIN, SPRING	3	3	
17	90202-09227	.WASHER, PLATE	6	6	
18	8V0-17647-00	.BOLT (L=156.5MM)	1	1	
19	92907-16100	.WASHER	1	1	
20	8ES-17655-00	.DAMPER, SLIDER	3	3	

FIG. 52 ALTERNATE CLUTCH TUNE UP KIT



REF. NO.	PART NO.	DESCRIPTION	QTY	QTY		REMARKS
1	8FA-W176H-10	CLUTCH TUNE-UP KIT	1	1		AP
2	90384-41242	.BUSH, BIMETAL FORMED	1	1		
3	90387-0514U	.COLLAR	3	3		
4	90105-05644	.BOLT, FLANGE	3	3		
5	95607-05200	.NUT, U FLANGE	3	3		
6	90380-28237	.BUSH, SOLID	1	1		
7	90202-09227	.WASHER, PLATE	6	6		
8	8FG-17624-20	.ROLLER, COMP	3	3		



8FA1100-B550

NUMERICAL INDEX

PART NO.	REF. NO.	PART NO.	REF. NO.	PART NO.	REF. NO.	PART NO.	REF. NO.	PART NO.	REF. NO.	PART NO.	REF. NO.
8ES-11101-02	1 - 1	3LD-12168-A0	3 - 8	8FN-1244J-00	6 - 74	4JH-14121-00	10 - 27	8FA-14623-10	11 - 4	8GL-15590-00	14 - 4
4KG-1111G-00	1 - 17	3LD-12168-F0	3 - 8	8ES-12450-01	5 - 7	8ES-14121-00	10 - 51	8ES-14627-00	11 - 7	8ES-16775-00	2 - 18
5JW-11133-10	1 - 2	3LD-12168-H1	3 - 8	8ES-12459-01	5 - 9	4YR-14133-00	10 - 38	8FN-14637-00	11 - 9	8JE-17110-00	31 - 83
3P6-11134-10	1 - 3	3LD-12168-K1	3 - 8	8FN-12460-00	6 - 42	8ES-14146-00	22 - 14	8JE-14708-00	11 - 23	8JE-1714A-00	31 - 68
8ES-11181-00	1 - 18	3LD-12168-M1	3 - 8	8ES-12461-00	6 - 73	8ES-14147-00	10 - 6	8ES-14714-10	11 - 16	8GS-17210-00	31 - 81
8ES-11191-01	1 - 11	3LD-12168-R1	3 - 8	3XP-12462-00	6 - 47	8ES-14148-00	9 - 29	8FA-14715-00	11 - 3	8JE-17243-00	31 - 76
8ES-11193-00	1 - 13	3LD-12168-U1	3 - 8	8FN-12464-00	6 - 88	8ES-1414G-00	10 - 16	8FA-14737-00	11 - 20	8CW-17492-00	31 - 77
8ES-11400-02	2 - 1	3LD-12168-W1	3 - 8	8FN-12467-00	6 - 57	8ES-14162-00	10 - 33	8FA-17604-00	11 - 19	8FA-17604-00	49 - 5
8ES-11406-02	2 - 16	3LD-12168-Y1	3 - 8	8FN-12469-00	6 - 77	8ES-1417E-00	36 - 12	8FA-14788-00	11 - 17	8BV-17604-11	49 - 5
8ES-11407-02	2 - 22	3LD-12169-11	3 - 8	8FN-12477-02	6 - 62	3TJ-14191-40	10 - 22	8ES-1478N-00	11 - 26	8BV-17604-31	49 - 5
3LD-11416-10	2 - 6	3LD-12169-31	3 - 8	8ES-12482-00	6 - 1	8ES-14197-01	10 - 43	8ES-14900-02	10 - 1	8BV-17604-51	49 - 5
3LD-11416-20	2 - 6	3LD-12169-50	3 - 8	8ES-12485-01	6 - 2	4JH-14216-00	10 - 10	8ES-14901-01	10 - 2	8BV-17604-71	49 - 5
3LD-11416-30	2 - 6	3LD-12169-70	3 - 8	4TV-12486-00	10 - 50		10 - 10	8ES-14902-01	10 - 3	8BV-17604-91	16 - 11
3LD-11416-40	2 - 6	3LD-12169-90	3 - 8	8FN-1248A-00	6 - 65	4YR-14216-00	10 - 47	8ES-14903-01	10 - 4		49 - 5
3LD-11416-50	2 - 6	3LD-12169-E0	3 - 8	8FN-1248E-00	6 - 68	4JH-14264-00	10 - 31	8ES-14916-00	10 - 14	8ES-17605-00	49 - 1
3LD-11416-60	2 - 6	3LD-12169-G0	3 - 8	8FW-1249A-00	6 - 9	8ES-14283-00	9 - 26	4TV-14926-00	10 - 26	8FN-17605-00	15 - 25
3LD-11416-70	2 - 6	3LD-12169-J0	3 - 8	8FN-12577-00	6 - 4	8ES-14294-00	9 - 4	8ES-14926-01	10 - 24		49 - 1
8ES-11428-01	2 - 29	3LD-12169-L0	3 - 8	8ES-12578-00	6 - 17	8ES-14294-10	9 - 4	8ES-14933-00	10 - 11	8FP-17605-00	49 - 1
8ES-11454-00	2 - 25	3LD-12169-N0	3 - 8	8FN-12579-00	6 - 11	8ES-14295-00	10 - 40	4YR-14934-00	10 - 52	8FS-17605-00	49 - 1
59J-11455-00	2 - 15	3LD-12169-T0	3 - 8	8FN-12580-10	6 - 24	8ES-14298-00	9 - 6	8ES-14935-00	10 - 32	8GC-17605-00	49 - 1
8ES-11464-00	2 - 32	8ES-12170-01	4 - 1	8ES-12588-00	6 - 19	8ES-14298-10	9 - 6	4JH-14936-00	10 - 13	8GL-17605-00	49 - 1
8ES-11478-00	2 - 30	8ES-12176-00	4 - 2	8FN-12589-00	6 - 21	4JH-14358-00	10 - 34	3TJ-14937-40	10 - 44	8HF-17605-00	49 - 1
8ES-11530-00	2 - 23	8ES-12210-01	4 - 5	8FN-12590-00	6 - 46	8ES-14419-00	9 - 23	8ES-14940-00	10 - 12	8HG-17605-00	49 - 1
5JW-11603-00	2 - 8	4FM-12213-00	4 - 6	8ES-13115-00	7 - 15	8ES-1441A-00	9 - 22	3TJ-14943-36	10 - 17	8DN-17605-30	49 - 1
8ES-11631-00	2 - 7	5BE-12241-00	1 - 12	8FN-1319B-02	7 - 13	8ES-14425-00	9 - 20	3TJ-14943-37	10 - 17	8FA-17611-01	15 - 1
5JW-11633-00	2 - 10	8ES-12251-00	4 - 8	8ES-13284-00	7 - 5	8ES-14427-00	9 - 31	3TJ-14943-87	10 - 17		51 - 2
5JW-11650-01	2 - 2	8ES-12252-00	4 - 9	8ES-13300-00	7 - 1	8ES-14431-00	9 - 15	8ES-14947-00	10 - 15	8GS-1761A-00	31 - 15
5JW-11654-00	2 - 3	8FN-12405-01	6 - 43	4XV-13355-00	7 - 2	8FA-14436-00	9 - 19	8ES-14948-03	10 - 18	8JE-1761E-00	31 - 18
5JW-11656-00	2 - 5	8FP-12405-01	6 - 72	8FG-13406-00	18 - 2	8ES-14441-00	9 - 16	8ES-14948-05	10 - 18	8FP-17620-00	15 - 3
5JW-11656-10	2 - 5	8FN-12410-00	6 - 26	8ES-13414-01	8 - 4	8ES-14451-00	9 - 18	8ES-14948-06	10 - 18		51 - 4
5JW-11656-20	2 - 5	8EK-12412-00	6 - 27	8ES-13416-00	1 - 20	8ES-14452-00	9 - 21	8ES-14948-07	10 - 18	8FG-17624-00	49 - 3
5JW-11656-30	2 - 5	5EB-12413-00	6 - 25	8ES-13417-00	8 - 2	8ES-14453-00	9 - 24	8ES-14958-00	10 - 9	8FG-17624-10	49 - 3
5JW-11656-40	2 - 5	8ES-12420-02	5 - 1	8ES-13427-00	7 - 4	8ES-14454-00	10 - 48	8ES-14965-00	10 - 35	8FG-17624-20	15 - 22
5JW-11656-A0	2 - 5	8ES-12422-00	5 - 2	5DM-13440-00	8 - 1	8FN-14472-00	9 - 17	8ES-14984-00	10 - 21		49 - 3
5JW-12111-00	3 - 1	8ES-12427-00	5 - 3	8FN-13464-00	7 - 10	4JH-14487-00	10 - 39	8ES-14985-00	10 - 20		52 - 8
5JW-12113-00	3 - 4	8ES-12434-00	5 - 13	8ES-13470-01	8 - 9	4TV-14534-00	10 - 56	8ES-14987-00	10 - 49	8FG-17624-30	49 - 3
5JW-12116-00	3 - 3	8ES-12435-00	5 - 12	5JW-13473-00	8 - 10	676-14548-00	10 - 19	8ES-15100-08	12 - 1	8FG-17624-40	49 - 3
5JW-12117-00	3 - 5	8ES-12436-00	5 - 17	8FN-13520-00	18 - 13	7A9-14555-00	10 - 28	8FA-15113-00	39 - 4	8DF-17630-00	15 - 17
1AA-12118-00	3 - 6	8ES-12438-00	5 - 4	8ES-13586-10	9 - 1	4YR-14557-00	10 - 57	8ES-15167-00	12 - 3		51 - 12
5JW-12121-01	3 - 2	8FN-1243A-00	6 - 75	8ES-13815-00	10 - 41	8ES-14561-00	10 - 29	8ES-1531A-00	13 - 12	8V0-17639-00	15 - 2
3P6-12129-00	3 - 7	8FN-1243E-00	6 - 6	8ES-13816-00	10 - 42	4TV-14562-00	10 - 46	3Y1-15361-00	31 - 39		51 - 3
5EB-12153-09	3 - 9	8FN-1243F-00	6 - 76	8ES-13892-00	9 - 12	8ES-14565-00	10 - 30	3Y1-15363-10	1 - 14	8ES-17640-02	15 - 9
5EB-12153-10	3 - 9	8FN-12440-01	19 - 59	8ES-13895-00	9 - 10	8ES-14567-00	10 - 37	4JT-15381-01	2 - 26		51 - 8
3LD-12168-00	3 - 8	8FN-12443-00	9 - 37	8ES-13898-00	7 - 19	8ES-14578-00	10 - 36	8ES-15421-01	13 - 1	8GS-17641-00	15 - 30
3LD-12168-20	3 - 8	8FN-1244E-00	6 - 52	8FA-13910-00	9 - 32	8ES-14592-00	10 - 25	8ES-15461-01	13 - 6	8V0-17647-00	15 - 31
3LD-12168-40	3 - 8	8FN-1244F-00	6 - 87	8ES-146105-00	10 - 5	8ES-14610-00	11 - 13	8ES-15512-01	14 - 2		51 - 18
3LD-12168-60	3 - 8	8FN-1244G-00	6 - 40	8ES-14107-00	10 - 8	8ES-14613-00	11 - 2	8FA-15515-00	14 - 1	8BW-17653-00	15 - 10
3LD-12168-80	3 - 8	8FN-1244H-00	6 - 48	8ES-1410A-00	10 - 7	8ES-14615-01	11 - 1	8ES-15521-00	14 - 3		51 - 9

NUMERICAL INDEX

PART NO.	REF. NO.	PART NO.	REF. NO.	PART NO.	REF. NO.	PART NO.	REF. NO.	PART NO.	REF. NO.	PART NO.	REF. NO.
8ES-17653-00	15 - 11	8FG-21751-02	18 - 1	8FG-2197M-00	19 - 44	8CR-23847-00	21 - 30	8FN-2470H-10	24 - 5	8GS-2817S-J0	37 - 35
	51 - 10	89A-21815-00	6 - 33	8FN-2198E-00	19 - 15	8FA-23847-00	21 - 50	8FN-24710-10	24 - 1	8GJ-2842M-00	24 - 13
8ES-17655-00	15 - 13	8FN-21816-00	18 - 18	8FN-2198F-00	19 - 91	8FA-2384N-00	21 - 41	8FN-24723-00	36 - 24	8JD-47110-01	27 - 14
	51 - 20	8FN-21851-00	6 - 58	8FU-2198F-01	19 - 64	8FN-23851-00	20 - 24	8FN-24742-00	36 - 37	8HR-47113-09	27 - 15
8BV-17656-00	16 - 3	8FN-21871-00	6 - 32	8FU-2198G-00	19 - 46	8FN-23852-00	20 - 25	8FN-2474A-00	24 - 10	8HR-47115-09	27 - 16
8CR-17660-10	49 - 7	8FN-21912-00	33 - 26	8GS-2198H-00	33 - 28	8DF-23857-00	21 - 7	8GS-2474B-00	24 - 12	8AC-47310-10	28 - 47
8CR-17660-30	16 - 1	8FN-2191A-09	19 - 2	8FU-2198J-01	19 - 65	8FA-23867-00	21 - 23	8FN-2474H-00	24 - 16	8HF-47310-10	27 - 18
8CM-17665-00	49 - 9	8EK-21920-01	19 - 63	8FA-21999-00	19 - 52	8FN-23867-00	21 - 14	8FN-2474W-00	24 - 11		27 - 31
8BU-17670-10	49 - 11	8FN-21926-00	19 - 27	8FN-2199G-00	46 - 3	8GS-23870-01	22 - 1	8FN-24750-10	24 - 4		27 - 41
8BU-17670-30	16 - 5	8FN-21933-01	19 - 88	4AA-22259-40	28 - 21	8FA-23872-00	21 - 20	8FN-2476U-00	24 - 18	8HP-47310-10	27 - 50
8CM-17675-00	49 - 14	8FN-21936-00	19 - 28		28 - 36	8FN-23872-00	21 - 24	8FN-24772-00	36 - 27	8HF-47317-00	27 - 33
8GS-17681-02	16 - 14	8FN-21939-00	19 - 42	4AA-22259-50	28 - 21	8FA-23873-01	21 - 13	8FN-2478C-00	36 - 23		27 - 43
8FA-17682-00	31 - 54	8CR-21939-01	19 - 41		28 - 36	1UY-23894-01	21 - 26	8FN-2478E-00	36 - 33	8HP-47319-00	28 - 53
	50 - 1	8GS-2193A-01	19 - 12	4AA-22259-60	28 - 21	8FA-2389C-E0	22 - 6	8FN-24790-10	24 - 6	8ES-47319-01	27 - 17
8FA-17682-10	50 - 1	8FN-2193E-00	19 - 55		28 - 36	8FA-2389C-J0	22 - 6	3AC-24877-C0	24 - 9	8JD-47331-00	28 - 1
8FA-17682-20	50 - 1	8GS-21940-12	19 - 1	3YK-22472-40	20 - 28	8FA-2389C-S0	22 - 6	4KN-24877-C0	37 - 26	8JD-47332-00	28 - 54
8FA-17682-30	50 - 1	8JE-21943-00	19 - 29	8ED-23442-00	21 - 6	8FA-2389E-00	6 - 45	8FN-24897-00	24 - 9	8FM-47333-10	29 - 17
8FA-17682-40	50 - 1	8JE-21944-00	19 - 23	8ES-23501-10	20 - 12		22 - 10	8FM-24897-01	37 - 26	83R-47335-00	29 - 3
8FA-17682-80	50 - 1	8FN-21947-00	19 - 10	8ES-23502-10	20 - 17	8FN-2389K-00	21 - 35	8FN-24897-10	24 - 9	8FN-47336-20	28 - 22
8FA-17682-90	50 - 1	8FN-21949-00	19 - 77	8GS-23540-20	20 - 29	8FN-2389M-00	21 - 37	8FM-24897-11	37 - 26	83R-47337-10	29 - 1
8AV-17688-10	16 - 2	8FN-2194E-00	19 - 56	8GS-23550-20	20 - 32	8FN-24111-01	23 - 1	8FU-2580T-01	25 - 7	8GN-47338-00	27 - 26
	49 - 8	8FN-2194F-00	19 - 16	8GS-23570-20	20 - 42	8FN-24111-10	23 - 1	8FU-2581T-00	25 - 1	8AC-47341-00	27 - 11
8FB-17692-00	31 - 65	8FN-2194G-00	19 - 17	8GS-23580-20	20 - 45	8FN-24114-00	23 - 13	55U-25854-00	25 - 21	8HF-47341-00	28 - 5
8GS-18104-01	32 - 8	8FN-2194H-00	19 - 26	8JE-23711-00	20 - 1	8FA-2412G-00	21 - 42	8FA-25867-00	25 - 28	8JD-47349-00	28 - 27
8GS-18115-00	31 - 25	8FN-2194N-01	36 - 30	8JD-23731-00	20 - 3	8HF-2412G-00	21 - 27	8GS-25872-01	25 - 14	8JD-47349-10	28 - 49
8GS-18128-01	32 - 19	8FN-2194R-01	36 - 32	8HR-23738-00	20 - 4	8AC-2414B-01	34 - 5	8CR-2589F-00	25 - 23	8JD-47365-00	27 - 22
8GS-18152-01	32 - 10	8JE-21950-00	19 - 20	8ES-23743-00	20 - 11	8FN-2414E-00	36 - 29	8FN-25919-00	25 - 11	8AC-47366-00	28 - 45
2H9-18154-00	31 - 24	8FN-21953-00	19 - 36	8HR-23754-00	20 - 2	8FN-2414G-00	36 - 16	8FU-25924-00	25 - 12	8FN-47377-00	30 - 7
3X3-18157-10	31 - 28	8JE-21953-00	19 - 30	83R-23768-00	29 - 2	8FN-24181-00	22 - 4	8FU-25970-01	25 - 32	8HP-47384-00	27 - 46
8GS-18161-01	32 - 5	8JE-21954-00	19 - 24	8JE-2376A-00	20 - 57	8GS-24181-00	23 - 22	8FN-26110-10	21 - 1	8FK-47416-01	28 - 31
8GS-18164-00	32 - 1	8FN-21959-00	19 - 78	8FN-2376H-00	21 - 21	8FN-24182-00	22 - 5	8DM-26240-02	26 - 4	8JD-47417-00	28 - 69
8GS-18174-00	32 - 17	8FU-2195E-01	19 - 66	8HR-23778-00	20 - 5	8GS-24182-00	23 - 23	4SV-26280-00	33 - 43	8ES-47419-00	27 - 30
8GS-18179-01	32 - 23	8FU-2195F-01	19 - 67	8ES-23803-00	20 - 22	8FN-2418A-01	23 - 20	4SV-26290-00	33 - 44	8ES-47419-10	27 - 38
8GS-18191-00	31 - 23	8FN-21960-01	19 - 53	8FA-23811-00	21 - 11	8FN-241A3-00	36 - 20	8FN-26311-00	26 - 1	8JE-4741A-00	27 - 1
8GS-18511-00	31 - 85	8FN-21962-01	19 - 31	8FA-23812-00	21 - 22		36 - 36	8FN-26330-00	26 - 2	8DM-4741B-00	29 - 26
8GS-18531-00	31 - 86	8FN-21963-01	19 - 32	8FA-23813-01	21 - 4	8FN-241A4-00	36 - 21	8FN-26351-10	25 - 38	8JE-47421-00	27 - 2
8GS-18541-01	31 - 22	8GS-21965-10	19 - 34	8K1-23814-00	21 - 5	8FN-241A5-00	19 - 93	4N0-27114-00	38 - 3	8GL-47422-00	27 - 4
8FA-2139X-00	12 - 5	8GS-21966-10	19 - 35	8FN-23815-00	22 - 13	8CR-24301-01	23 - 4	8FA-27114-00	24 - 17	8FM-47424-00	29 - 28
8ES-21410-00	17 - 1	8ES-2196A-01	19 - 68	8FA-23818-02	21 - 12	8FN-24311-00	23 - 14	8JE-27431-00	19 - 85	8GL-47445-00	28 - 62
8ES-21420-00	17 - 2	8FA-2196E-01	19 - 69	8FK-2381B-00	21 - 8	8GS-24311-00	23 - 14	8FN-28100-01	36 - 1	83R-47446-00	29 - 4
8ES-21459-00	12 - 6	8FA-2196F-00	19 - 71	8FA-23821-00	21 - 34	8FN-24311-10	23 - 15	8GS-2815J-E0	9 - 30	8ET-47446-00	27 - 39
8FN-21481-01	17 - 4	8FG-2196M-00	19 - 43	8FN-23826-00	21 - 44	8GS-24311-10	23 - 15	8GS-2815J-J0	9 - 30	8ES-47447-00	28 - 55
8FG-21495-00	17 - 8	8FN-2196T-00	36 - 22	8FN-23828-00	21 - 29	8FA-24335-00	23 - 8	8GS-2815J-S0	9 - 30	8ES-47456-00	27 - 7
8FG-2149C-00	17 - 9	8GS-21970-00	19 - 54	8FS-23829-00	21 - 2	8FA-24491-00	9 - 33	8ET-2815K-00	34 - 9	8AC-47457-00	27 - 10
8FN-21557-00	19 - 90	8FA-21972-01	19 - 70	8FN-23831-00	21 - 48	8H5-24560-00	23 - 6	8ET-2815K-10	34 - 10	8AX-47458-00	27 - 12
8GU-21641-00	48 - 9	8FN-21973-00	36 - 7	8FA-23843-00	21 - 28	8FG-24610-01	23 - 2	4B5-2815K-20	35 - 2	8K2-47458-01	27 - 8
8ES-21745-00	18 - 14	8FR-2197E-00	19 - 83	8CR-23845-10	21 - 31	8HV-24641-00	23 - 3	8HF-2817S-00	37 - 35	8JD-47465-00	28 - 2
8ES-2174N-00	18 - 16	8ES-2197H-01	33 - 27		21 - 49	8FN-2470F-10	24 - 2	8GS-2817S-E0	37 - 35	8ES-47467-00	28 - 66

NUMERICAL INDEX

PART NO.	REF. NO.	PART NO.	REF. NO.	PART NO.	REF. NO.	PART NO.	REF. NO.	PART NO.	REF. NO.	PART NO.	REF. NO.
8V0-47468-00	29 - 27	8EK-47715-00	30 - 8	8JE-77543-00	37 - 14	1AE-82151-00	46 - 8	5TG-84163-00	36 - 26	90101-10357	31 - 9
83R-47469-10	27 - 49	8FN-77108-00	33 - 11	8JE-77544-00	37 - 15	5JJ-82151-10	45 - 11	8DN-84310-01	42 - 1	90102-10044	21 - 45
8JE-47473-00	28 - 63	8FN-77109-00	33 - 10	8FN-77551-00	37 - 20	5JJ-82151-20	45 - 9	8G9-84314-00	42 - 2		21 - 53
8JE-47473-10	28 - 63	8FN-77111-00-P6	33 - 1	8FN-77552-00	37 - 23	5JJ-82151-30	45 - 10	8A5-84331-00	42 - 6	90105-05644	15 - 7
8JE-47474-00	28 - 64	8FN-77118-00	33 - 18	8FA-77561-00	33 - 37	5JJ-82151-50	45 - 12	8A5-84332-00	42 - 7		15 - 15
8JE-47474-10	28 - 64	8JE-7711L-00	34 - 2	8FA-77562-00	33 - 38		48 - 5	8FN-84359-00	42 - 10		51 - 6
8JD-47475-00	28 - 61	8JE-7711M-00	34 - 3	80M-77591-00	37 - 29	8JE-82305-00	45 - 1	8DS-84366-00	33 - 7		52 - 4
8AC-47478-10	29 - 8	8FN-77130-00	33 - 8	84R-77592-00	37 - 33	8ES-82310-00	45 - 5	8K4-84374-00	42 - 5	90105-06026	1 - 6
8DM-47479-00	27 - 62	8FN-77131-00	38 - 4	83R-77595-00	37 - 27	8FN-82509-00	6 - 90	8DN-84397-01	42 - 3	90105-06066	7 - 3
8JE-47480-00	28 - 35	8FN-77132-00	38 - 5	8FN-77711-00	38 - 1	8JE-82509-00	48 - 4	8FN-84710-00	43 - 1	90105-060A6	23 - 12
8JE-47480-10	28 - 35	8FN-77133-00	36 - 14	8GS-77735-00	38 - 6	8HV-82510-00	45 - 20	1A2-84714-41	43 - 2		31 - 17
8JE-47480-20	28 - 35	8FN-77134-00	33 - 9	8DM-77761-E0	34 - 6	8GL-82526-09	44 - 9	8FN-84717-00	43 - 6		31 - 71
8JE-47481-00	28 - 20	8FA-77135-00	33 - 25	8FN-77761-E0	34 - 7	8CR-82530-01	25 - 25	8FP-85075-00	18 - 8	90105-06123	12 - 15
8JE-47481-10	28 - 20	8FN-77140-00	33 - 21	8BY-77761-J0	34 - 6	5LP-82540-01	31 - 40	8GM-85110-00	47 - 1	90105-06185	45 - 7
8JE-47481-20	28 - 20	8JE-77141-00	34 - 1	8FN-77761-J0	34 - 7	8FP-8254B-00	46 - 12		47 - 5	90105-06734	16 - 8
83R-47485-02	28 - 11	89A-77159-00	24 - 3	8FN-77761-R1	34 - 7	8FP-82558-00	44 - 6	3Y6-85130-02	47 - 3	90105-07004	4 - 3
	28 - 70		33 - 20	8GS-77761-R1	34 - 6	8JE-82590-00	45 - 8		47 - 5	90105-08072	19 - 8
8JD-47486-00	28 - 7	8JE-7715A-00	34 - 4	8DM-77761-S0	34 - 6	8ES-82720-02	44 - 1	8FA-85720-01	18 - 7		21 - 9
8JD-47487-00	28 - 29	8FN-77161-00	33 - 15	8FN-77761-S0	34 - 7	8ET-82917-00	36 - 17	8GS-85752-00	23 - 9	90105-08153	31 - 73
8JD-47487-10	28 - 51	8FN-77162-00	33 - 16	86D-77762-00	36 - 10	8CN-82917-01	6 - 89	5YP-85790-00	6 - 29	90105-081A7	22 - 7
8JE-47488-00	28 - 67	8FA-77167-10	33 - 14	8BD-77762-00	36 - 10	8FA-82970-01	44 - 7	8ES-85885-01	10 - 45	90105-08483	29 - 11
8HF-47494-00	28 - 38	8FA-77171-00	38 - 8	8BD-77762-21	36 - 10	3MX-83371-11	48 - 2	8ES-85991-00	45 - 2	90105-08552	21 - 17
8JD-47495-00	28 - 16	8FR-77185-00	33 - 39	8AC-77762-R1	36 - 10	8GL-83383-00	45 - 24	8GL-86284-09	44 - 2	90105-10027	28 - 43
8GC-47496-00	27 - 25	8FN-77210-00	35 - 5	8GS-77763-E0	34 - 8	8JE-833A0-00	48 - 1	8JE-F3711-00	20 - 1	90105-10096	25 - 17
8JD-47496-00	28 - 57	82H-77223-00	35 - 6	8GS-77763-J0	34 - 8	8JE-83500-00	41 - 1	8JD-F3731-00	20 - 3	90105-10151	24 - 8
8GS-47511-00	30 - 1	8FN-77251-00	35 - 1	8GS-77763-S0	34 - 8	4XV-83513-00	41 - 9	8HR-F3738-00	20 - 4		24 - 15
83R-47520-10	27 - 48	8FN-77261-00	6 - 61	8ES-81410-01	39 - 1	4WM-83517-00	41 - 2	8HR-F3754-00	20 - 2	90105-10209	28 - 30
	27 - 54	8FN-77262-00	36 - 18	8ES-81450-01	39 - 6	4WM-83517-10	41 - 3	8HR-F3778-00	20 - 5		28 - 52
8JD-47531-00	30 - 2	8FN-77263-00	36 - 19	8ES-81517-01	10 - 55	5PW-8352S-00	41 - 6	8FN-K7210-00	35 - 5	90105-10223	31 - 62
8JD-47532-00	30 - 3	8FN-77264-00	33 - 6	2S3-81801-00	40 - 2	8EK-8353E-01	41 - 4	8CR-W0041-00	25 - 19	90105-10230	20 - 35
8JD-4753A-00	30 - 4	8FN-77271-00	33 - 3	8FA-8181L-00	40 - 5	8EK-83572-01	41 - 5	8FA-W0045-00	25 - 33	90105-10232	20 - 58
8GS-47541-00	31 - 1	8FN-77272-00	33 - 4	2S3-8182G-00	40 - 3	8FA-83614-00	6 - 56	8FU-W0046-01	25 - 10	90105-10237	28 - 13
8GS-47543-10	31 - 32	8FN-77273-00	33 - 5	1D7-81835-00	40 - 6	8GK-83755-11	45 - 21	3JD-W0047-10	25 - 9		28 - 72
8GS-47546-00	31 - 52	8ES-77276-00	33 - 30	8ES-8183G-00	40 - 12	5FU-83790-20	10 - 53	8CR-W0048-00	25 - 13	90105-10329	28 - 9
8AC-47550-00	27 - 21	8GS-77277-00	33 - 31	8ES-81846-01	40 - 9	1UY-83909-00	44 - 13	8FU-W0057-00	25 - 8	90105-10392	20 - 59
8CR-47550-10	27 - 58	8FA-77311-02	36 - 2	5PX-81861-00	40 - 8	8CR-83912-00	25 - 24	8GS-W1246-01	6 - 71	90105-10410	20 - 6
8HF-47550-10	27 - 59	8CR-77319-00	36 - 8	8GL-81890-00	40 - 1	8DN-83912-00	25 - 24	8ES-W176G-12	51 - 1	90105-10549	21 - 15
8EK-47551-00	45 - 23	8CR-77338-00	36 - 3	3D7-81940-00	46 - 7	8FA-83922-00	25 - 39	8FA-W176H-10	52 - 1	90105-12017	21 - 40
8GS-47554-01	31 - 31	8FA-77373-00	36 - 5	5DM-81950-00	45 - 18	437-83936-01	48 - 7	8JE-W2195-00	19 - 40	90105-12032	2 - 13
8GS-47558-00	31 - 8	8CR-77384-01	6 - 44	8DM-81950-11	45 - 19	5GH-83941-00	44 - 10	8CR-W2585-00	25 - 20	90105-12078	20 - 48
8GS-47564-00	31 - 80		36 - 6	5JW-81960-00	45 - 6	3L4-83943-00	44 - 12	3GM-W2585-21	25 - 20	90105-14003	31 - 89
8GS-47571-00	31 - 75	8FN-77390-00	36 - 13	4SH-82100-22	46 - 1	8FA-83943-00	44 - 11	8EN-W2587-00	25 - 18	90105-14766	16 - 25
8JD-47578-00	36 - 11	8FN-77511-20	37 - 1	8FA-82103-00	10 - 54	85G-83956-00	44 - 3	8EN-W2587-10	25 - 18	90109-06015	8 - 5
8JE-47587-00	31 - 58	8FN-77512-00	19 - 75	8FN-82115-00	46 - 10	8FA-83973-01	44 - 8	8CR-W2628-10	33 - 42		13 - 10
8CW-47591-00	31 - 16	8FN-77523-00	37 - 3	8FN-82116-00	46 - 13	8FR-83976-02	48 - 3	8FM-W4741-10	29 - 25	90109-06031	8 - 7
8GS-47591-00	31 - 19	8FN-77524-00	37 - 4	8FA-82122-00	46 - 2	8CR-8398X-00	25 - 26	8CR-W7726-00	33 - 2		11 - 5
8ES-47613-00	31 - 47	8FN-77541-00	37 - 7	8FA-82129-00	46 - 5	8R6-8399F-00	44 - 4	8FN-Y291E-02	19 - 5	90109-06081	8 - 6
8FN-47631-00	16 - 15	8FN-77542-00	37 - 11	8DM-82131-10	46 - 6	8FN-8399N-00	42 - 9	90101-06047	31 - 30	90109-06185	12 - 12

NUMERICAL INDEX

PART NO.	REF. NO.	PART NO.	REF. NO.	PART NO.	REF. NO.	PART NO.	REF. NO.	PART NO.	REF. NO.	PART NO.	REF. NO.
90109-06187	4 - 10	90170-10186	21 - 33	90201-10118	25 - 16	90261-06019	49 - 2	90280-03045	2 - 12	90387-06033	43 - 4
90109-06220	33 - 35		21 - 52		25 - 31	90261-06028	49 - 2	90282-07002	25 - 2	90387-06043	25 - 40
90109-06272	37 - 21	90176-10033	19 - 25	90201-10126	28 - 12	90261-06033	15 - 28	90338-20004	11 - 29	90387-06058	25 - 34
90109-063F1	37 - 22	90179-05523	35 - 8	90201-10136	28 - 46		49 - 2	90338-20007	11 - 30	90387-06059	32 - 12
90109-066F0	1 - 16	90179-06520	37 - 6	90201-103U7	28 - 48	90261-06034	49 - 2	90338-28242	37 - 25	90387-065V0	9 - 35
90109-10030	27 - 24	90179-08327	2 - 4	90201-10591	2 - 35	90266-06001	49 - 2	90338-30256	33 - 29	90387-06681	33 - 23
	28 - 6	90179-08655	16 - 10	90201-106F2	20 - 62	90266-06002	49 - 2	90340-14117	13 - 4	90387-08071	11 - 21
90109-10056	20 - 38	90179-10679	31 - 35	90201-10742	21 - 47	90267-47186	24 - 14	90340-27129	1 - 4	90387-081M9	25 - 43
90110-05034	39 - 3	90179-12004	17 - 7	90201-12032	20 - 56		36 - 34		12 - 2	90387-082J1	29 - 10
90110-06043	36 - 28	90183-05024	42 - 8	90201-120T5	17 - 10		48 - 11	90340-32080	13 - 2		29 - 15
90110-06164	8 - 11	90183-05068	33 - 12	90201-12161	25 - 37	90267-47187	19 - 74	90380-16109	29 - 24	90387-10008	21 - 46
90110-06168	14 - 5		36 - 15	90201-121H0	2 - 14	90267-47195	11 - 8	90380-28237	15 - 18	90387-10022	28 - 8
90110-06187	39 - 5	90183-06053	33 - 32	90201-121U3	21 - 43		19 - 13		52 - 6	90387-10023	28 - 37
90110-06223	39 - 2	90183-060A0	11 - 11	90201-12317	29 - 6		19 - 47	90381-14001	21 - 39	90387-10024	28 - 32
90110-06234	13 - 11		11 - 28		32 - 7		19 - 82	90381-15001	19 - 3	90387-10029	20 - 9
90110-08104	20 - 26	90183-06100	33 - 33	90201-125A3	17 - 11		19 - 89		19 - 6	90387-10099	20 - 37
90111-05020	36 - 25	90183-08065	33 - 13	90201-12790	6 - 30		36 - 9	90381-15N50	20 - 14	90387-10103	28 - 23
90111-06042	25 - 35	90185-10019	29 - 19	90201-141A3	16 - 24	90267-48010	36 - 4		20 - 19	90387-1012H	20 - 8
90111-08054	25 - 44	90185-12058	29 - 7	90201-16245	31 - 70	90267-48014	26 - 5		20 - 30	90387-1014Y	29 - 22
90113-05053	15 - 6	90201-047R8	27 - 6	90201-19008	28 - 68	90267-48016	19 - 14		20 - 33	90387-101A1	28 - 40
90113-06039	27 - 20	90201-05036	33 - 40	90201-20022	27 - 52		19 - 48	90381-16004	19 - 4	90387-10N59	20 - 61
	27 - 23		48 - 10		27 - 57		19 - 62		19 - 7	90387-12054	20 - 50
90113-06064	30 - 6	90201-05725	41 - 8	90201-222F0	16 - 22	90267-48018	6 - 59	90381-16N51	20 - 43	90387-14019	16 - 23
	31 - 64	90201-06037	16 - 9	90201-225A4	16 - 22		19 - 45		20 - 46	90387-1815A	29 - 20
90119-06179	11 - 24	90201-06042	32 - 15	90201-252F1	25 - 6		19 - 73	90381-18N51	20 - 15	90387-19002	28 - 14
90119-08112	11 - 22	90201-06050	25 - 42	90201-25526	16 - 21		33 - 19		20 - 20	90387-20022	27 - 51
90119-09004	12 - 9	90201-06072	33 - 46	90201-25527	25 - 5	90267-48023	19 - 21	90381-25115	20 - 13		27 - 56
90119-10004	1 - 10	90201-06081	28 - 18	90201-266P2	31 - 51		19 - 49		20 - 18	90387-20023	27 - 55
90149-05129	6 - 83		28 - 59	90201-30013	14 - 6	90267-48026	19 - 37	90381-28108	28 - 65	90387-2008G	31 - 60
90149-05299	35 - 7	90201-06099	31 - 29	90201-320S3	31 - 61	90267-48028	19 - 38	90383-17001	21 - 36	90387-22005	31 - 49
90149-06148	6 - 37	90201-061H1	16 - 9	90202-08204	15 - 24	90267-48029	19 - 39	90383-23002	28 - 3	90387-25011	25 - 4
90149-06263	38 - 2	90201-08020	21 - 10		51 - 15	90267-48083	19 - 72	90384-16N51	20 - 23	90387-25018	31 - 63
90149-06330	23 - 21	90201-08053	23 - 29	90202-09227	15 - 21	90267-48086	37 - 28	90384-19001	32 - 9	90387-2508C	31 - 12
90149-08034	16 - 20	90201-08060	32 - 21		51 - 17	90267-48095	19 - 81	90384-38243	16 - 6	90387-26007	31 - 56
90150-05040	49 - 10	90201-08075	23 - 30		52 - 7	90267-48176	19 - 18		16 - 12	90387-30005	31 - 53
	49 - 15	90201-08326	22 - 8	90202-22238	29 - 21		19 - 51		49 - 12	90401-10015	25 - 15
90150-06015	22 - 15	90201-08403	25 - 45	90208-26002	31 - 55	90267-48177	19 - 19	90384-41242	15 - 4		25 - 30
90151-05048	32 - 18	90201-08649	29 - 9	90209-15N50	20 - 41		19 - 22		52 - 2	90401-10045	20 - 51
90151-06010	27 - 3		29 - 16		20 - 55		19 - 50	90386-08002	15 - 26	90430-06192	8 - 8
	29 - 29	90201-08759	21 - 57	90210-06006	19 - 61	90267-48182	6 - 39	90386-09001	15 - 23	90430-08119	1 - 8
90151-06024	2 - 27	90201-08784	6 - 86		31 - 72	90267-48194	27 - 5	90386-16001	28 - 39	90430-08204	18 - 6
90154-06009	33 - 34	90201-10038	27 - 34	90210-08017	31 - 14	90267-48199	27 - 9	90386-20001	28 - 28	90430-10148	31 - 41
	37 - 24		27 - 44		31 - 74		27 - 13		28 - 50	90430-14043	31 - 90
	38 - 7	90201-10043	28 - 41	90214-10003	27 - 36	90269-05055	6 - 60	90387-0514T	15 - 5	90445-112E0	6 - 34
90154-06062	16 - 4	90201-10052	20 - 40	90214-10007	28 - 71	90269-06006	15 - 27		51 - 5	90445-11M52	9 - 27
90159-05035	45 - 25		20 - 54	90215-10003	2 - 34		49 - 2	90387-0514U	15 - 14	90445-120J6	6 - 50
90159-06011	33 - 36	90201-10061	27 - 28	90249-06002	32 - 13	90269-06046	42 - 4		51 - 11	90445-120J8	6 - 35
90170-08358	31 - 26	90201-10072	28 - 10	90261-06015	49 - 2	90269-09002	19 - 92		52 - 3	90445-26005	28 - 15

NUMERICAL INDEX

PART NO.	REF. NO.	PART NO.	REF. NO.	PART NO.	REF. NO.	PART NO.	REF. NO.	PART NO.	REF. NO.	PART NO.	REF. NO.
90450-28014	6 - 49	90467-11032	23 - 24	90501-582L2	49 - 4	92017-06014	25 - 41	93317-21578	31 - 66	95602-08200	19 - 57
90450-35001	6 - 14	90467-110A2	6 - 3	90501-582L6	49 - 4	92902-08600	37 - 32		31 - 69		20 - 27
	6 - 41		6 - 5	90501-582L7	49 - 4	92902-10600	27 - 63		31 - 82		21 - 18
	6 - 69		6 - 8	90501-583L0	49 - 4	92907-06600	15 - 20		31 - 84		22 - 11
	6 - 78		6 - 12	90501-583L1	49 - 4		51 - 14	93317-33179	31 - 59		29 - 12
90450-38040	6 - 7		6 - 13	90501-583L4	49 - 4	92907-16100	15 - 32	93317-41785	21 - 38		29 - 14
90450-57016	9 - 3		6 - 18	90501-583L5	49 - 4		51 - 19	93410-06053	32 - 14	95602-10200	20 - 7
90450-67003	9 - 25	90467-12053	18 - 10	90501-600A1	15 - 29	92990-08200	11 - 15	93420-26077	5 - 19		20 - 36
90460-15126	6 - 64		18 - 17		49 - 4	93102-10207	5 - 6	93440-39175	31 - 79		20 - 39
	6 - 80	90467-17089	6 - 20	90501-600A4	49 - 4	93102-15212	31 - 21	93450-19095	2 - 9		20 - 53
	13 - 8		6 - 22	90501-600A5	49 - 4	93102-30012	31 - 4		2 - 11		20 - 60
90462-08225	13 - 8		6 - 23	90501-601L7	49 - 4	93102-35010	31 - 5	93450-32152	2 - 31		21 - 16
90462-10022	22 - 12		18 - 19	90501-601L8	49 - 4		31 - 34	93503-08007	31 - 87		27 - 29
90464-08126	46 - 11	90467-20085	18 - 19	90501-602L3	49 - 4	93102-45008	2 - 19	93604-16092	5 - 10		27 - 37
90464-09015	23 - 25	90467-22080	18 - 20	90501-602L8	49 - 4	93108-37011	28 - 4	93606-20044	31 - 37		27 - 47
90464-11007	22 - 2	90467-22097	7 - 11	90501-602L9	49 - 4	93210-06001	40 - 4	93700-06004	20 - 16		28 - 26
90464-12045	45 - 15		7 - 12	90501-603L2	49 - 4	93210-14369	13 - 5		20 - 21		28 - 34
90464-13073	26 - 3		7 - 14	90501-603L3	49 - 4	93210-14579	7 - 7		20 - 31		28 - 44
	45 - 14	90467-28046	6 - 66	90501-624L8	49 - 4	93210-16629	7 - 16		20 - 34		31 - 44
90464-13077	45 - 16	90467-28144	6 - 63	90508-500B1	49 - 6	93210-18322	7 - 6		20 - 44	95602-12200	20 - 49
90464-13194	9 - 9		6 - 70	90508-536A9	49 - 6	93210-19026	18 - 3		20 - 47	95602-14200	27 - 53
90464-14M55	22 - 3	90467-310A0	6 - 67	90508-556A2	49 - 6	93210-19123	1 - 15		20 - 52		27 - 61
90464-15195	6 - 79	90468-04092	23 - 5	90508-556A7	49 - 6	93210-24235	40 - 10	94580-25064	7 - 18	95607-05200	51 - 7
	45 - 13	90468-08104	18 - 9	90508-60007	49 - 6	93210-24709	12 - 4	94591-59140	4 - 4		52 - 5
90464-16010	23 - 26		18 - 15	90508-60012	49 - 6	93210-25071	31 - 11	94701-00411	1 - 9	95607-08200	19 - 9
90464-20181	6 - 55	90468-12006	21 - 19	90508-60016	49 - 6	93210-25642	16 - 19	94703-00411	1 - 9	95607-10200	19 - 11
90464-25004	43 - 7	90480-16278	19 - 94	90508-60018	16 - 13	93210-26006	6 - 15	94890-09068	31 - 57	95607-12200	32 - 4
90464-35132	45 - 17	90480-18007	43 - 3	90793-26123	46 - 1	93210-32172	13 - 3		50 - 2	95617-08630	16 - 7
90465-06M28	6 - 31	90501-050A0	31 - 67	91312-06016	6 - 16	93210-41041	23 - 10	94890-09070	50 - 2		49 - 13
90465-08368	19 - 33	90501-066J5	31 - 78	91312-06020	9 - 2	93304-20511	31 - 3	95022-06008	46 - 9	95702-05300	33 - 41
90465-10038	13 - 9	90501-08668	23 - 17	91312-06025	5 - 16	93306-00006	5 - 5	95022-06020	4 - 7	95702-05500	45 - 26
90465-10048	6 - 38	90501-10353	31 - 88	91312-06040	5 - 15		5 - 18		6 - 28		47 - 2
90465-13152	48 - 8	90501-120A0	25 - 36	91312-06065	1 - 19	93306-00208	31 - 20	95022-06085	9 - 36	95702-06300	28 - 19
90467-08092	9 - 11	90501-130A0	32 - 11	91316-06022	25 - 29	93306-00444	27 - 60	95022-08012	1 - 7		28 - 60
	9 - 13	90501-407E4	29 - 5	91317-06016	18 - 4	93306-00507	27 - 19	95022-08020	11 - 6	95702-06500	6 - 82
90467-09026	9 - 14	90501-550A2	49 - 4	91401-20020	20 - 10		27 - 32	95302-06700	40 - 7		9 - 34
	23 - 19	90501-550A3	49 - 4	91609-30008	29 - 23		27 - 42		40 - 11		24 - 7
	23 - 27	90501-550A5	49 - 4	91609-50032	15 - 12	93306-00711	31 - 38	95307-08700	31 - 27		37 - 19
90467-10041	9 - 28	90501-550A6	49 - 4		51 - 16	93306-01003	2 - 20	95307-10600	31 - 10		43 - 5
90467-100A1	1 - 21	90501-551L3	49 - 4		1 - 5	93306-20212	32 - 2	95307-10700	21 - 32	95702-08300	23 - 28
	13 - 13	90501-551L9	49 - 4	91808-16023	1 - 5	93306-20511	31 - 33		21 - 51		45 - 22
90467-11019	13 - 14	90501-552L5	49 - 4	91808-22019	7 - 9	93306-20589	30 - 5	95312-08600	21 - 25	95702-08500	6 - 85
90467-11028	9 - 5	90501-580A1	49 - 4	91A20-05130	23 - 18	93306-20601	31 - 2	95602-05200	15 - 8		37 - 10
	9 - 7	90501-580A2	49 - 4	92012-06012	19 - 84	93306-30323	2 - 24		15 - 16		37 - 12
	9 - 8	90501-580A3	49 - 4	92012-08025	11 - 14	93306-30579	16 - 16	95602-06200	32 - 16	95702-10300	21 - 54
90467-11032	6 - 36	90501-580A4	49 - 4	92014-06020	21 - 3	93306-30721	2 - 17		33 - 24		27 - 64
	6 - 51	90501-581L5	49 - 4			93310-42239	2 - 28		33 - 45	95702-10500	21 - 55
	23 - 7	90501-581L6	49 - 4			93311-32685	31 - 48	95602-08200	18 - 12	95702-05300	25 - 27
	23 - 16	90501-582L1	49 - 4								

NUMERICAL INDEX

PART NO.	REF. NO.	PART NO.	REF. NO.	PART NO.	REF. NO.	PART NO.	REF. NO.	PART NO.	REF. NO.	PART NO.	REF. NO.
95707-05500	47 - 4 47 - 6	95822-06020	18 - 21 37 - 5	99009-52500	31 - 7 31 - 36						
95707-06500	19 - 87	95822-06025	31 - 46	99009-62500	16 - 17						
95712-08300	37 - 31	95822-08014	24 - 19		31 - 6						
95802-06014	37 - 18		32 - 20	99246-00200	34 - 11						
95802-06016	33 - 22	95822-08016	6 - 84	99530-08012	5 - 14						
95807-06012	19 - 86		19 - 79		8 - 3						
95807-08012	18 - 5		37 - 9		13 - 7						
95812-06008	11 - 10 11 - 25	95822-08020	46 - 4 19 - 80	99530-10014	12 - 7						
	11 - 27		22 - 9	99530-10114	12 - 8						
95812-06012	7 - 20 32 - 24		32 - 22 37 - 2								
95812-06014	6 - 10	95822-08025	37 - 30								
95812-06016	6 - 54	95822-08030	31 - 42								
	11 - 12	95822-10016	19 - 58								
	18 - 11	95822-10020	37 - 8								
	19 - 60		37 - 17								
95812-06020	2 - 21	95822-10025	30 - 9								
95812-06040	7 - 8	95822-10045	31 - 43								
95812-06055	12 - 13	95822-10090	31 - 45								
95812-06080	12 - 14	95827-08016	32 - 6								
95812-08014	36 - 31		37 - 16								
	36 - 35	95827-08025	37 - 34								
95812-08016	37 - 13	97002-06025	28 - 17								
95812-08020	11 - 18		28 - 58								
95812-08030	17 - 3	97002-08014	31 - 13								
	40 - 13	97012-10025	2 - 33								
95812-08035	29 - 13	97017-06030	15 - 19								
95812-08055	12 - 10		51 - 13								
95812-08070	12 - 11	97607-05112	44 - 14								
95812-10030	29 - 18	97702-50016	33 - 17								
95812-10045	28 - 24		35 - 3								
95812-10050	27 - 27		41 - 7								
	28 - 33	97702-50020	35 - 4								
95812-10070	28 - 25	98502-04014	10 - 23								
95812-10080	27 - 35	98502-05016	44 - 15								
	27 - 45	98502-06016	5 - 8								
95812-10090	28 - 42	98706-04012	25 - 22								
95817-12100	17 - 5	98902-05008	23 - 11								
95817-12200	17 - 6	99001-04600	44 - 5								
95822-06010	45 - 4	99002-08600	5 - 11								
95822-06012	6 - 53	99009-14400	28 - 56								
	6 - 81	99009-24400	25 - 3								
	19 - 76	99009-25400	16 - 18								
95822-06016	9 - 38	99009-26400	31 - 50								
	45 - 3	99009-35400	27 - 40								
	48 - 6	99009-35500	32 - 3								